

Installation, Operation & Maintenance Manual

Models 075 and 150 Coro-Flo® Pumps

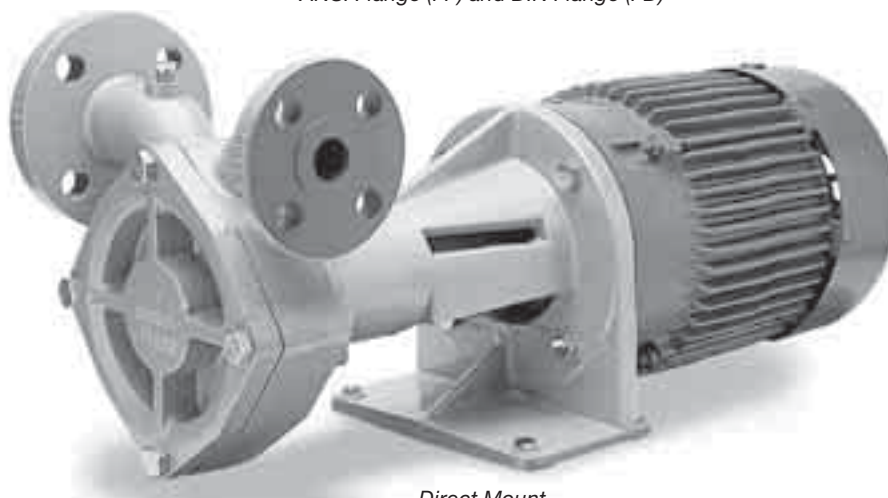

Frame Mount
ANSI Flange (FF) and DIN Flange (FD)



Direct Mount
ANSI Flange (DLF) and DIN Flange (DLD)

Warning: (1) Periodic inspection and maintenance of Corken products is essential. (2) Inspection, maintenance and installation of Corken products must be made only by experienced, trained and qualified personnel. (3) Maintenance, use and installation of Corken products must comply with Corken instructions, applicable laws and safety standards (such as NFPA Pamphlet 58 for LP-Gas and ANSI K61. 1-1972 for Anhydrous Ammonia). (4) Transfer of toxic, dangerous, flammable or explosive substances using Corken products is at user's risk and equipment should be operated only by qualified personnel according to applicable laws and safety standards.

Solutions beyond products...

 **CORKEN**®
IBEX

Warning

Install, use and maintain this equipment according to Corken, Inc. instructions and all applicable federal, state, local laws and codes, and NFPA Pamphlet 58 for LP-Gas or ANSI K61.1-1989 for Anhydrous Ammonia. Periodic inspection and maintenance is essential.

Corken One Year Limited Warranty

Corken, Inc. warrants that its products will be free from defects in material and workmanship for a period of 12 months following date of purchase from Corken. Corken products which fail within the warranty period due to defects in material or workmanship will be repaired or replaced at Corken's option, when returned freight prepaid to: Corken, Inc., 3805 N.W. 36th Street, Oklahoma City, Oklahoma 73112.

Parts subject to wear or abuse, such as mechanical seals, blades, piston rings, valves, and packing, and other parts showing signs of abuse are not covered by this limited warranty. Also, equipment, parts and accessories not manufactured by Corken but furnished with Corken products are not covered by this limited warranty and purchaser must look to the original manufacturer's warranty, if any. This limited warranty is void if the Corken product has been altered or repaired without the consent of Corken.

ALL IMPLIED WARRANTIES, INCLUDING ANY IMPLIED WARRANTY OF MERCHANTABILITY OR FITNESS FOR A PARTICULAR PURPOSE, ARE EXPRESSLY NEGATED TO THE EXTENT PERMITTED BY LAW AND SHALL IN NO EVENT EXTEND BEYOND THE EXPRESSED WARRANTY PERIOD.

CORKEN DISCLAIMS ANY LIABILITY FOR CONSEQUENTIAL DAMAGES DUE TO BREACH OF ANY WRITTEN OR IMPLIED WARRANTY ON CORKEN PRODUCTS. Transfer of toxic, dangerous, flammable or explosive substances using Corken products is at the user's risk. Such substances should be handled by **experienced, trained personnel in compliance with governmental and industrial safety standards.**

Important notes relating to the European Union (EU) Machinery Directive

Pumps delivered without electric motors are not considered as machines in the EU Machinery Directive. These pumps will be delivered with a Declaration of Incorporation. The fabricator of the machinery must assure and declare full compliance with this Directive before the machine in which the pump will be incorporated, or of which it is a part, is put into service.

Contacting The Factory

For your convenience, the model number and serial number are given on the compressor nameplate. Space is provided below for you to keep a written record of this information.

Always include the model number and serial number when ordering parts.

Model No. _____

Serial No. _____

Date Purchased _____

Date Installed _____

Purchased From _____

Installed By _____

Table of Contents

Principles of the Coro-Flo® Pump	4
Exclusive Features of Your Coro-Flo® Pump	4
Installation of Your Coro-Flo® Pump	5
Inlet Piping Should Include the Following	5
Outlet Piping Should Include the Following	5
Bypass System Must Include the Following	5
Design Criteria for Underground Tank Applications.....	6
Pump Foundation for Frame Mounted Models	6
Level Base.....	6
Coupling Alignment for Frame Mounted Models	6
Driver Installation	6
Wire Sizing Chart	7
Operation of Your Coro-Flo® Pump.....	7
Filling New Cylinders and Tanks.....	8
Preventative Maintenance Program for Your Coro-Flo® Pump	8
Repair and Service on Your Coro-Flo® Pump.....	9
Seal Replacement Instructions.....	10
Appendix A:	
Model Number and Mounting Identification Codes for 075-Model Coro-Flo® Pumps.....	15
Model Number and Mounting Identification Codes for 150-Model Coro-Flo® Pumps.....	16
Appendix B: Material and Operating Specifications for 075- and 150-Model Coro-Flo® Pumps	17
Appendix C:	
Performance Curves for 075-Model Coro-Flo® Pumps.....	18
Performance Curves for 150-Model Coro-Flo® Pumps.....	19
Appendix D: Outline Dimensions for 075- and 150-Model Coro-Flo® Pumps	20
Appendix E: Parts Details for 075- and 150-Model Coro-Flo® Pumps	22
Appendix F: Installation Tips for 075- and 150-Model Coro-Flo® Pumps.....	24
Appendix G: Troubleshooting Guide	31
Appendix H: Extended Storage Procedures	33

Principles of the Coro-Flo® Pump

The Corken Coro-Flo® pump is a special type of pump known as a turbine or regenerative pump. The liquid flows into the inlet nozzle and into the passageway on each side of an impeller (the rotating element) and is recirculated constantly between the vanes or teeth of the impeller and this passageway as the impeller rotates. The fluid makes a complete revolution in the pump case and is diverted through the outlet flange. The horsepower required to drive the pump increases as the differential pressure increases, but the capacity decreases at the same time. Differential pressure is the difference between the pressure at the inlet of the pump and at the outlet of the pump.

The impeller is the only moving part and has no contact with the casing. Consequently, practically no wear occurs to the impeller, even when pumping volatile liquids such as LP-gas or ammonia which have little lubricating qualities.

Exclusive Features of Your Coro-Flo® Pump

The pumping of volatile liquids is one of the most difficult of all pumping applications. Unlike other pumping applications, more attention must be given to the design, manufacture, installation and operation of the pump.

In addition to being a pump type especially suited for handling volatile liquids, your Coro-Flo® pump has a number of features which help to make it more easily operated and maintained.

The Coro-Flo® pumps of this series are manufactured to be directly connected to an electric motor (direct mount) or with their own frame for connection by means of a flexible coupling (frame mount).

UNDERWRITERS LABORATORIES, INC. has tested and inspected the Coro-Flo® pumps of this series and has listed them for use in the handling of LP-gas and ammonia fluids. The nameplate on the pump includes the UL registration along with other certifications.

DUCTILE IRON has been used in the manufacture of this pump for parts under pressure.

THE IMPELLER floats on a shaft and may be replaced easily without disturbing the piping or driver by simply removing the cover. No special tools are needed.

THE MECHANICAL SEAL ASSEMBLY may be easily replaced by removing the cover and impeller without disturbing the piping or driver. No special tools are needed.

PRESSURE GAUGE CONNECTIONS, 1/4" FNPT, are provided on the inlet and outlet nozzles.

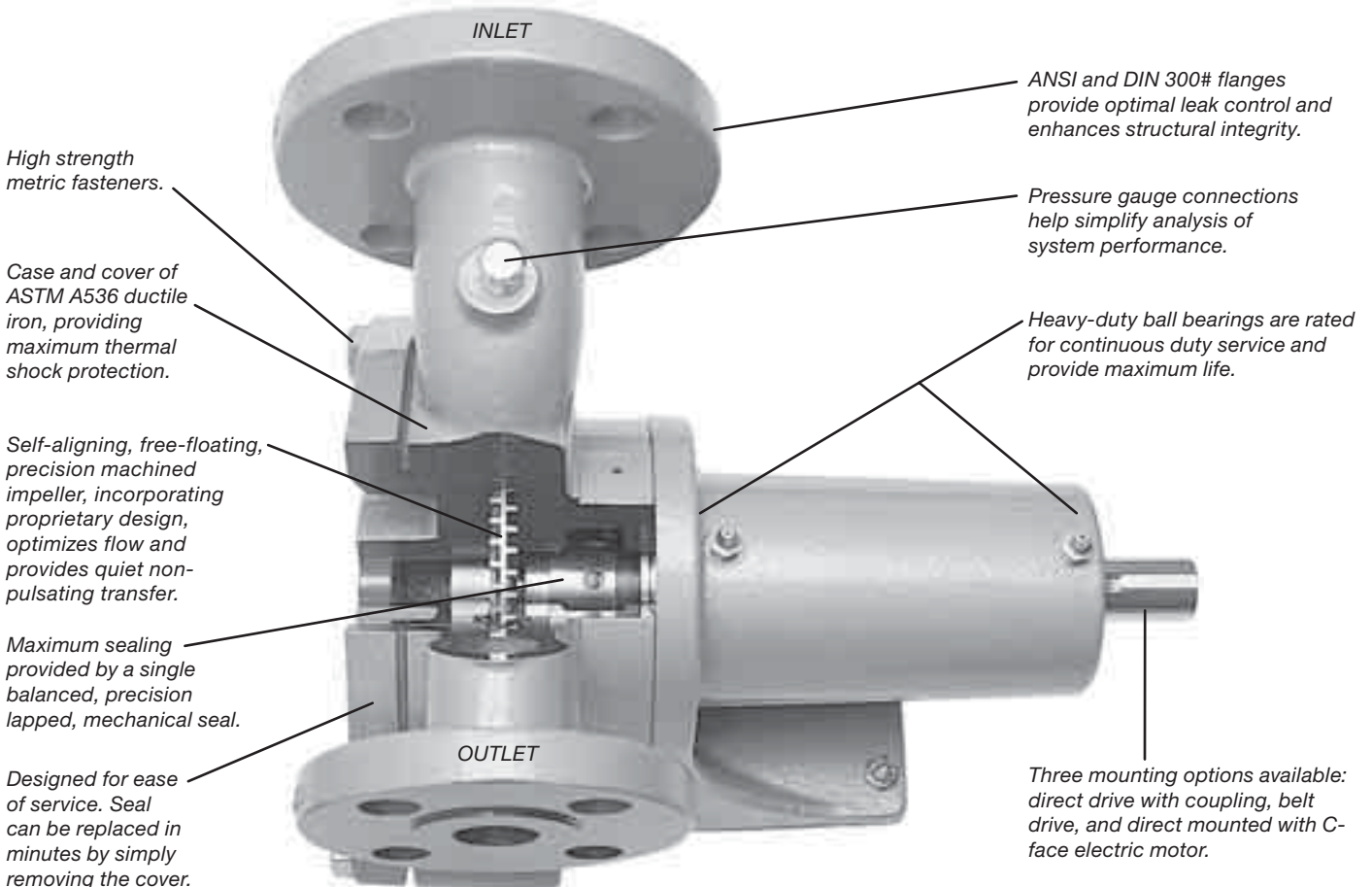

Installation of Your Coro-Flo® Pump

NOTE: Must be installed in a well ventilated area.

THE INSTALLATION OF A CORO-FLO® pump is simple. However, in order for the pump to deliver optimum performance, the principles discussed in this book should be followed. The piping details are furnished to illustrate methods proved by hundreds of installations. Your own needs may require slight variations, but every effort should be made to follow the recommendations identified in this manual.

For more detailed piping recommendations, refer to pages 24–29. For outline dimensional drawings, refer to Appendix D (pages 20 & 21).

For the transfer of flammable liquids like LPG, the pump assembly must be installed according to the applicable local safety and health regulations. The installer and/or the user must take into account the following:

- Potential risk due to local conditions regarding the installation and operation (e.g. poor ventilation and additional risks due to other elements in the vicinity, etc.).
- Qualification of the personnel.
- Type of liquid being transferred.
- Specific safety measures to be applied (e.g. gas detection, automatic shut-off valves, personal protection equipment etc.).

The following table shows the weight of the bare pump for each model. For handling a bare pump, lifting slings should be placed around the inlet and outlet flange neck of the pump. Web slings are preferred over metal slings to minimize damage to the paint.

Model	Shipping Weight	
	lb	kg
Frame Mount	63	28.6
Direct Mount	75	34.0

NO PUMP CAN DISCHARGE MORE LIQUID THAN IT RECEIVES, so the location and the inlet piping must be given careful attention. If the inlet piping is inadequate to supply the demand of the pump, you may expect trouble! The inlet line size should be the same size as the pump suction or next size larger. Pressure loss between the storage tank and the pump should be minimized.

THE PUMP SHOULD BE LOCATED AS CLOSE TO THE STORAGE TANK as possible on above ground tanks. The complete inlet line, including the vertical line from the tank, should not exceed 12 feet (3.6 m) in length. The bottom of the tank should be at least two feet (0.6 m) above the pump inlet nozzle, and four feet (1.2 m) should be considered standard.

The inlet should include the following:

1. The tank excess flow valve (EFV) should have a flow rate of 1-1/2 to 2 times the capacity of the pump. Do not use an EFV without knowing its flow capacity.
2. Pressure gauge at pump suction nozzle.
3. The tank shutoff valve should be a full port ball valve or an internal valve.
4. A strainer of the “Y” type with a 20 mesh screen should be on the inlet line of the pump.
5. A flexible connection should be used on the pump inlet or outlet to accommodate piping strains.
6. An eccentric swage should be used at the pump inlet nozzle to change line size (flat side up).
7. The inlet line must be level or slope downward to the pump.

The outlet piping should include the following:

1. A pressure gauge should be installed in the opening provided on the outlet nozzle or in the outlet piping near the pump. This pressure gauge will tell you the complete story of the operation inside your pump. Be sure you have one installed.
2. A hydrostatic relief valve must be installed in the outlet piping.
3. If the outlet piping exceeds 50 feet (15.2 m) in length, a check valve should be installed near the pump outlet.

The bypass system must include the following:

1. The pump bypass system must be installed. Without this system, the pump has little chance of performing.
2. A CORKEN B166 BYPASS VALVE (a special valve to vent the pump of vapors and to act as a differential relief valve) is ideal.
3. The bypass line should rise uninterrupted to an opening in the vapor section of the storage tank. The tank fitting should be either an excess flow valve or a vapor return valve; it should never be a filler valve or a back check valve.
4. To meet Underwriters Laboratories (UL) specifications, an external bypass valve must be connected in the piping between the pump discharge nozzle and the supply tank for pump recirculation. When bypassing the full output of the pump, the external bypass valve must limit the differential pressure to 125 pounds per square inch.

Design Criteria for Underground Tank Applications:

- Minimize suction frictional losses:
 - Locate pump as close as possible to the tank's liquid outlet connection.
 - Eliminate strainer since the tank itself acts as a sump to collect foreign materials.
 - Use full-port ball valves or low restrictive valves.
 - Use 2-inch (51 millimeter) pipe.
- Minimize the net static suction lift to 14 feet (4.3 m) maximum.
- Use vapor eliminator valves.
- Use back-pressure check valves downstream the pump.
- Limit the capacity of the pump to a maximum of 1.5 percent of the tank's capacity. For example, with a 1,000-gallon (3,785 liter) tank, limit the capacity of the pump to 15 gallons per minute (56.8 liters per minute).

Pump foundation for frame mounted models

The pump assembly must be securely attached to a concrete foundation using all the available holes in the pump assembly footing. The total weight of the concrete foundation should be approximately twice the weight of the pump assembly. The foundation must be level and deep enough to get below the ground frost line in the location. There are many ways to construct a foundation, and the example in figure 1 is only a suggestion.

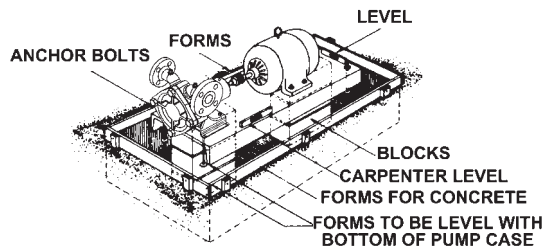

Figure 1

Level base

After the concrete has set, check the pump base for level. Drive metal shims under the base near the anchor bolts as below. Tighten anchor bolts and recheck the base for level (see figure 2).

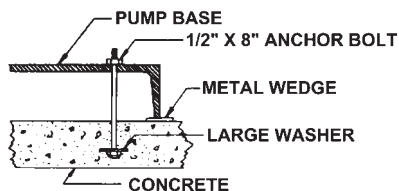

Figure 2

Coupling alignment for frame mount models

The coupling must be properly aligned to give quiet, long-life service to the pump and driver. The pump and driver shafts are carefully aligned at the factory but should always be checked after the pump is installed and before the initial operation.

Place a straight edge across coupling halves, top and side; both positions must line up to be correct.

If misalignment exists, adjust the shims between the pump base and the foundation until exact alignment is accomplished (see figure 3).

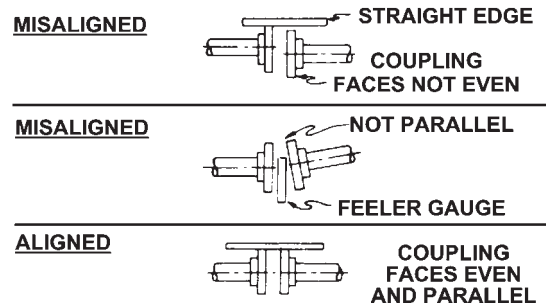

Figure 3

Driver installation

A qualified electrician, in accordance with all the local standards and regulations, must undertake the electrical installation. The wire size chart on page 7, figure 4 indicates the minimum standards for wire sizes.

Improper motor wiring may cause you to experience expensive motor difficulties from low voltage. If you suspect you have low voltage, call your power company. Wiring your motor for the voltage you have available is important. Be sure your motor is connected to the proper voltage. Connecting to improper voltage will completely destroy your motor.

With explosion-proof motor applications in humid climates, the normal breathing and alternating temperatures of the motor (warm during operation and cold when stopped) will often cause moist air to be drawn into the motor housing. This moist air will condense and may eventually add enough free water to the inside of the motor to cause it to fail. To prevent this, make a practice of running the motor and pump at least once a week on a dry day for an hour or so (pump through the bypass system). This allows the motor to heat and vaporize the condensed moisture. No motor manufacturer will guarantee an explosion-proof or totally enclosed motor against damage from moisture.

ENGINE DRIVERS require special consideration; the manufacturer's instructions must be followed. When the Coro-Flo® pump is equipped with an engine from the factory, the engine speed should normally not exceed 3,600 rpm. Excessive engine speed will overload the engine and cause early failure. The engine loses 3 percent of its power for every 1,000 feet above sea level, so if your installation is at a higher altitude than normal, consult the factory.

Motor				Recommended Wire Size, AWG		
Hp	Motor Phase	Volts	Approximate Full Load Amperes	Length of Run in Feet		
				0–100	to 200	to 300
Pump must rotate clockwise when viewed from the motor. If not, switch any two of the three incoming 3 phase lines.						
3	1	115	34.0	6	4	2
		230	17.0	12	8	8
	3	230	9.6	12	12	12
		460	4.8	12	12	12
5	1	115	56.0	4	1	1/0
		230	28.0	10	6	4
	3	230	15.2	12	12	10
		460	7.6	12	12	12
7-1/2	1	230	40.0	8	6	4
	3	230	22.0	10	10	8
		460	11.0	12	12	12
10	3	230	28	8	6	4
		460	14	12	12	10
15	3	230	42	6	4	4
		460	21	10	10	8
20	3	230	54	6	6	4
		460	27	10	10	10

Figure 4: Wire Size Chart for Wiring Electric Motor¹

¹Each country may use a different form of wire size measurement (AWG, SWG, mm² etc.). The above wiring size chart is based on the United States National Electrical Code (NEC) guidelines for America Wire Gauge (AWG) sizes. These wire sizes and distances are based on nominal supplied voltages. Additional derating is necessary when the voltage is less than that shown. Consult your local standards and regulation for specific wiring requirements.

Operation of Your Coro-Flo® Pump

It is absolutely essential that the operator be fully informed of the pump's recommended operation procedures and safety precautions. See Appendix B & C, pages 17–19 for operating specifications and performance. The operator must be made aware of the specific risks generated by the product handled and be familiar with the purpose and function of all piping, valves, and instrumentation, etc. of the installation.

The following steps should be performed for the initial pumping operation:

1. Close shutoff valve on the end of the delivery hose.
2. Open the storage tank bottom shutoff valve.
3. Open the shutoff valve in the pump bypass system.
4. Check the motor for the proper voltage (see instructions under driver installation).
5. Record pressure gauge readings on suction of pump.
6. Start the pump and circulate liquid through the bypass system.
7. Adjust the B166 bypass valve by turning the adjusting screw counterclockwise until the pump pressure gauge shows nearly the same pressure it did before you started the pump. Screw the adjusting screw clockwise until the pressure gauge indicates the required pressure or until the pump starts to lose discharge pressure—you will know this by the rapid fluctuating of the pointer—then back the adjusting screw out a turn or two until the pressure gauge again indicates a steady pressure. Lock the lock nut and permit the pump to circulate liquid for a half hour or more. If the motor overload protection device stops the motor during this period, this indicates the bypass system valve is set too high and should be readjusted by turning the adjusting screw out until the motor will run for this period.

When properly installed and operated, Coro-Flo® pumps should not exceed a 80 dBA noise level at a distance of one meter (3.281 ft.) from the surface of the pump.

Item to Check	Daily	Monthly	Three Months	Six Months
1. Visual Inspection; leaks, hoses, pipes, etc.	●			
2. Clean Inlet Strainer Screen			●	
3. Inspect Drive Coupling and Guard		●		
4. Lubricate Pump's Bearing ¹			●	
5. Lubricate Motor's Bearing ²				
6. Performance Test				●
7. Re-tighten Bolts				●
8. Inspect Motor Starter Points				●

Figure 5: Preventive Maintenance Chart for Coro-Flo® Pumps

¹If the pump runs continuously, it should be lubricated more frequently.

²Follow the motor manufacturer's recommendations.

Filling New Cylinders and Tanks

All new containers are full of air and since air will not liquefy under reasonable filling pressures, it must be purged. To ensure proper gas supply to burners and carburetors, purging air from new containers is essential.

Some cylinders are difficult to fill because they are equipped with a fill tube that extends down into the liquid portion of the container. If possible, these cylinders should be refitted so the incoming liquid enters the vapor section of the cylinder. If refitting is impossible or impractical, rock the cylinder as it is being filled so that liquid will splash up into the vapor section. This will help keep the cylinder filling pressure down to a reasonable limit. A properly fitted cylinder and filling manifold will permit filling a cylinder at no more than 50 to 60 psi differential pressure. When the pump is new, it is recommended to record the flow rate, discharge pressure and suction pressure.

Preventive Maintenance Program for Coro-Flo® Pumps

Purpose

By following an effective preventive maintenance program, unscheduled downtime can be eliminated. This program should be used by the Operation Manager to get a maximum utilization of manpower and equipment as well as to prevent possible unsafe situations and/or production delays due to equipment breakdown.

Scope

The Preventive Maintenance chart in figure 5 includes the items to be regularly checked and inspected with a recommended time schedule. These are basic maintenance recommendations so each company should develop a comprehensive preventive maintenance

schedule that is tailor-made to their individual operational procedures and requirements.

Maintenance must only be performed by a properly trained and qualified individual that follows all the applicable safety procedures.

Procedures

Every procedure herein recommended must be performed in a safe manner utilizing tools and/or equipment which are free of hazards. Be certain to follow the safety codes of practice set by the authorities having jurisdiction. These are general guidelines and are not intended to cover all the safety aspects that must be considered and followed while performing these procedure.

1. Visual inspection:

This includes checking for leaks, corroded areas, condition of hose, piping and fittings, and any unsafe condition which may hinder the safety of the personnel and/or the facility.

2. Clean inlet strainer screen:

A clogged strainer screen will create too much flow restriction and vapor will be formed causing the pump to cavitate. This reduces the pump's capacity and accelerates the wear of the internal parts.

3. Inspect drive coupling and guard:

Check the coupling alignment and the condition of the coupling's rubber insert for cuts, broken sections and wear.

4. Lubricate pump bearings:

Use only ball bearing grease, applied with a manual lubrication pump or gun. Always clean the grease openings thoroughly before greasing.

5. Lubricate motor bearing:

Follow the recommendations of the electric motor manufacturer for the type of grease to use and the lubrication frequency.

6. Performance test:

- A. While transferring liquid with the pump, check the pressure at the pump's inlet port. The pressure drop in the inlet piping should not be greater than 3 pounds per square inch.
- B. While transferring liquid with the pump, close the discharge valve(s) so the full flow will be directed back to the storage tank through the bypass valve. Then slowly close the valve downstream of the bypass valves. The discharge pressure of the pump should increase to the maximum differential pressure of the pump at no flow conditions (see pages 18 & 19, Appendix C: Performance Curves).
- C. If the maximum differential pressure is not obtained, the pump should be serviced. Visually inspect the pump's impeller (refer to instructions on pages 10–14).

Replace the impeller if damaged, broken, warped or worn.

A uniform wear of the impeller will not be visually detected. If the impeller has no visible damages, it can be re-used. The impeller's wear can be compensated by removing the adjustment shims on the pump's cover. Remove one shim at a time, tighten the pump's cover and assure that the pump's shaft rotates. If the pump is locked, re-install the last shim and make sure the shaft rotates easily. For additional help, refer to Appendix G, page 31 Troubleshooting Guide.

7. Re-tighten all hold down bolts.

8. Inspect motor starter contact points:

This must be performed by an authorized and qualified electrician, based on the electric motor manufacturer's guidelines.

9. See Appendix H, page 33 for extended storage procedures.

Repair and Service on Your Coro-Flo® Pump

All repairs to the pump must be performed by qualified personnel in a safe manner, utilizing tools and/or equipment that are free of hazards, and follows the applicable safety codes of practice set by the local authorities having jurisdiction. Make sure the system pressure has been relieved before attempting any repair to the pump.

After a long service life, repairs are limited to replacing the impeller or mechanical seal.

The only wearing part influencing the pumping action is the impeller, so we suggest the pump be given an "efficiency" test before any attempt is made to repair it. The trouble may lie in the piping system rather than in the pump. If the pump will still produce as much differential pressure when circulating through the bypass system as it did when new, you can be sure that your problem is in the system and not with the pump. If the pump does not produce as much pressure as it did originally, remove the cover and inspect the impeller. If visual inspection indicates the impeller is in good condition, remove the thin shim gasket and replace the cover. Many times this procedure will adjust for slight impeller wear. If the impeller is badly worn or damaged, it should be replaced. For additional help, refer to Appendix G, page 31, Troubleshooting Guide.

REPLACING THE IMPELLER is a matter of removing the cover and removing the old impeller from the shaft. If the old impeller is tight on the shaft, threaded bolt holes are provided in the impeller to use for pulling. The new impeller must be a good slip fit on the shaft; it should "float" on the shaft, so it may be necessary to lightly sand the shaft. Clean the pump prior to reassembly (refer to pages 10–14).

REPLACING THE MECHANICAL SEAL is simple and replacement parts are immediately available.

The pumps can be configured with various types of seals and O-rings. Selection of the seals and O-ring materials are based on the product that is being transferred. The most compatible seals and O-ring materials must be selected. Consult the factory or distributor for recommendations if the pump is not handling the product for which it was initially purchased. The model code in the identification plate of the pump indicates the materials in the pump. Refer to pages 15–17, Appendix A and B, for the material in your pump.

Seal Replacement Instructions for 075 and 150-Model Coro-Flo® Pumps

Caution

Bleed all pressure from the pump and piping before starting to install your new seal assembly.

Cleanliness

The smallest amount of dirt on your new seal can prevent a proper seal and cause premature failure. Keep all parts, tools and your hands clean while installing the seal. Avoid touching the smooth lapped faces of the carbon rotor or seal seat. For LP-gas, anhydrous ammonia and similar liquids, you are trying to seal a fluid that is 5 to 10 times thinner than water! Your new seal needs every chance it can get, so keep it clean.

Workmanship

Your CORKEN pump is a precision piece of equipment with very close clearances. Treat it as such. Never use excessive force during disassembly or assembly.

DISASSEMBLY:

STEP 1

Cover/head removal: Remove the cover/head screws and pull the cover/head and case O-ring from the case. Older models will have a clearance shim/s as well. *NOTE: This is a close tolerance fit so if the cover/head does not slide out easily, use two flathead screwdrivers to slowly pry the cover/head away from the pump casing.*

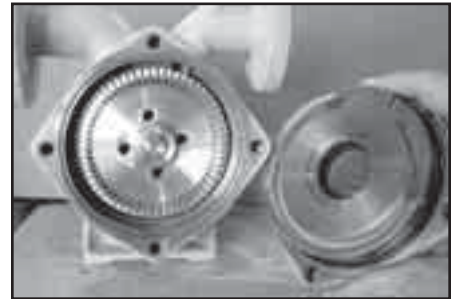
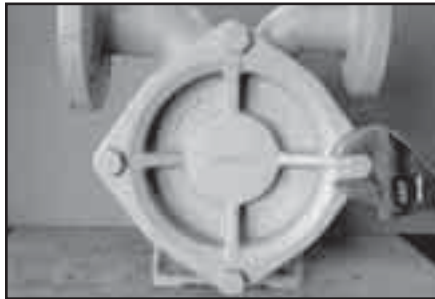

STEP 2

Retainer ring, impeller and impeller key removal: Using a pick or small flathead screwdriver, pry off the retainer ring and remove the impeller. *NOTE: This retainer ring does not apply to older models prior to serial number 226858AG. If the impeller does not slide off the shaft freely, insert two cover/head screws in the threaded holes provided and gently pull outward as shown. NOTE: Being forceful with the removal could warp the impeller or damage the case O-ring groove so use care during this step.* Lastly, remove the impeller key. If the impeller key does not slide off the shaft freely, use side cutters, a pick or a small screwdriver to pry the key up and out of the pump shaft.

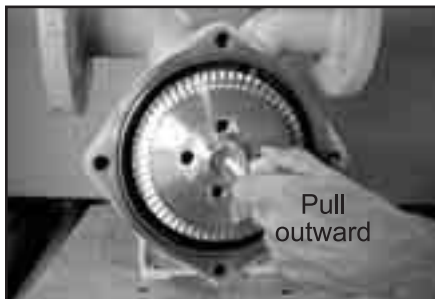
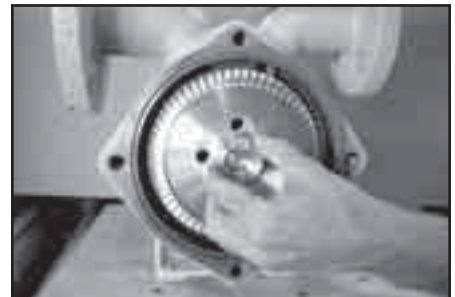
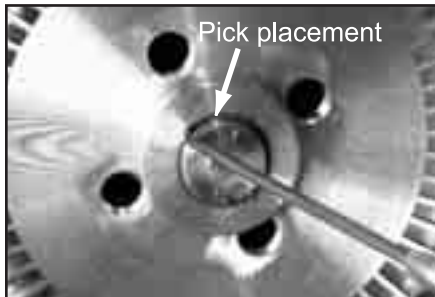

STEP 3

Retainer ring removal: *NOTE: Seal assembly shown is an old design and looks slightly different than our current design listed on the front cover of this booklet.* Using a flathead screwdriver or pick, pry up and pull out on the retainer ring to remove it from the groove and slide off the shaft. *Make sure you do not damage the shaft while removing the retainer ring.*



STEP 4

Seal sub assembly removal: Slide the seal sub assembly (seal and seal sleeve) off the shaft. Next, remove the seal sleeve O-ring from the shaft.

NOTE: Seal assembly shown is an old design and looks slightly different than our current design listed on the front cover of this booklet.



STEP 5

Seal housing removal: Using a 90° pick or hook tool inserted behind the face of the seal housing, slowly pull out around the circumference of the seal housing until you can remove it from the pump casing with your fingers.



STEP 6

Seal housing O-ring removal and bearing inspection: Using a pick, remove the old seal housing O-ring inside the pump casing. Clean the O-ring groove and shaft and remove any burrs around the keyway. The pump shaft bearings should be checked by applying up and down or in and out movement. Since the seal assembly resides on the pump shaft, excess movement may cause a seal leak. In addition, check the bearings for any roughness while turning the shaft. Change the bearings if roughness or movement is present.



STEP 7

Seal seat removal: The seal seat is located inside of the seal housing and must be removed using a pick or small screwdriver by gently prying the seal seat out evenly around the inner circumference of the seal housing assembly. *NOTE: The seal housing assembly should be cleaned before inserting the new seal seat.*



ASSEMBLY

STEP 8

Verify contents of your new 3189-1X_6 seal assembly and clean pump shaft before installation.

NOTE: Install two locator pins into the seal sleeve assembly before proceeding to STEP 9. Refer to the old seal sleeve for proper location of the locator pins.

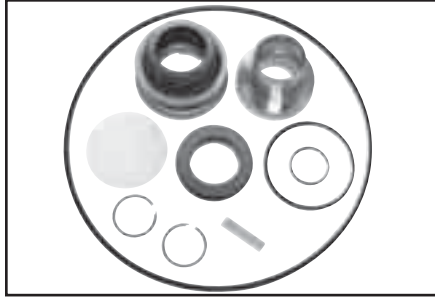

STEP 9

Assembling seal housing assembly and seal seat: Make certain the locator pin is installed inside the hole on the seal housing. Clean seal housing assembly inside and out before inserting the new seal seat. Place a light coat of oil on the seal seat O-ring. Insert the seal seat with the notch pointing down and in line with the locator pin in the back of the seal housing assembly. To protect seal seat during installation, place the small cardboard disk found in the seal assembly package on top of the seal seat. Make sure the cardboard disk is clean. Using your fingers, gently push on the cardboard disc to install the seal seat inside the seal housing. Make sure the locator pin is aligned with the notch in the seal seat.

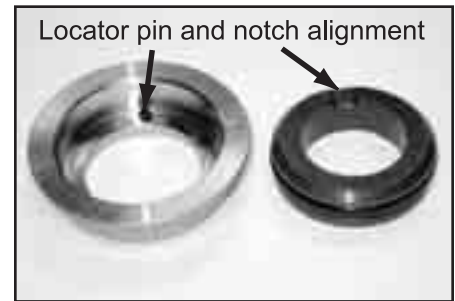

STEP 10

Installation of seal housing O-ring and seal housing: Apply a thin coat of oil to the new seal housing O-ring and install. *NOTE: Insert the O-ring into the groove of the pump casing and hold in place with one finger.* With a pick or small screwdriver, use your other hand to seat the O-ring using a circular motion. Apply a thin coat of oil to the seal housing and press evenly into the pump casing until it snaps into place.



STEP 11

Installation of seal sleeve O-ring:
Clean pump shaft and install the new seal sleeve O-ring. Make sure the O-ring is seated on the shoulder of pump shaft.

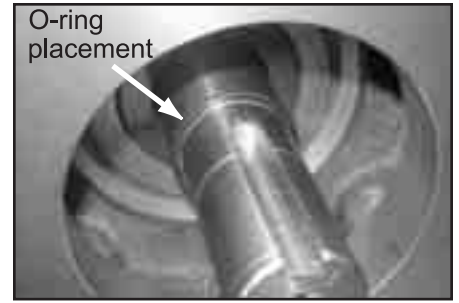
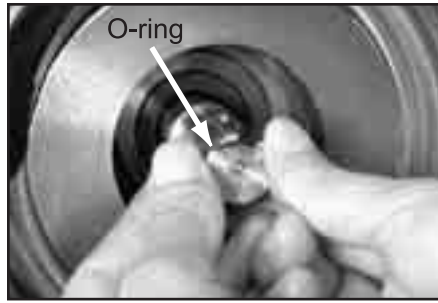

STEP 12

Assembly of seal and seal sleeve:
Apply a thin coat of oil to the carbon face and the O-ring behind the carbon and insert the seal sleeve into the seal by aligning the locating pin on the seal sleeve with the notch/hole on the seal. *NOTE: The current and previous seal assemblies are shown to the right. Although some of the installation photos show the old design, the assembly instructions are the same for the current design.*

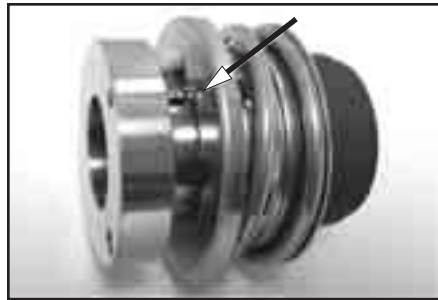

Current design: Part #3189-1X_6

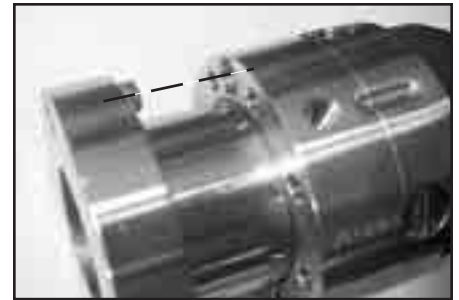

Previous design: Part #5264-X_6

STEP 13

Installation of seal: Before installing your new seal, make sure your hands are clean. Small debris or contamination may cause your seal to leak. Align the seal drive pin with the pump shaft keyway and slide the seal assembly onto the shaft until the seal assembly snaps into place. *NOTE: Although some of the installation photos show the old seal design, the assembly instructions are the same for the current seal design.*



STEP 14

Installation of first retainer ring:
Install the first retainer ring on the shaft near the seal sleeve. *NOTE: In order to seat the retainer ring inside the retainer ring groove, you may use the impeller to compress the seal assembly. Place the impeller on the shaft backwards (hub side in) and push inward until the retainer ring snaps into the groove on the pump shaft. After the retainer ring has been seated into the groove, you will need to remove the impeller. For quick removal, insert one of the cover/head bolts into the impeller and pull. NOTE: Although some of the installation photos show the old seal design, the assembly instructions are the same for the current seal design.*

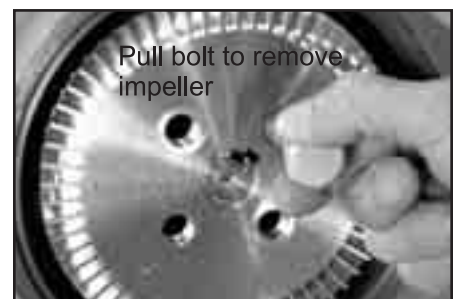
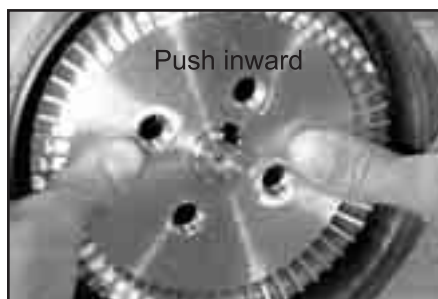

STEP 15

Installation of impeller key: Install the new impeller key into the keyway slot located at the end of the pump shaft. For proper installation, install the impeller with the **hub side out**. The impeller must slide on the shaft freely. If the shaft does not slide freely, carefully remove any burrs from the impeller key and/or keyway with a small file. Remove all fillings from the pump shaft and casing.

NOTE: Although some of the installation photos show the old seal design, the assembly instructions are the same for the current seal design.



STEP 16

Securing impeller and impeller key (second retainer ring): Make certain the impeller is pushed back to the pump casing. To ensure the impeller and impeller key stay in place, the second retainer ring should now be installed in the groove located at the end of the pump shaft. For ease of removal, it is best to overlap one side of the open end of the retainer ring into the keyway opening.

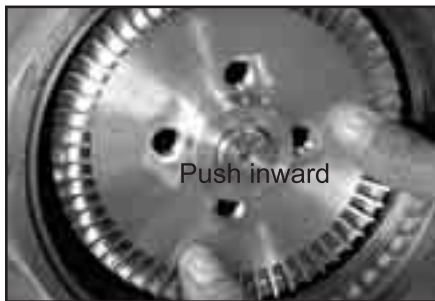

STEP 17

Cover/head installation: Replace the cover/head O-ring, case clearance shim (necessary for older pump models), and cover/head and torque each bolt to 60 ft•lbs. Be certain the Corken label on the cover/head is horizontal and/or upright. On older models, it may be necessary to install more than one clearance shim if the pump will not turn after installation of the cover/head. After assembling the pump, ensure the pump impeller turns freely by rotating the pump shaft with your hand.

NOTE: You must pressurize the pump case with vapor first. After the pump has been pressurized, you may allow liquid to slowly enter the pump.

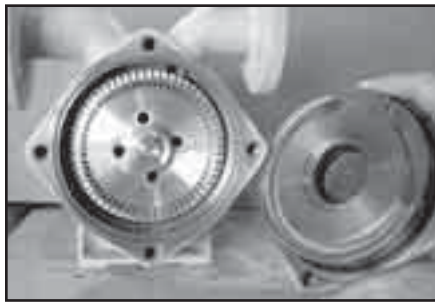

Appendix A—Model Number and Mounting Identification Code for 075-Model Coro-Flo® Pumps

Base Model	FF075	FD075	DLF075	DLD075
Inlet ¹	1-1/2" ANSI	40mm PN40 DIN 2635	1-1/2" ANSI	40mm PN40 DIN 2635
Outlet ¹	1" ANSI	25mm PN40 DIN 2635	1" ANSI	25mm PN40 DIN 2635
Ship Weight, Bare Pump kg (lbs.)	28.6 (63)	28.6 (63)	34 (75)	34 (75)
Description	Frame mounted ANSI flange	Frame mounted DIN flange	Direct mount pump with C-face frame ANSI flange ²	Direct mount pump with C-face frame DIN flange ²

Model Number
Base X X X X

Specification Fields

Motor	No integral motor	Standard	NEMA C-face frame (3–10 hp)	C ³
		N/A	132S/132M Metric (IEC) B14 Face Frame (5.2–7.5 kW)	M ³
Material Selection: Impeller, Seal Sleeve, Seal Housing, Shaft	Bronze impeller, Stainless steel sleeve, Stainless steel seal housing, Steel shaft	Standard		D
	Stainless steel impeller, Stainless steel sleeve, Stainless steel seal housing, Stainless steel shaft	Optional		E
	Steel impeller, Stainless steel sleeve, Stainless steel seal housing, Steel shaft	Optional		F
	Steel impeller, Stainless steel sleeve, Stainless steel seal housing, Stainless steel shaft	Optional		G
Seal Seat Material	Silicon carbide	Standard		6
O-ring Material	Buna-N	Standard		A
	Neoprene ^{®4}	Optional		B
	Viton ^{®4}	Optional		D
	Kalrez ^{®4}	Optional		K

Mounting Options

Description	Model Reference	Part Number	Maximum Motor Frame Size	Ship Weight for Mounting kg (lbs.)
Mounting setup for Direct Drive . Includes steel baseplate, flexible coupling, and coupling guard. PUMP AND MOTOR NOT INCLUDED.	FF075/FD075	101-14	184T	58 (128)
			215T	
			256T	

Part Options

Description	Part Number
Coupling for DLF075 (182/184 TC NEMA frame size)	1345-2
Coupling for DLF075 (213/215 TC NEMA frame size)	1345-1
Coupling for DLF075 (254/256 TC NEMA frame size)	CF
Coupling for DLF/DLD075 (all other NEMA and IEC size C-face motors). Must specify motor frame size.	1345
	CF
Frame adapter (254/256 TC NEMA frame motors)	5210

¹All standard ANSI port sizes are 300 lb.

²Frame adapter listed in the PART OPTIONS table is required for NEMA motors over 10 hp (215 TC frame size). Special frame or adapter required for IEC motors over 7.5 kW. Consult factory for assistance.

³Motor is not included.

⁴Kalrez®, Neoprene®, and Viton® are registered trademarks of the DuPont company.

Appendix A—Model Number and Mounting Identification Code for 150-Model Coro-Flo® Pumps

Base Model	FF150	FD150	DLF150	DLD150	Model Number Base X X X X
Inlet ¹	1-1/2" ANSI	40mm PN40 DIN 2635	1-1/2" ANSI	40mm PN40 DIN 2635	
Outlet ¹	1" ANSI	25mm PN40 DIN 2635	1" ANSI	25mm PN40 DIN 2635	
Ship Weight, Bare Pump kg (lbs.)	28.6 (63)	28.6 (63)	34 (75)	34 (75)	
Description	Frame mounted ANSI flange	Frame mounted DIN flange	Direct mount pump with C-face frame ANSI flange ²	Direct mount pump with C-face frame DIN flange ²	

Specification Fields

Motor	No integral motor	Standard	NEMA C-face frame (3–10 hp)	C ³
		N/A	132S/132M Metric (IEC) B14 Face Frame (5.5–7.5 kW)	M ³
Material Selection: Impeller, Seal Sleeve, Seal Housing, Shaft	Bronze impeller, Stainless steel sleeve, Stainless steel seal housing, Steel shaft	Standard		D
	Stainless steel impeller, Stainless steel sleeve, Stainless steel seal housing, Stainless steel shaft	Optional		E
	Steel impeller, Stainless steel sleeve, Stainless steel seal housing, Steel shaft	Optional		F
	Steel impeller, Stainless steel sleeve, Stainless steel seal housing, Stainless steel shaft	Optional		G
Seal Seat Material	Silicon carbide	Standard		6
O-ring Material	Buna-N	Standard		A
	Neoprene ^{®4}	Optional		B
	Viton ^{®4}	Optional		D
	Kalrez ^{®4}	Optional		K

Mounting Options

Description	Model Reference	Part Number	Maximum Motor Frame Size	Ship Weight for Mounting kg (lbs.)
Mounting setup for Direct Drive . Includes steel baseplate, flexible coupling, and coupling guard. PUMP AND MOTOR NOT INCLUDED.	FF150/FD150	101-14	184T	58 (128)
			215T	
			256T	

Part Options

Description	Part Number
Coupling for DLF150 (182/184 TC NEMA frame size)	1345-2
Coupling for DLF150 (213/215 TC NEMA frame size)	1345-1
Coupling for DLF150 (254/256 TC NEMA frame size)	CF
Coupling for DLF/DLD150 (all other NEMA and IEC size C-face motors). Must specify motor frame size.	1345
	CF
Frame adapter (254/256 TC NEMA frame motors)	5210

¹All standard ANSI port sizes are 300 lb.

²Frame adapter listed in the PART OPTIONS table is required for NEMA motors over 10 hp (215 TC frame size). Special frame or adapter required for IEC motors over 7.5 kW. Consult factory for assistance.

³Motor is not included.

⁴Kalrez®, Neoprene®, and Viton® are registered trademarks of the DuPont company.

Appendix B—Material and Mechanical Specifications for 075- and 150-Model Coro-Flo® Pumps

Equipment Type & Options

Regenerative turbine liquid pump
 Foot mounted (FF075, FF150, FD075, or FD150)
 Direct mounted (DLF075, DLF150, DLD075, or DLD150)
 All have either 300# ANSI or DIN flanges

Applications

Under & aboveground autogas dispensing
 Multiple cylinder filling stations
 Vaporizer feed—high pressure
 Direct, high pressure asphalt burner feed

Features & Benefits

Regenerative turbine type:	Able to handle liquefied gases without flashing
High flows and differential pressures:	Ideal for dual hose dispensers and multiple dispensers
Heavy duty bearings:	Long bearing life
Single mechanical seal:	Very easy seal replacement and maintenance
Floating impeller:	Long impeller life, lower maintenance
ANSI or Din, metric fasteners optional:	Usability for US or overseas applications
Runs at 50 or 60 cycle (Hz):	Usability for US or overseas applications
Two mounting options:	Versatility for your installation

Operating Specifications

Inlet: 1-1/2" ANSI 300# RF (DIN opt.)	Max. diff. press. for 075-Model: 150 psig (10.3 bar)
Outlet: 1" ANSI 300# RF (DIN opt.)	Max. diff. press. for 150-Model: 250 psig (17.2 bar)
RPM: 3450 @ 60 Hz, 2880 @ 50 Hz	Temperature range: -25° to 225°F (-32° to 107°C)
Max. wrk. press.: 400 psig (27.6 bar)	Flow range for 075-Model: 10–40 gpm (37.9 to 151.4 L/min)
Maximum driver: 20 hp (15 kW)	Flow range for 150-Model: 12–58 gpm (45.4 to 219.6 L/min)

Material Specifications

Part	Model	Standard Material	Optional Material
Case, cover	All	Ductile iron ASTM A536	
Impeller	All	Copper alloy ASTM B584, UNS C92300 (also known as Navy Bronze)	Steel Stainless steel
Impeller key	All	Steel, zinc plated	
Seal seat	All	Silicon Carbide	
Seal rotor	All	Carbon	
Seal metal parts	All	Stainless steel	
Seal sleeve	All	Stainless steel	
Seal housing	All	Stainless steel	
Shaft	All	Steel	Stainless steel
Frame	FF/FD	Gray iron ASTM A48, Class 30	
	DLF/DLD	Ductile iron ASTM A536	
Bearing cap	All	Ductile iron	
O-rings	All	Buna-N	Neoprene®, Viton®, Buna-N, Kalrez® ¹
Retainer Rings	All	Steel	
Bearings	All	Ball	

¹Neoprene®, Viton®, and Kalrez® are registered trademarks of the DuPont company.

Appendix C—Performance Curves for 075-Model Coro-Flo® Pumps¹

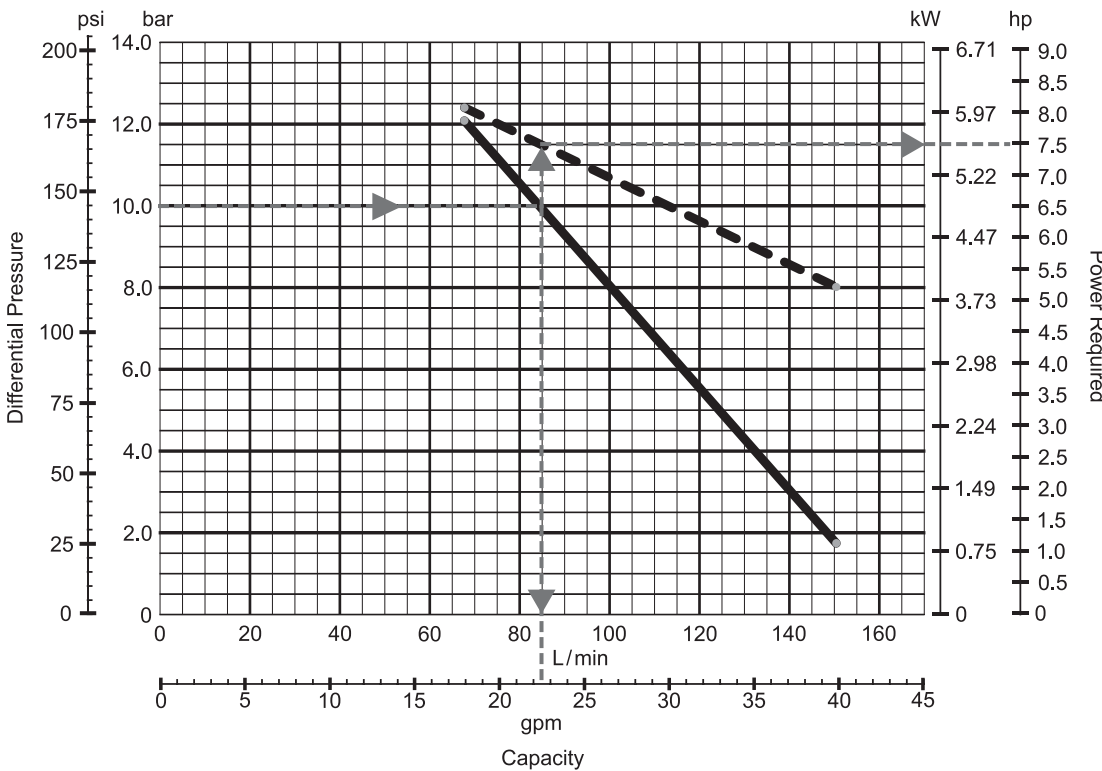
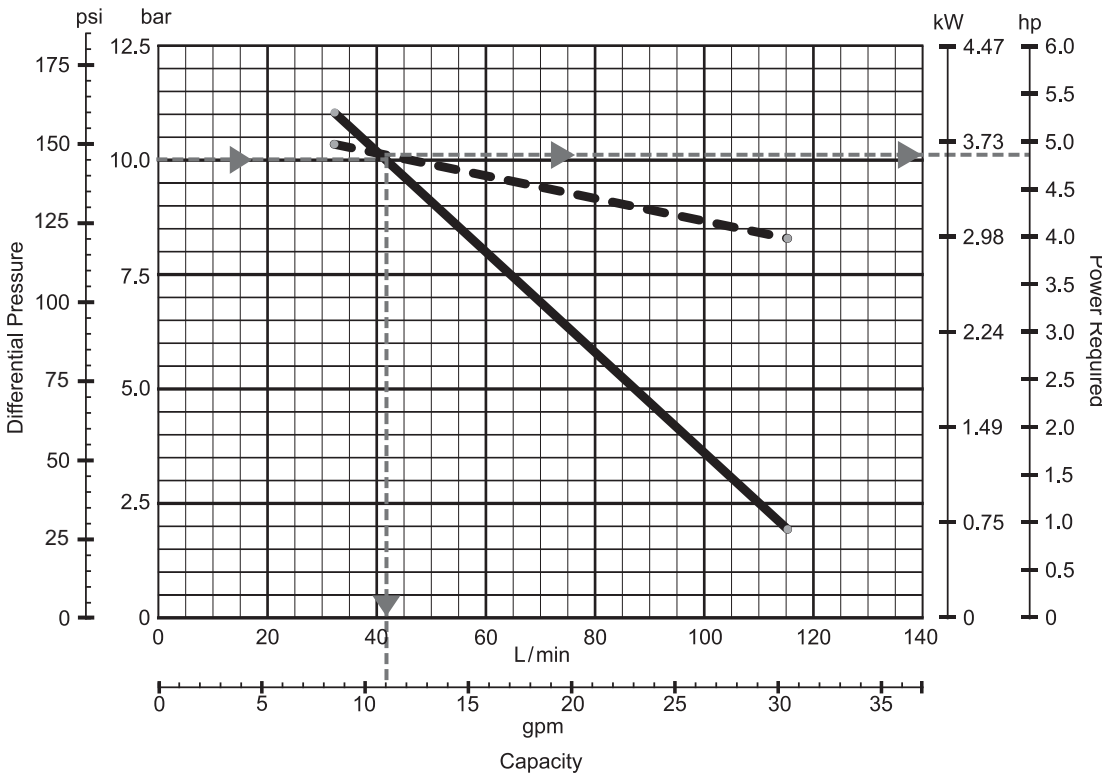

¹The performance curves are based on aboveground LPG installations. Performance curves for underground LPG tanks will vary based on the specific installation. Consult factory.

Appendix C—Performance Curves for 150-Model Coro-Flo® Pumps¹

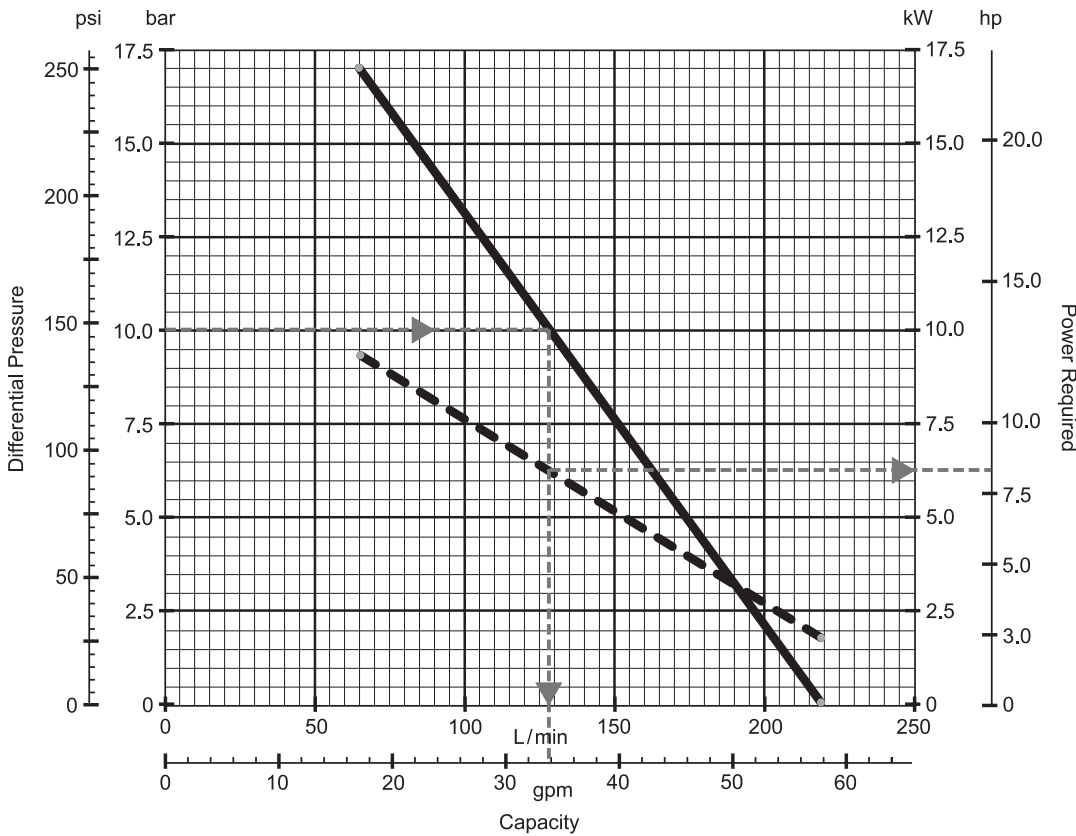
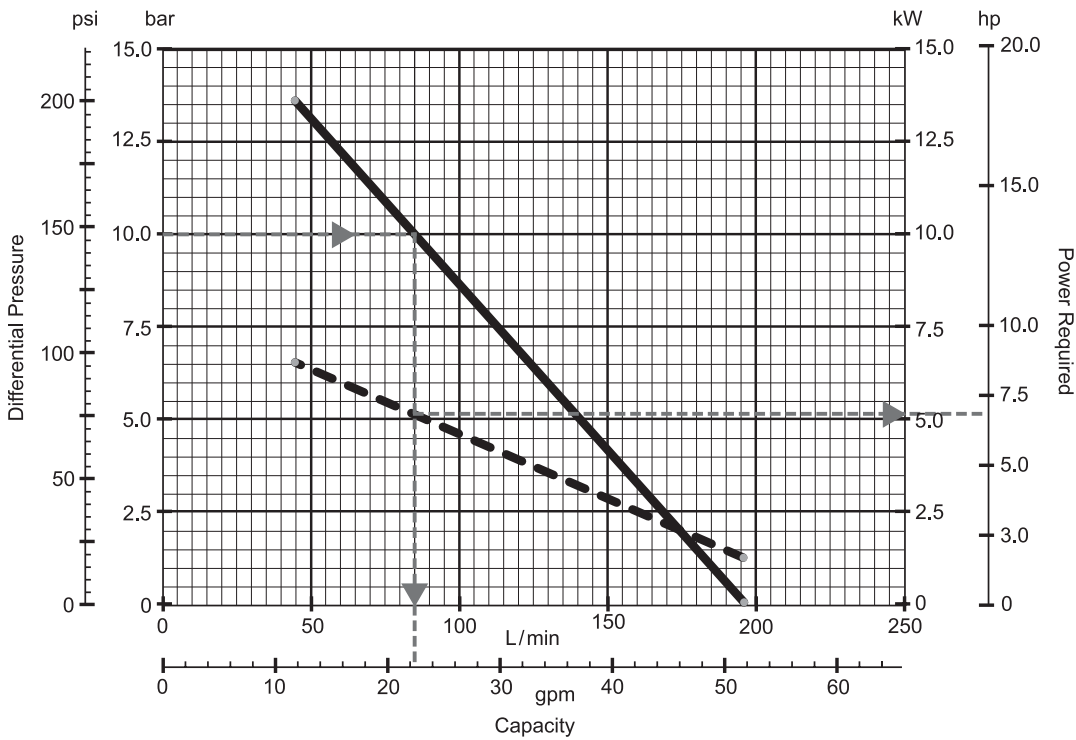

¹The performance curves are based on aboveground LPG installations. Performance curves for underground LPG tanks will vary based on the specific installation. Consult factory.

Appendix D—Outline Dimensions for 075- and 150-Model Coro-Flo® Pumps

Frame Mount ANSI Flange (FF) and DIN Flange (FD)

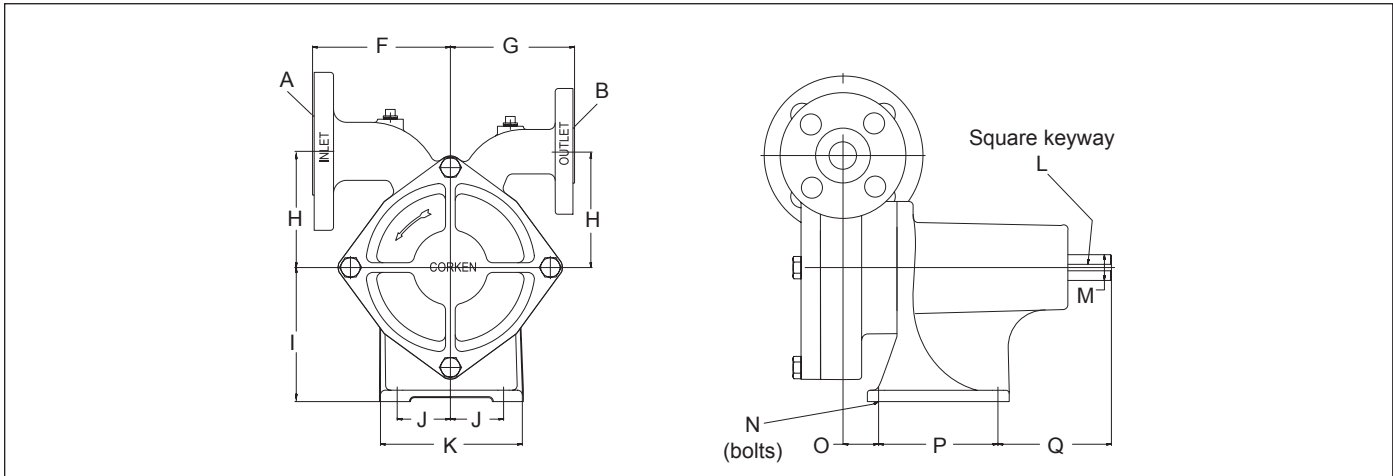

Direct Mount ANSI Flange (DLF) and DIN Flange (DLD)

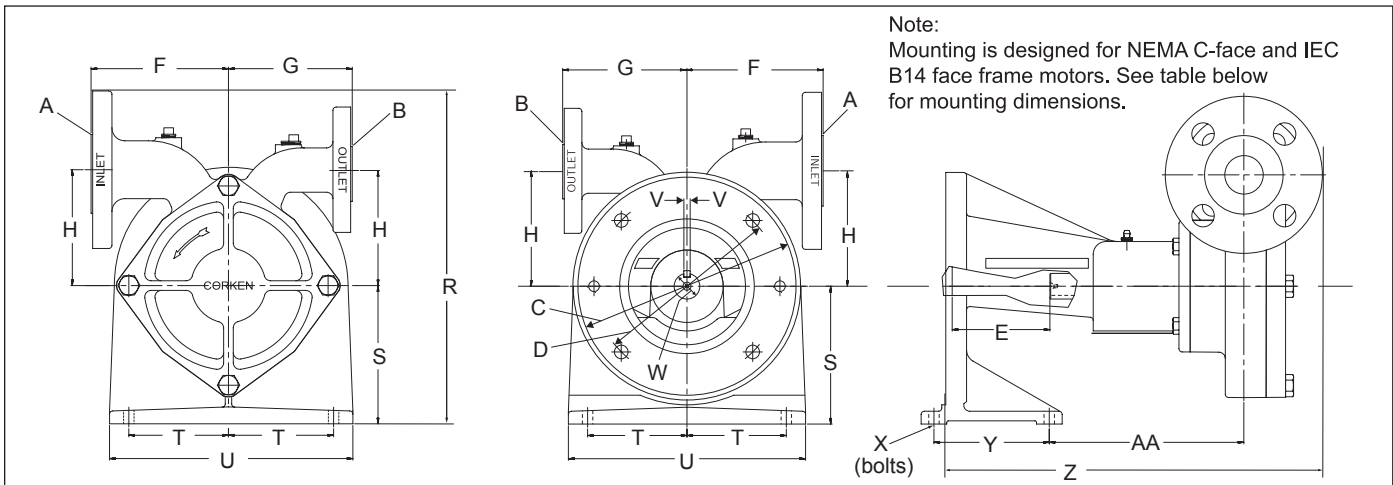

Flange Dimensions		
Model	A (inlet)	B (outlet)
FF075 FF150	1-1/2" ANSI 300#	1" ANSI 300#
FD075 FD150	DIN 2635, 40 PN, 40 mm	DIN 2635, 40 PN, 25 mm

Motor Mounting Dimensions			
Type	C	D	E
NEMA	8-1/2"	7-1/4"	3-13/16"
IEC	165 mm	130 mm	90.75 mm

Outline Dimensions—Inches (Centimeters)										
F	G	H	I	J	K	L	M	N	O	P
5-5/16 (13.57)	4-13/16 (12.23)	4-1/2 (11.43)	5-13/64 (13.20)	2-1/16 (5.24)	5-1/2 (13.97)	1/4 (0.63)	1 diameter (2.54)	3/8 bolts (0.95)	1-3/8 (3.50)	4-5/8 (11.75)

Outline Dimensions—Inches (Centimeters)										
Q	R	S	T	U	V	W	X	Y	Z	AA
4-3/8 (11.18)	12-15/16 (32.86)	5-3/8 (13.65)	3-7/8 (9.84)	9-1/4 (23.50)	1/4 (0.63)	1 (25.4)	5/16 bolts (0.79)	4-1/2 (11.42)	14-3/8 (36.51)	7-19/32 (19.27)

Appendix D—Outline Dimensions for 075- and 150-Model Coro-Flo® Pumps

Frame Mount ANSI Flange (FF) and DIN Flange (FD) with -101 Mounting

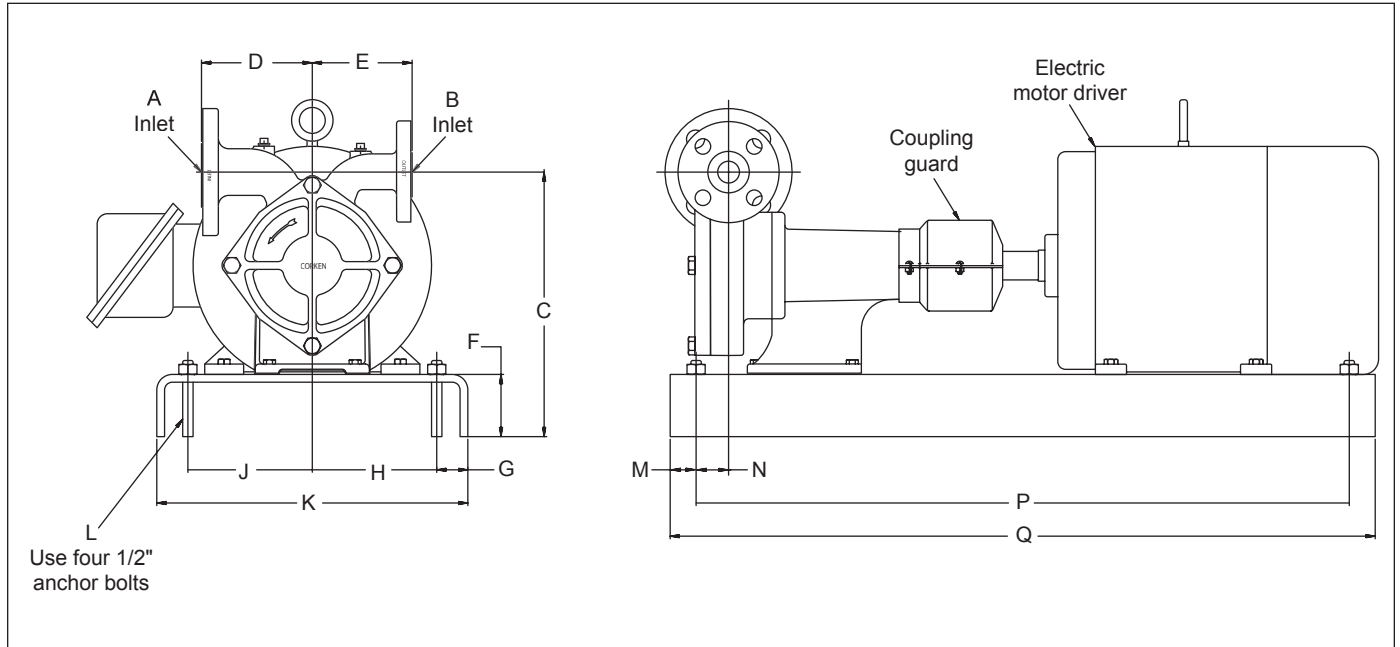

Flange Dimensions		
Model	A (inlet)	B (outlet)
FF075 FF150	1-1/2" ANSI 300#	1" ANSI 300#
FD075 FD150	DIN 2635, 40 PN, 40 mm	DIN 2635, 40 PN, 25 mm

C Dimensions All Models	
182T–215T Frame	12-3/4" (32.40)
254T–256T Frame	13-3/4" (34.94)

Outline Dimensions For 182T–256T Frame—Inches (centimeters)											
D	E	F	G	H	J	K	L	M	N	P	Q
5-11/32 (13.57)	4-13/16 (12.23)	3 (7.62)	1-1/2 (3.81)	6 (15.24)	6 (15.24)	15 (38.10)	1/2 Bolts (1.27)	1-1/4 (3.17)	1-9/16 (3.97)	31-1/2 (80.01)	34 (86.36)

Appendix E—Parts Details for 075- and 150-Model Coro-Flo® Pumps

Frame Mount ANSI Flange (FF) and Din Flange (FD)

O-ring Code Chart	
A	Buna-N
B	Neoprene ^{®1}
D	Viton ^{®1}
G	Ethylene Propylene
K	Kalrez ^{®1}

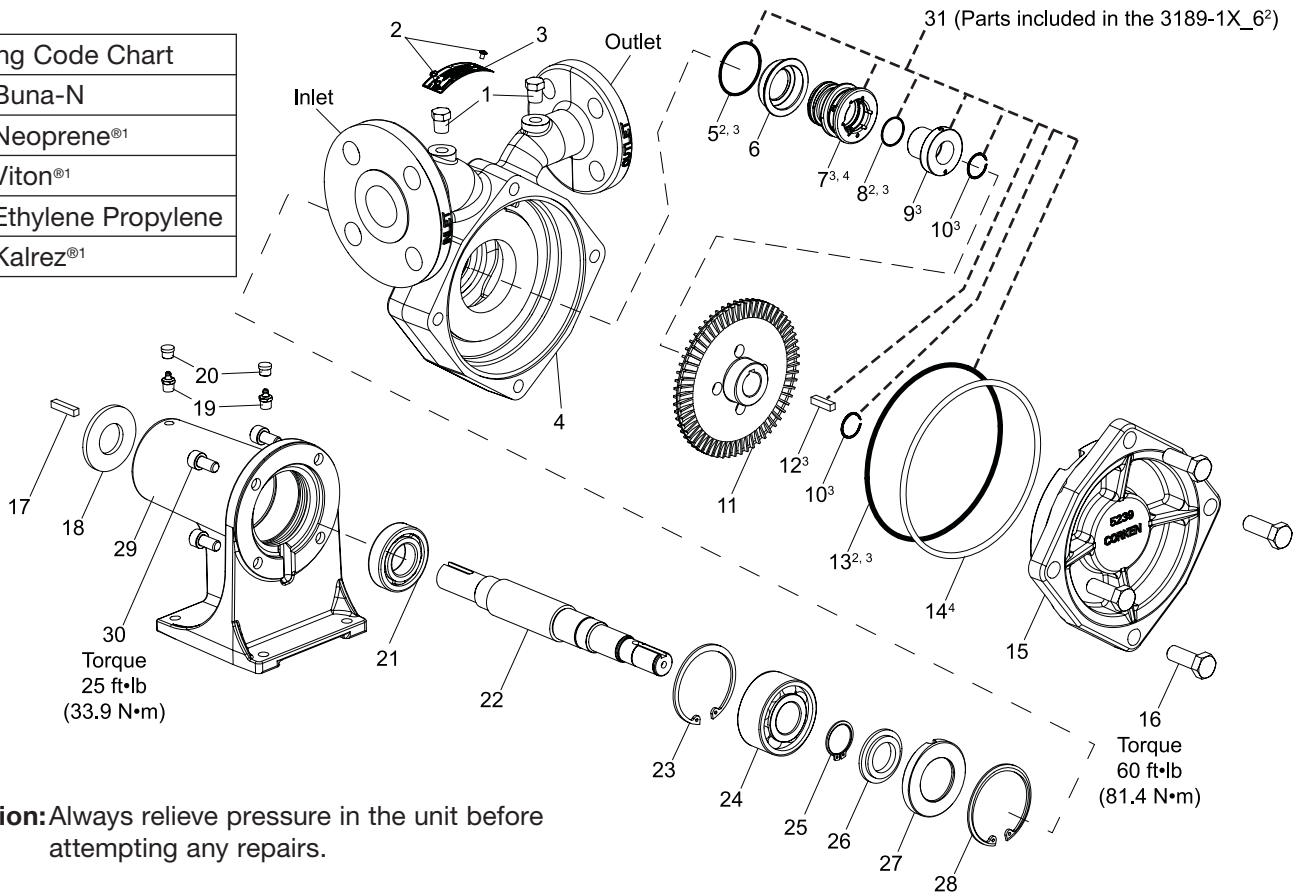

Caution: Always relieve pressure in the unit before attempting any repairs.

No	Part no	Description	Qty
1	3442	1/4" pipe plug	2
2	7012-0065F019E	Nameplate screw	2
3	1914-1	Nameplate	1
4	5238-75	075 Case—ANSI flange (FF)	1
	5238	150 Case—ANSI flange (FF)	1
	5238-751	075 Case—DIN flange (FD)	1
	5238-1	150 Case—DIN flange (FD)	1
5	2-133_2,3	Seal housing O-ring	1
6	5244-1X	Seal housing assembly	1
7	Not sold separately ³	Seal sub assembly	1
8	2-018_2,3	Seal sleeve O-ring	1
9	Not sold separately ³	Seal sleeve assembly	1
10	2760-88 ³	7/8" retainer ring	1
11	5240-75	075 Impeller (bronze)	1
	5240	150 Impeller (bronze)	1
	5240-751	075 Impeller (stainless steel)	1
	5240-1	150 Impeller (stainless steel)	1
	5240-752	075 Impeller (steel)	1
	5240-2	150 Impeller (steel)	1

No	Part no	Description	Qty
12	4244 ³	Impeller key	1
13	2-260_2,3	Case O-ring	1
14	5248 ⁴	Case clearance shim	1
15	5239-75	075-Cover	1
	5239	150-Cover	1
16	7301-140MC040A	M14-2 x 40mm hex head bolt	4
17	3226	Shaft key	1
18	3227	Bearing plate	1
19	2158	Grease zerk	2
20	2159	Lubricap	2
21	2759	Single row ball bearing	1
22	5241-1	Shaft	1
23	5000-281	Retainer ring	1
24	2758	Double row ball bearing	1
25	5102-118	Retainer ring	1
26	1006	Grease seal	1
27	1238	Bearing cap	1
28	5002-281	Retainer ring	1
29	1010-3	Mounting frame	1
30	7302-100MC020A	M10-1.5 x 22mm Allen head bolt	4
31	3189-1X_6 ²	Seal assembly	1

¹Registered trademark of the DuPont company

²_ denotes O-ring code

³Included in seal assembly 3189-1X_6²

⁴The case clearance shim only applies to models prior to serial number prefix YU. For a complete explanation of Corken's serial number prefix codes, see page A400 (latest version) located in the "Policy and Prices" section of your sales catalog or service manual.

Appendix E—Parts Details for 075- and 150-Model Coro-Flo® Pumps

Direct Mount ANSI Flange (DLF) and Din Flange (DLD)

O-ring Code Chart	
A	Buna-N
B	Neoprene ^{®1}
D	Viton ^{®1}
G	Ethylene Propylene
K	Kalrez ^{®1}

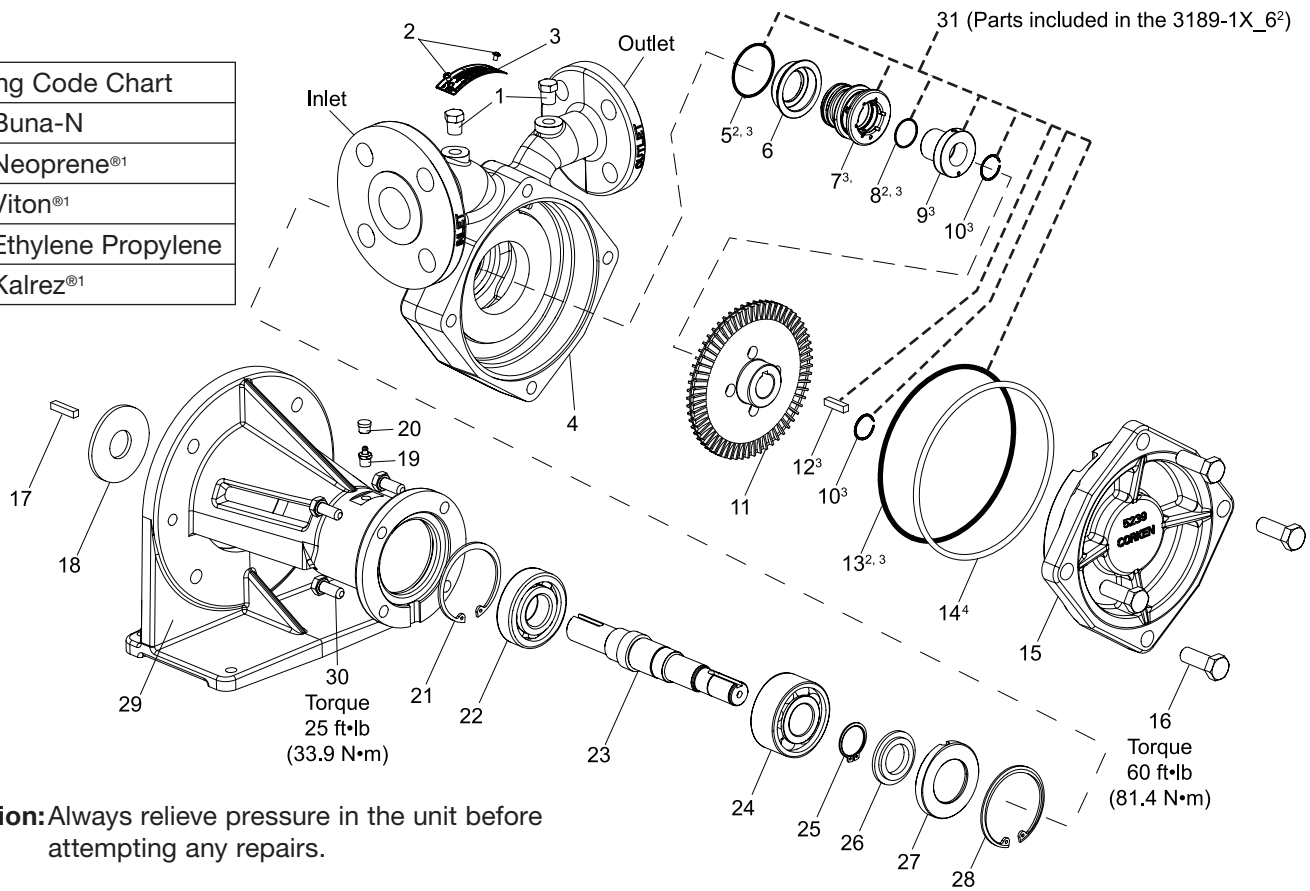

Caution: Always relieve pressure in the unit before attempting any repairs.

No	Part no	Description	Qty
1	3442	1/4" pipe plug	2
2	7012-0065F019E	Nameplate screw	2
3	1914-1	Nameplate	1
4	5238-75	075 Case—ANSI flange (FF)	1
	5238	150 Case—ANSI flange (FF)	1
	5238-751	075 Case—DIN flange (FD)	1
	5238-1	150 Case—DIN flange (FD)	1
5	2-133_2,3	Seal housing O-ring	1
6	5244-X1	Seal housing assembly	1
7	Not sold separately ³	Seal sub assembly	1
8	2-018_2,3	Seal sleeve O-ring	1
9	Not sold Separately	Seal sleeve assembly	1
10	2760-88 ³	7/8" retainer ring	1
11	5240-75	075 Impeller (bronze)	1
	5240	150 Impeller (bronze)	1
	5240-751	075 Impeller (stainless steel)	1
	5240-1	150 Impeller (stainless steel)	1
	5240-752	075 Impeller (steel)	1
	5240-2	150 Impeller (steel)	1

No	Part no	Description	Qty
12	4244 ³	Impeller key	1
13	2-260_2,3	Case O-ring	1
14	5248 ⁴	Case clearance shim	1
15	5239-75	075-Cover	1
	5239	150-Cover	1
16	7301-140MC040A	M14-2 x 40mm hex head bolt	4
17	3226	Shaft key	1
18	4377	Bearing plate	1
19	2158	Grease zerker	1
20	2159	Lubricap	1
21	5000-281	Retainer ring	1
22	4378	Single row ball bearing	1
23	5241-2	Shaft	1
24	2758	Double row ball bearing	1
25	5102-118	Retainer ring	1
26	1006	Grease seal	1
27	1238	Bearing cap	1
28	5002-281	Retainer ring	1
29	4298	Mounting frame—NEMA	1
	4298-1	Mounting frame—IEC	1
30	7301-100MC025A	M10-1.5 x 25mm hex head bolt	4
31	3189-1X_6 ²	Seal assembly	1

¹Registered trademark of the DuPont company

²_ denotes O-ring code

³Included in seal assembly 3189-1X_6²

⁴The case clearance shim only applies to models prior to serial number prefix YU. For a complete explanation of Corcoran's serial number prefix codes, see page A400 (latest version) located in the "Policy and Prices" section of your sales catalog or service manual.

Appendix F—Installation Tips for Above Ground Applications

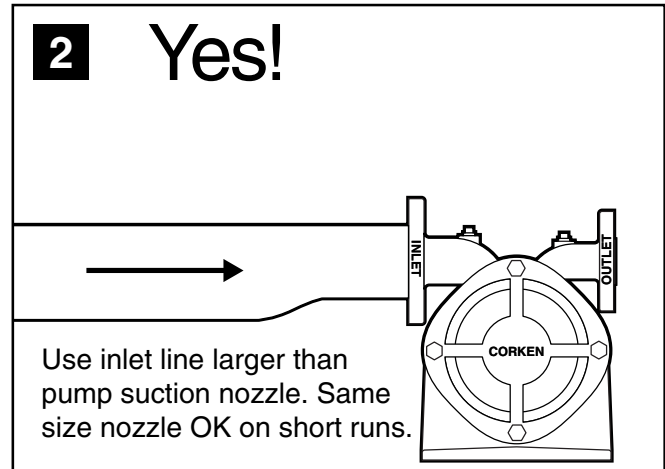
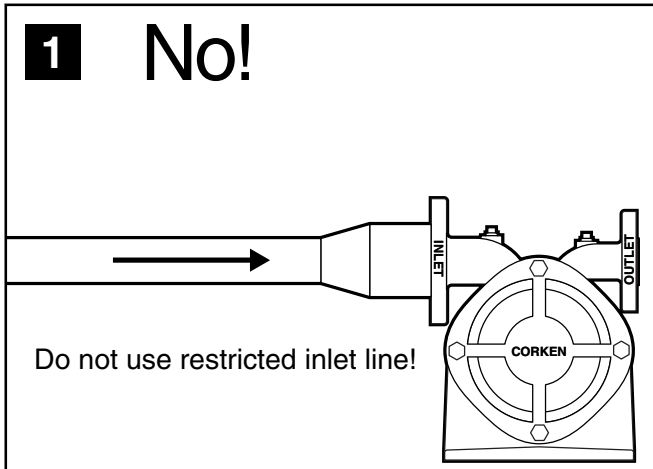

Pressure drop caused by restriction in suction line will cause vaporization and cavitation.

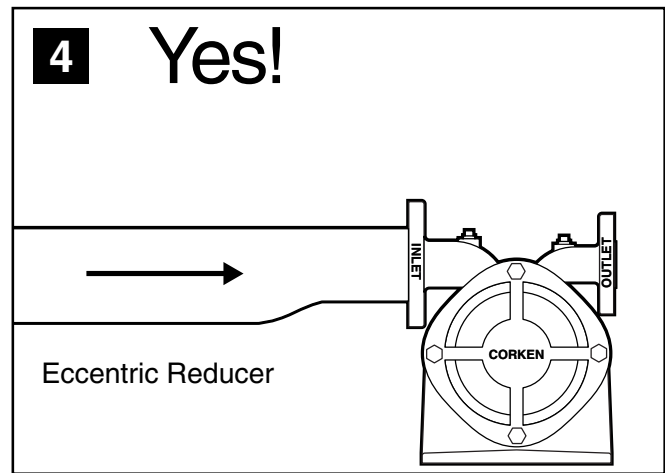
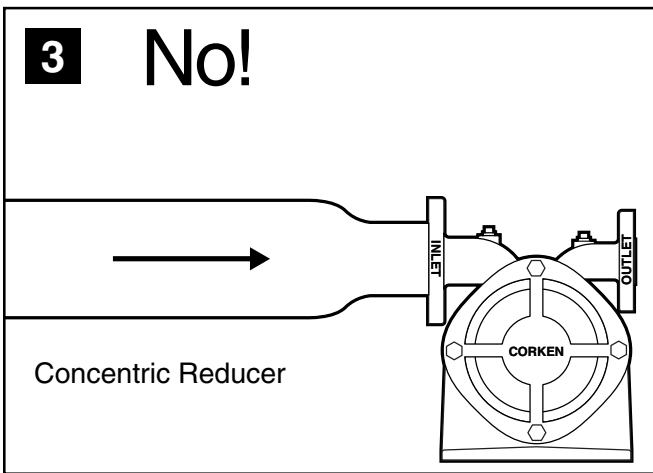

An eccentric reducer should always be used when reducing into any pump inlet where vapor might be encountered in the pumpage. The flat upper portion of the reducer prevents an accumulation of vapor that could interfere with pumping action.

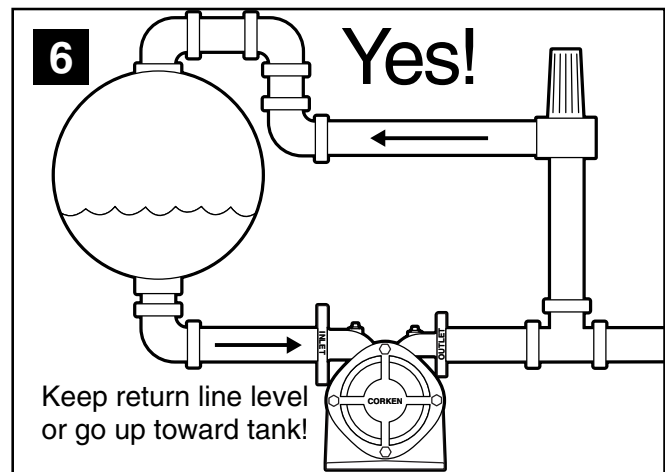
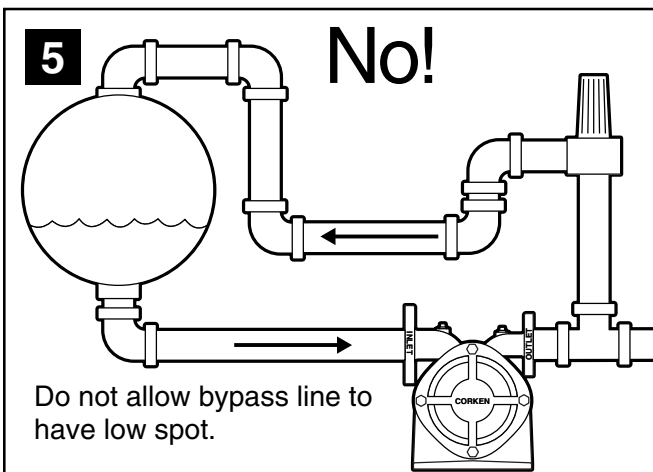

Low spots in bypass line can collect liquid which prevents normal vapor passage for priming purposes just like the P trap in the drain of a kitchen sink. This is not a problem for bypass lines where vapor elimination is not required.

Appendix F—Installation Tips for Above Ground Applications

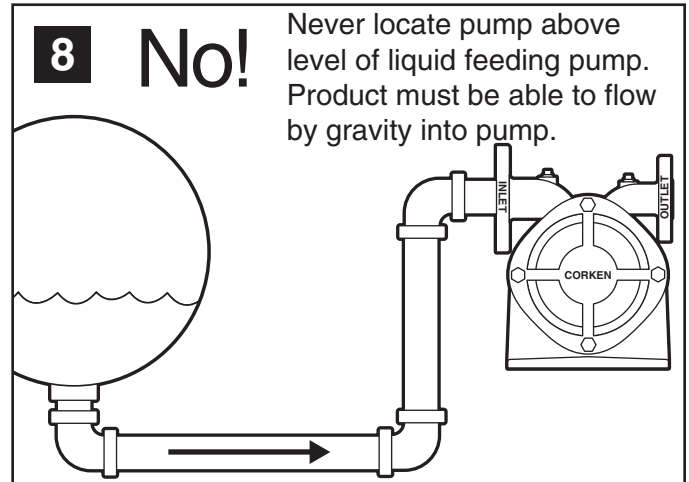
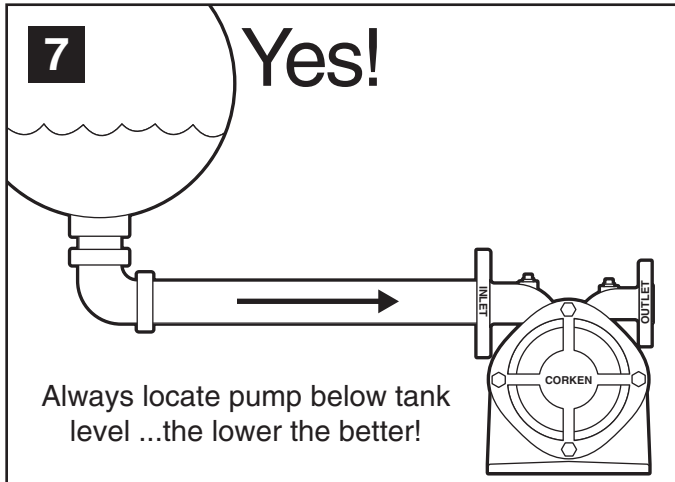

Since liquefied gases boil when drawn into a pump by its own suction, the pump must be fed by gravity flow to give stable, trouble-free operation.

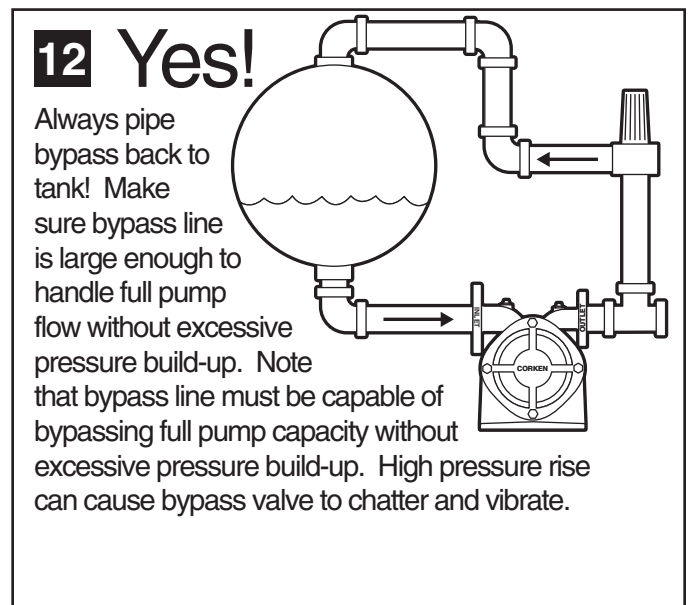
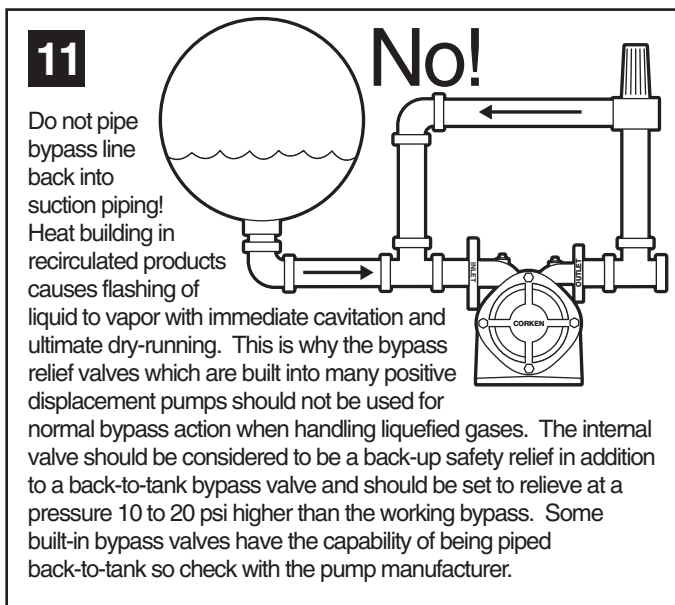
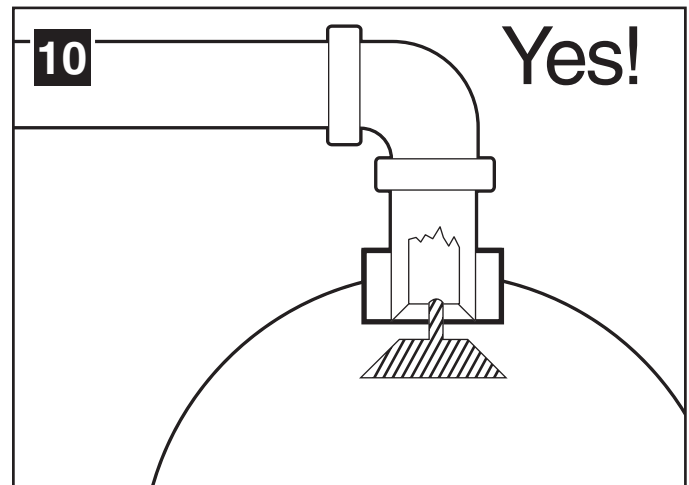
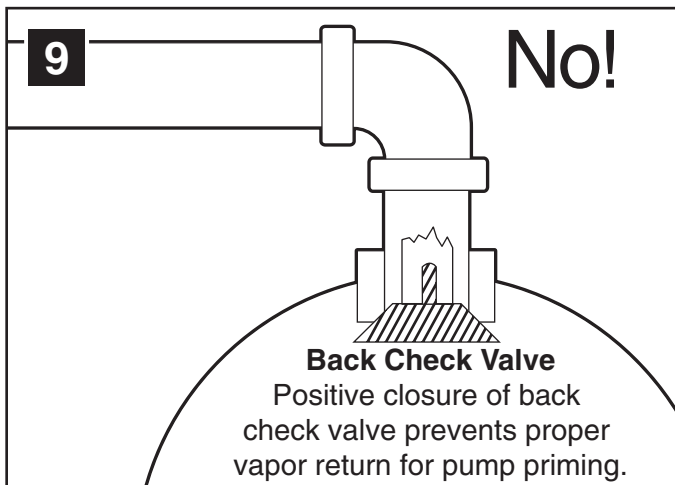

Appendix F—Installation Tips for Above Ground Applications

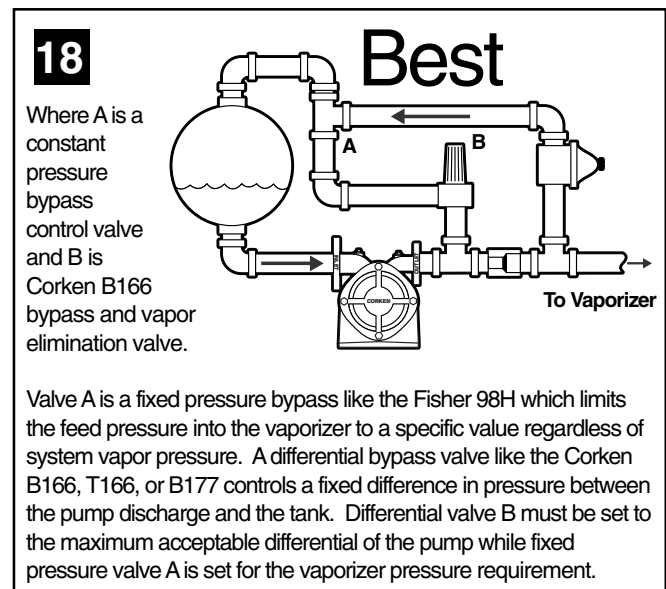
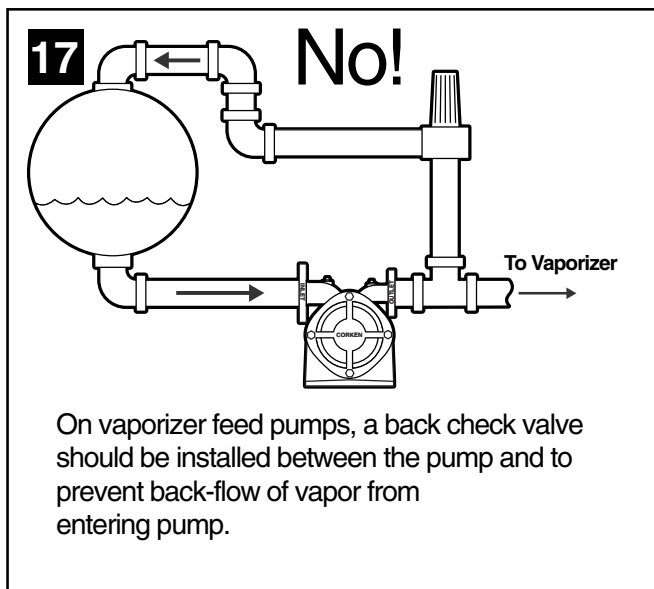
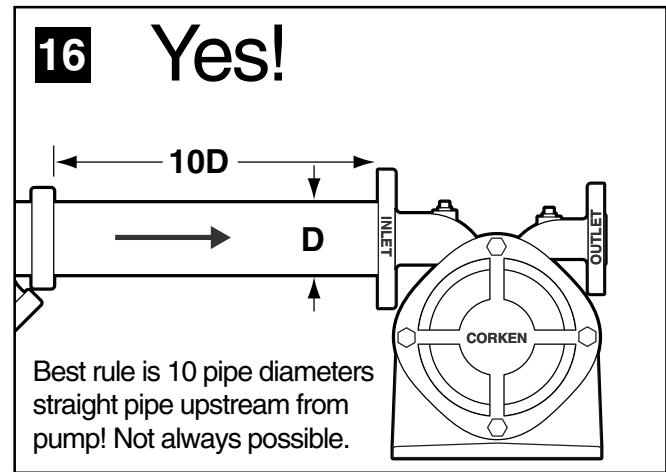
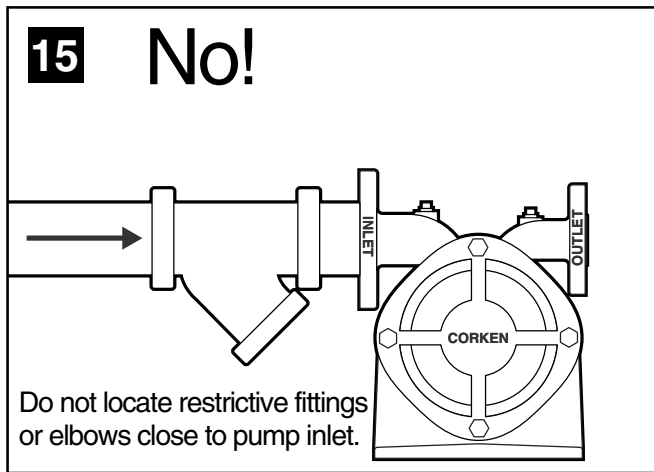
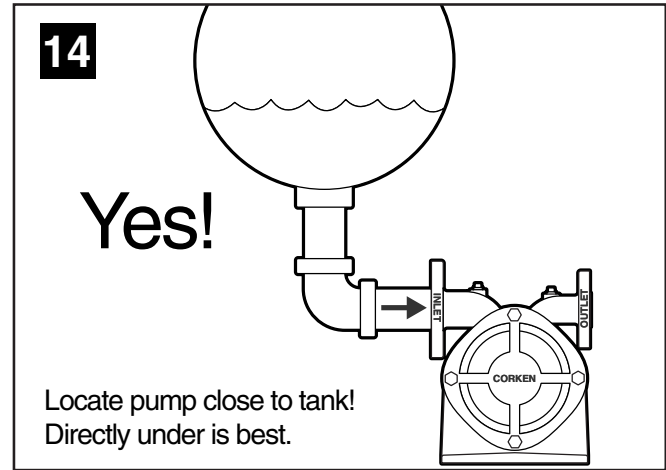
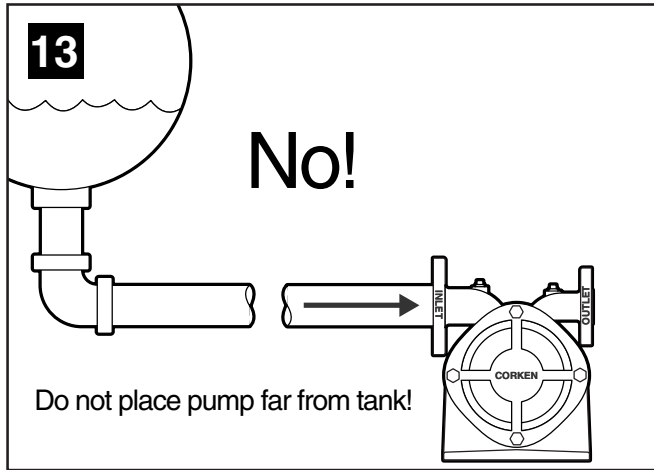

Appendix F—Installation Tips for Underground Tank Applications

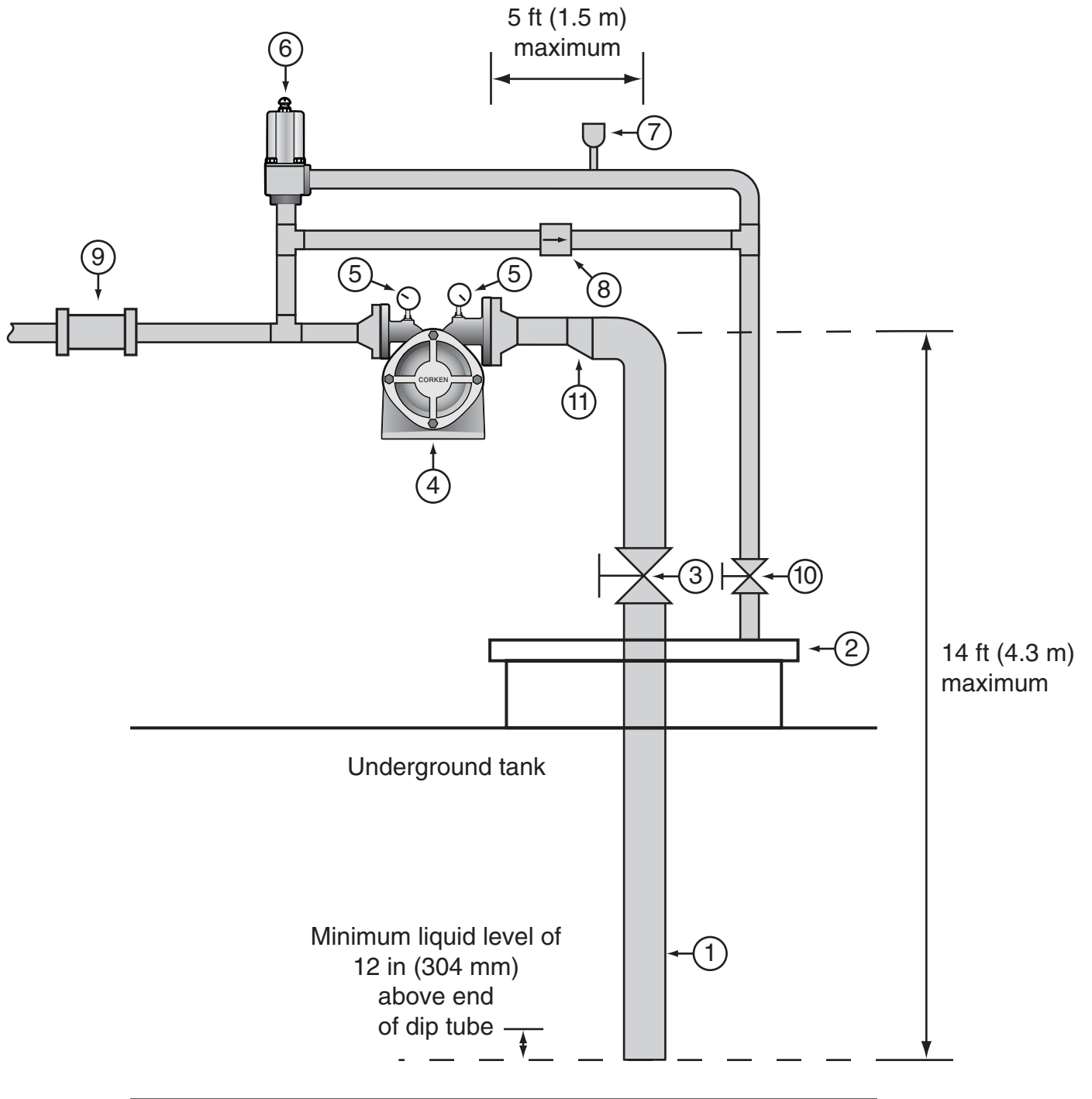

Appendix F—Installation Tips for Underground Tank Applications

Typical Bill of Materials

Ref. No.	Description	Remarks
1	1.5", schedule 80 pipe	Model 075 series pump
	2", schedule 80 pipe	Model 150 series pump
2	Man way cover	Existing
3	2" ball valve, full port	Manual or remote control
4	Corken 075 series pump	With 5.0 hp (3.7 kW) electric motor
	Corken 150 series pump	With 7.5 hp (5.5 kW) electric motor
5	¼" NPT pressure gauge	0–400 psig (0–28 bar g)
6	Corken B166 bypass valve 1" NPT	With spring code C
7	¼" NPT hydrostatic relief valve	Set at 450 psig (31 bar g)
8	In-line excess flow valve	Closing flow of 10–15 gpm (37–57 L/min)
9	Back pressure check valve	Like Corken's Flo-Chek valve
10	Bypass return line's valve	Existing
11	2" x 1½" eccentric reducer	

Warning:

1. No excess flow valves on the tank's liquid outlet connections are shown in these schematics. If local regulations require the use of excess flow valves, its closing flow should be approximately 1.5 times higher than the pump's rated capacity for the operational conditions.
2. Periodic inspection and maintenance of Corken products is essential.
3. Only experienced, trained and qualified personnel are to make inspection, maintenance and installation of Corken products.
4. Maintenance, use and installation of Corken products must comply with Corken instructions, applicable laws and safety standards such as NFPA 58 for LP-Gas and ANSI K6.1-1972 for Anhydrous Ammonia.
5. Transfer of toxic, dangerous, flammable or explosive substances using Corken equipment is at the user's risk. Only qualified personnel should operate Corken equipment according to the applicable laws and safety standards.

Appendix F—Installation Tips for Underground Tank Applications Utilizing a Submersible Pump Manifold

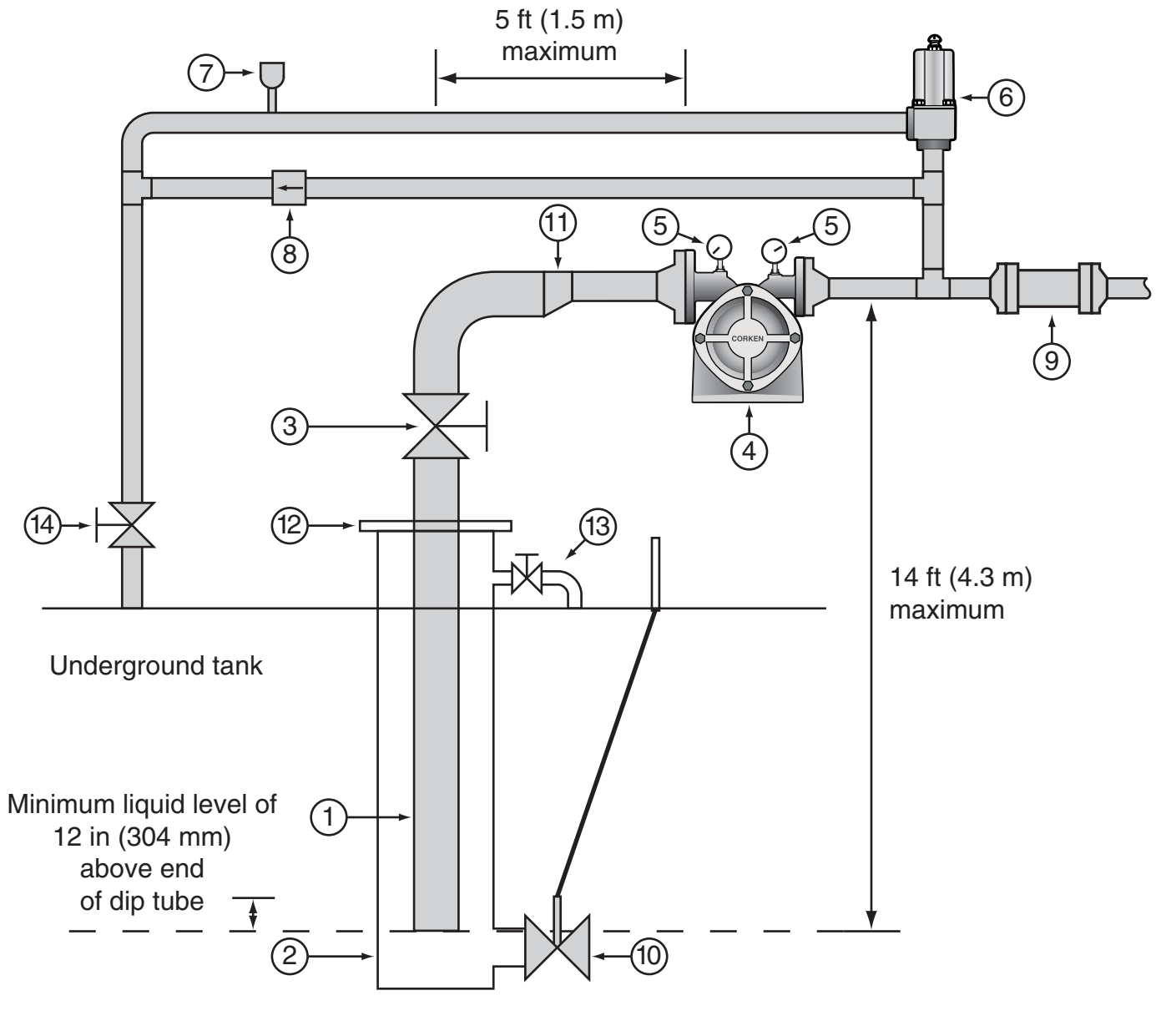

Appendix F—Installation Tips for Underground Tank Applications Utilizing a Submersible Pump Manifold

Typical Bill of Materials

Ref. No.	Description	Remarks
1	1.5", schedule 80 pipe	Model 075 series pump
	2", schedule 80 pipe	Model 150 series pump
2	5" manifold	Existing
3	2" ball valve, full port	Manual or remote
4	Corken 075 series pump	With 5.0 hp (3.7 kW) electric motor
	Corken 150 series pump	With 7.5 hp (5.5 kW) electric motor
5	¼" NPT pressure gauge	0–400 psig (0–28 bar g)
6	Corken B166 bypass valve 1" NPT	With spring code C
7	¼" NPT hydrostatic relief valve	Set at 450 psig (31 bar g)
8	In-line excess flow valve	Closing flow of 10–15 gpm (37–57 L/min)
9	Back pressure check valve	Like Corken's Flo-Chek valves
10	2" ball valve	Existing
11	2" x 1½" eccentric reducer	
12	5" flange	Existing
13	Pressure equalizing line	Part of existing 5" manifold. Must be open for pump to operate properly.
14	Bypass return line's valve	Existing

Warning:

1. No excess flow valves on the tank's liquid outlet connections are shown in these schematics. If local regulations require the use of excess flow valves, its closing flow should be approximately 1.5 times higher than the pump's rated capacity for the operational conditions.
2. Periodic inspection and maintenance of Corken products is essential.
3. Only experienced, trained and qualified personnel are to make inspection, maintenance and installation of Corken products.
4. Maintenance, use and installation of Corken products must comply with Corken instructions, applicable laws and safety standards such as NFPA 58 for LP-Gas and ANSI K6.1-1972 for Anhydrous Ammonia.
5. Transfer of toxic, dangerous, flammable or explosive substances using Corken equipment is at the user's risk. Only qualified personnel should operate Corken equipment according to the applicable laws and safety standards.

Appendix G—Troubleshooting Guide

In diagnosing pump and “system” troubles, the following information is essential:

1. Pump model and serial number
2. Electric motor; hp and RPM
3. Product specific gravity
4. Product temperature
5. Pressure at pump’s suction port
6. Pressure at pump’s discharge port
7. Pressure in the storage tank
8. Pressure in the tank being filled

Problem	Cause	What To Do
Low Capacity	Pump speed too low Wrong electric motor	Check the RPM of the electric motor.
	High differential pressure	Remove the restrictions in the discharge piping / hose, or increase their sizes.
	Vapor lock	Regenerative turbine pumps “vapor-lock” when reaching their maximum differential pressure capability. See above for high differential pressure.
	Bypass valve stuck open or set too low	Readjust, repair or replace the bypass valve
	Clogged strainer	Clean strainer screen.
	Worn impeller	Replace the impeller.
	Suction pipe too small or restricted	Indicated by pump’s inlet pressure dropping when the pump is started. Remove restrictions and/or increase pipe size.
Pump runs but no flow	Valve closed	Check valves and make sure they are in the open position.
	Excess flow valve slugged or closed	Stop pump until the excess flow valve opens. If the problem continues, install a new or larger capacity excess flow valve.
	Wrong rotation	Check the rotation of the electric motor and change the rotation.
	Suction pipe too small or restricted	Indicated by pump’s inlet pressure dropping when the pump is started. Remove restrictions and/or increase pipe size.
Pump will not turn—locked	Foreign matter in the pump	Clean out the pump—inspect the strainer screen.
	Bearing seized	Replace the pump’s bearings—grease bearing every three months, using a ball bearing grease.
	Moisture in the pump	Thaw and break loose carefully. Check with the product supplier if the product contains water. Properly remove the moisture from the product.
Pump will not build pressure	Poor suction conditions	Check the storage tank excess flow valve—clean filter screen. The suction pipe might be too small or restricted. Remove restrictions and/or increase pipe size.
	Bypass valve set too low	Set the valve for higher pressure (see valve’s instructions).
	Too much impeller clearance	Do a performance test on the pump (see preventive maintenance program).

Appendix G—Troubleshooting Guide (Continued)

Problem	Cause	What To Do
Noise or vibration in the pump	Cavitation from poor suction conditions	Make sure all valves are open, look for restrictions on the suction piping and clean the strainer screen.
	Coupling misaligned	Align the coupling.
	Coupling or coupling guard loose	Tighten the coupling and its guard.
	Coupling rubber insert worn or damaged	Replace the rubber insert and check coupling alignment.
	Worn bearings	Replace if necessary—lubricate every three months.
	Defective or wrong size bypass valve	Confirm the size of the bypass valve required for your application. Inspect, repair or replace the valve.
	Loose anchor bolts	Tighten all pump's anchor bolts.
Electric motor gets hot or overload protection kicks out	High differential pressure	Check the motor's full load amperage. Adjust the bypass valve setting to a lower setting. See recommendations for low capacity due to high differential pressure.
	Low line voltage	Check line voltage when in operation. Be sure motor is wired for the proper voltage. Check the electric motor's nameplate.
	Starter overload Heaters too small	Check the motor load with an ammeter and confirm the heater size with the starter's manufacturer.
	Motor shorted	Totally Enclosed Fan-Cooled electric motors (TEFC) and explosion proof electric motors are subject to moisture condensation inside when used intermittently. To eliminate moisture you might allow the motor to operate at least once a week until it get sufficiently hot to evaporate the moisture.
Leaks	Failed O-rings or mechanical seal assembly	Inspect and replace the seals and O-rings, if needed.

Appendix H—Extended Storage Procedures

If your Coro-Flo® pump is to be removed from service for some time, the pump must be protected, as propane, butane and anhydrous ammonia all leave the metal “bare” and open to corrosion. Piping and tanks not in service should also be protected, as the rust that forms can destroy the pump’s seals almost immediately after startup.

1. Fill or thoroughly flush the pump with a light rust-inhibiting oil. (If the pump is flushed with oil, placing some desiccant packets inside the pump will provide added protection.)
2. Plug all pump openings.
3. Store in a dry location.
4. Before placing the pump back into service, drain the oil and remove any desiccant packets.
5. Refer to “Operation of your Coro-Flo® pump” on page 7.



Corken, Inc. • A Unit of IDEX Corporation

3805 N.W. 36th St., Oklahoma City, OK 73112

Phone (405) 946-5576 • Fax (405) 948-7343

Visit our website at <http://www.corken.com>

or e-mail us at info.corken@idexcorp.com