

IMPORTANT INSTRUCTIONS

SSV MODEL VANE PUMPS

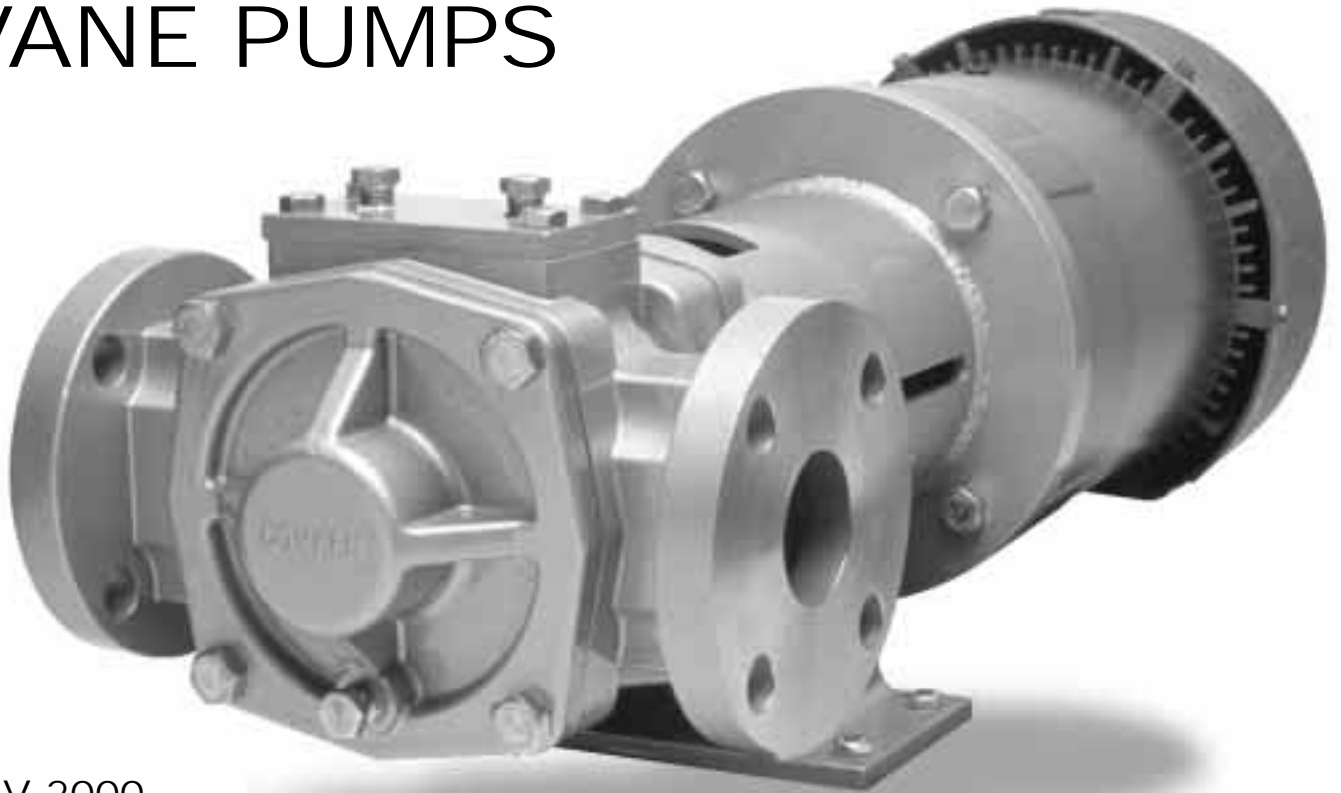

SSV 2000

Solutions beyond products...

CORKEN[®]
IDEX

Warning: (1) Periodic inspection and maintenance of Corken products is essential. (2) Inspection, maintenance and installation of Corken products must be made only by experienced, trained and qualified personnel. (3) Maintenance, use and installation of Corken products must comply with Corken instructions, applicable laws and safety standards (such as NFPA Pamphlet 58 for LP-Gas and ANSI K61. 1-1972 for Anhydrous Ammonia). (4) Transfer of toxic, dangerous, flammable or explosive substances using Corken products is at user's risk and equipment should be operated only by qualified personnel according to applicable laws and safety standards.

The Model and Serial Numbers are shown on the nameplate of the unit. Record this information for future reference.

Model No. _____

Serial No. _____

Date Purchased _____

Date Installed _____

Purchased From _____

Installed By _____

WARNING

Install, use and maintain this equipment according to Corken's instructions and all applicable federal, state, local laws and codes. Periodic inspection and maintenance is essential.

CONTACTING THE FACTORY

Before you contact the factory, note the Model Number and Serial Number of your pump. The Serial Number directs us to a file containing all information on material specifications and test data applying to your specific pump. When ordering parts, the Corken Service Manual should be consulted for the proper Part Numbers. ALWAYS INCLUDE THE MODEL NUMBER AND SERIAL NUMBER WHEN ORDERING PARTS.

TABLE OF CONTENTS

1.	INTRODUCTION TO THE SSV MODEL VANE PUMP	Page 4
2.	EXCLUSIVE FEATURES OF THE SSV MODEL VANE PUMP	Page 4
3.	MECHANICAL SPECIFICATIONS	Page 4
4.	MATERIAL SPECIFICATIONS.....	Page 5
5.	INSTALLATION OF THE SSV MODEL VANE PUMP	Page 6
6.	INLET PIPING RECOMMENDATIONS	Page 6
7.	OUTLET PIPING RECOMMENDATIONS.....	Page 6
8.	BY-PASS SYSTEM REQUIREMENTS.....	Page 6
9.	DRIVER INSTALLATION	Page 7
10.	MECHANICAL SEAL INSTALLATION	Page 8
11.	PUMP START-UP CHECKLIST	Page 8
12.	PREVENTATIVE MAINTENANCE	Page 8
13.	STORAGE	Page 8
14.	PARTS DETAIL DRAWING.....	Page 9
15.	DISASSEMBLY OF THE SSV MODEL VANE PUMP	Page 10
16.	REASSEMBLY OF THE SSV MODEL VANE PUMP	Page 12
17.	REVERSING OF PUMP ROTATION	Page 14
18.	TROUBLESHOOTING	Page 15
19.	ILLUSTRATED INSTALLATION TIPS	Page 16

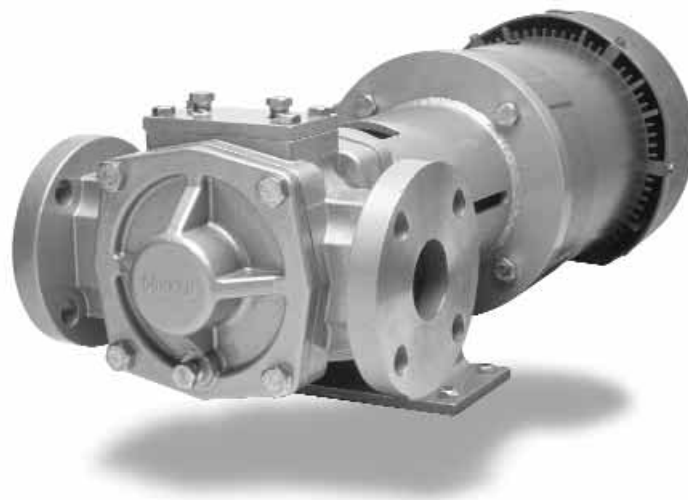

1. INTRODUCTION TO THE SSV MODEL VANE PUMP

The Corken SSV Model Vane Pump is a special type of rotary positive displacement pump, known as a sliding vane pump.

The sliding vane pump has many of the advantages of other rotary positive displacement pumps (i.e., gear pumps), plus the ability to compensate for wear and operate at a lower noise level especially when pumping light viscosity liquids and liquefied gases.

The sliding vane pump consists of a rotor turning in a cam (or liner) machined eccentrically in relation to the rotor; thereby displacing the liquid trapped between the rotor, cam, and blades (or vanes). The Corken SSV pumps are made with blades produced from advanced polymers which exhibit extremely low coefficients of friction. The blades are self-adjusting for wear which extends the life of the pump while maintaining its original efficiency.

2. EXCLUSIVE FEATURES OF THE SSV MODEL VANE PUMP

In addition to being especially suited for handling volatile liquids, the SSV pump has a number of features to help make it more easily operated and maintained.

- The SSV pump is primarily constructed of 316 stainless steel which enables it to be utilized in a wide range of applications.

- The SSV pump utilizes a mounting bracket so that it can be direct driven. This bracket eliminates time consuming alignment procedures and ensures proper alignment which helps to extend pump and seal life.

- The SSV incorporates a clean sweep design which allows for a low residual of liquid to remain in the pump between cycles. This reduces the potential for cross contamination when pumping multiple products.

- The SSV pump accepts most cartridge and component mechanical seals, which offers sealing flexibility when application requirements call for a specific type.

- Replaceable cam (or liner) and sideplates absorb wear and tear which saves potential costs of replacing expensive pump components such as casing.

- Direct motor speed capabilities of 1750 and 1150 RPM eliminate the need for costly speed reduction.

- The SSV's easy back pull-out design allows for servicing of the entire pumping chamber through removal of four bolts. This eliminates the need to disturb piping and driver when maintenance is required.

3. MECHANICAL SPECIFICATIONS

Specifications	SSV 2000	SSV 1500
Suction Flange	2" ANSI 150# FF	1.5" ANSI 150# FF
Discharge Flange	2" ANSI 150# FF	1.5" ANSI 150# FF
1750 RPM/Nominal Flow Rate/BHP*	60 GPM/3.5 BHP	35 GPM/2.9 BHP
1150 RPM/Nominal Flow Rate/BHP*	40 GPM/2.5 BHP	23 GPM/2.0 BHP
Minimum Temperature	-20° F	-20° F
Maximum Temperature	225° F	225° F
Maximum Working Pressure	400 psi	400 psi
Maximum Differential Pressure	100 psi	100 psi
Maximum Viscosity	100 SSU	100 SSU

*Flow and power at listed RPM is based on water at 50 psi differential.

4. SSV SERIES PUMPS MATERIAL SPECIFICATIONS

PART	MATERIAL	OPTIONAL
Case, Head	316 Stainless Steel	
Rotor Shaft		
Cam		
Sideplate, Bearing	Carbon Graphite	
Seal Faces	Silicon Carbide/Carbon	Other Options Available
Seal Metal Parts	316 Stainless Steel	
Blades, Blade Drivers	PEEK	
O-Rings	Viton®	Aflas, Kalrez, Teflon® Encapsulated Viton®, Ethylene Propylene

*Teflon is a registered trademark of Dupont.



SSV Nameplate

5. INSTALLATION OF THE SSV PUMP

The installation of a Vane Pump is a simple matter but the principles outlined in this manual must be followed exactly in order that the pump may give the performance you expect.

No pump can discharge more liquid than it receives so the pump location and the inlet piping must be given careful attention. If the inlet piping is inadequate to supply the demand of the pump you may expect trouble! It is recommended that the inlet piping diameter be 1 pipe size larger or at a minimum, no smaller than the inlet size of the pump.

The pump must be located as near the tank as possible.

Care should be taken to ensure that sufficient NPSH is provided to the SSV Pump. Although a Corken vane pump is known for its suction lift capabilities it is always recommended to provide a flooded suction with the supply tank above the pump whenever it is possible. Contact your local Corken representative for piping recommendations specific to your installation.

The foundation for the pump is important. The foundation must be firm and level and preferably of concrete. The suggestions on Figure 1 must be observed.

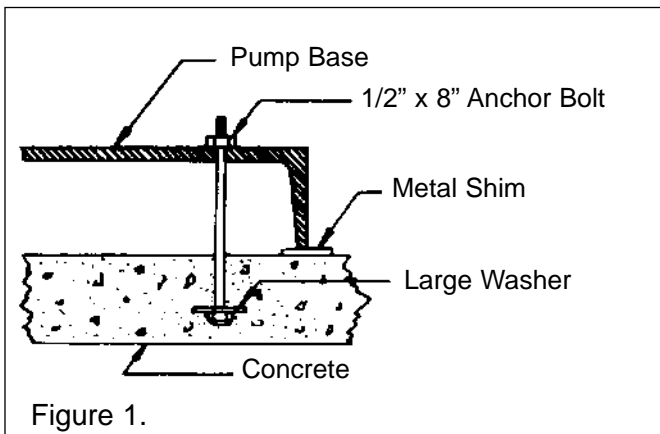

After the concrete has set, check the pump base for level. Drive metal shims under the base near anchor bolts as shown. Tighten anchor bolts and recheck the base for level.

6. INLET PIPING RECOMMENDATIONS

1. A strainer of the Y type with 30 to 40 mesh screen is recommended for the inlet line near the pump. (Mesh size indicates the number of openings per lineal inch).

2. Use flexible connections in the pump inlet and outlet piping to compensate for piping strains.

3. Use an eccentric swage at the pump inlet nozzle to change the line size (flat side up).

4. Make the inlet line level or slope it downward to the pump.

5. The tank shutoff valve should be a free flow type and not a standard globe valve.

7. OUTLET PIPING RECOMMENDATIONS

1. A pressure gauge should be installed in the discharge piping as close to the pump as possible. This pressure gauge will tell you the complete story of the operation inside your pump. Be sure you have one installed.

2. The outlet piping size should be chosen so that pressure build up related to restrictions is minimized. Although outlet piping is not as critical as the inlet, it is always wise to consider the pressure losses created by selecting certain piping and accessories. Your local Corken representative will be helpful in this analysis.

8. BYPASS SYSTEM REQUIREMENTS

1. A pump by-pass system must be installed. If the pump discharge is shut-off before the driver is stopped, dangerously high pressures can develop. A by-pass valve must be installed to permit the pump to discharge back to the supply tank, at a predetermined pressure.

2. The pump assembly may have an internal relief valve. This valve is intended to be used as a relief device not as an operational bypass valve. The internal relief valve limits the discharge pressure of the pump and routes the discharge directly back into the pumping chamber. During internal bypass heat is generated as the liquid recirculates within the pump. The pump can only be operated for a short period of time in this mode before high damaging temperatures are encountered.

3. Always install an external by-pass valve in the pump discharge line. The return piping may discharge into the tank at any convenient opening, either liquid or vapor, but it should not connect into the pump inlet piping system.

9. DRIVER INSTALLATION

When installing the pump driver follow these procedures.

1. Using a nitrile spider coupling, slide the 1" end of the coupling over the pump shaft. Do not tighten the set screw. Place the spider into the coupling end.
2. Slide the remaining coupling end over the motor shaft until flush with the end of the shaft.
3. Carefully slide the motor into the end of the mounting bracket while aligning the coupling and spider.
4. Align the bolt holes and install four 1/2" x 1" bolts through the mounting bracket into the motor. Torque to 25 ft. lb.
5. If the coupling ends are not fully engaged, slide both coupling halves equally toward the spider until full engagement of the spider is achieved.
6. Tighten the coupling set screws.

The wiring of your electric motor is extremely important and must be done by a competent electrical contractor. The following wire size chart indicates the minimum standards for wire sizes.

Improper motor wiring will cause expensive motor difficulties from low voltage. If you suspect you have low voltage, call your Power Company. Connecting your motor for the voltage you have available is important too. The motors furnished with the SSV Pumps are usually dual voltage, so you must be sure of the voltage your Power Company is supplying you. Your motor will be completely ruined if it is connected for the wrong voltage.

A humid climate can cause problems, particularly in explosion proof motor applications. The normal breathing of the motor, and alternating between being warm when running and being cool when stopped, often will cause moist air to be drawn into the motor housing. This moist air will condense, and may eventually add enough free water to the inside of the motor to cause it to fail. To prevent this, make a practice of running the motor and pump at least once a week on a bright, dry day for an hour or so (pump through the By-Pass System). In this period the motor will heat up and vaporize the condensed moisture, and drive it out of the motor. No motor manufacturer will guarantee an explosion proof or totally enclosed motor against damage from moisture.

Motor				(a) Recommended Wire Size, AWG Length of Run (Feet)		
HP	Motor Phase	Volts	Approx. Full Load Amperes	0-100	To 200	To 300
3	1	115	34.0	6	4	2
		230	17.0	12	8	8
	3	230	9.6	12	12	12
		460	4.8	12	12	12
5	1	115	56.0	4	1	1/0
		230	28.0	10	6	4
	3	230	15.2	12	12	10
		460	7.6	12	12	12
7-1/2	1	230	40.0	8	6	4
	3	230	22.0	10	10	8
		460	11.0	12	12	12
10	3	230	28.0	8	8	8
		460	14.0	12	12	12
15	3	230	42.0	6	6	6
		460	21.0	10	10	10

10. MECHANICAL SEAL INSTALLATION

To install a seal not provided by Corken, follow the disassembly and reassembly instructions on the pages 10-14 in conjunction with the seal manufacturers instructions.

11. PUMP STARTUP CHECKLIST

Important Note: When incorporating a new SSV Pump into an application that does not have a flooded suction and a dry prime must be pulled, please note that the SSV pump is capable of running dry for 45 seconds without experiencing damaging wear (due to the light oil applied at the factory). If the pump has not primed itself after 45 seconds, please turn the unit off and prime the pump manually.

The following steps must be performed at the initial operation of your pump.

1. Make sure that the proper mechanical seal is installed.
2. Verify the strainer screen is clean.
3. Check coupling to ensure proper installation.
4. Check motor for proper wiring and rotation.
5. Review the complete piping system to make certain the function of every valve and piece of equipment is clearly understood. Everyone operating this system must be properly trained in normal operating procedures and emergency procedures in event of a malfunction.
6. Slowly open the storage tank bottom shut-off valve (suction line to the pump). Immediately check the system for leaks.
7. Open any shut-off valves between the by-pass valve and the storage tank.
8. Make a note of all pressure gauge readings especially the pressure gauge located at the discharge of the pump. Start the pump and circulate the liquid through the by-pass system back to the storage tank.
9. Verify proper pump rotation direction.
10. Adjust by-pass valve to open at desired pressure not to exceed the maximum allowable differential of the SSV Pump.

11. If you have both an internal relief valve and an external by-pass valve in your discharge piping, the internal valve must be set higher than the external by pass setting.

12. After initial operation, recheck and clear the strainer screen of any trapped debris.

12. PREVENTATIVE MAINTENANCE

Your SSV Pump requires regular maintenance and care like all mechanical equipment. A neglected or improperly repaired pump will result in premature failure and/or create an unsafe condition. Maintenance should only be performed by a properly trained individual.

Pump Maintenance Schedule

	Daily	Monthly	3 Months
Inspect Drive Coupling			X
Clean Inlet Strainer		X	
Check for Leaks	X		
Inspect Fittings	X		

Normal wear parts are the mechanical shaft seal, bearings, blades, blade drivers and sideplates.

When it becomes necessary to repair your pump or remove it from the system you must be absolutely certain that all of the product being pumped is bled from the pump and connecting piping. Special care must be taken during the bleeddown process to avoid danger to personnel and property in the area. Bleeding a liquefied gas system too fast is a common mistake and may result in 'refrigerated' liquid being left in the pump and piping even though a pressure gauge shows no pressure. As the 'refrigerated' liquid begins to warm, more gas will escape causing a dangerous condition. Take your time in bleeding your system and make proper provisions to vent or capture the gas in accordance with local regulations. Only a properly trained individual should ever be allowed to bleed a pumping system.

13. STORAGE OF SSV VANE PUMPS

If your SSV Pump is to be removed from service for some time, it would be wise to plug the pump to ensure that no foreign material enters the pump while out of operation.

14. PARTS DETAIL DRAWING

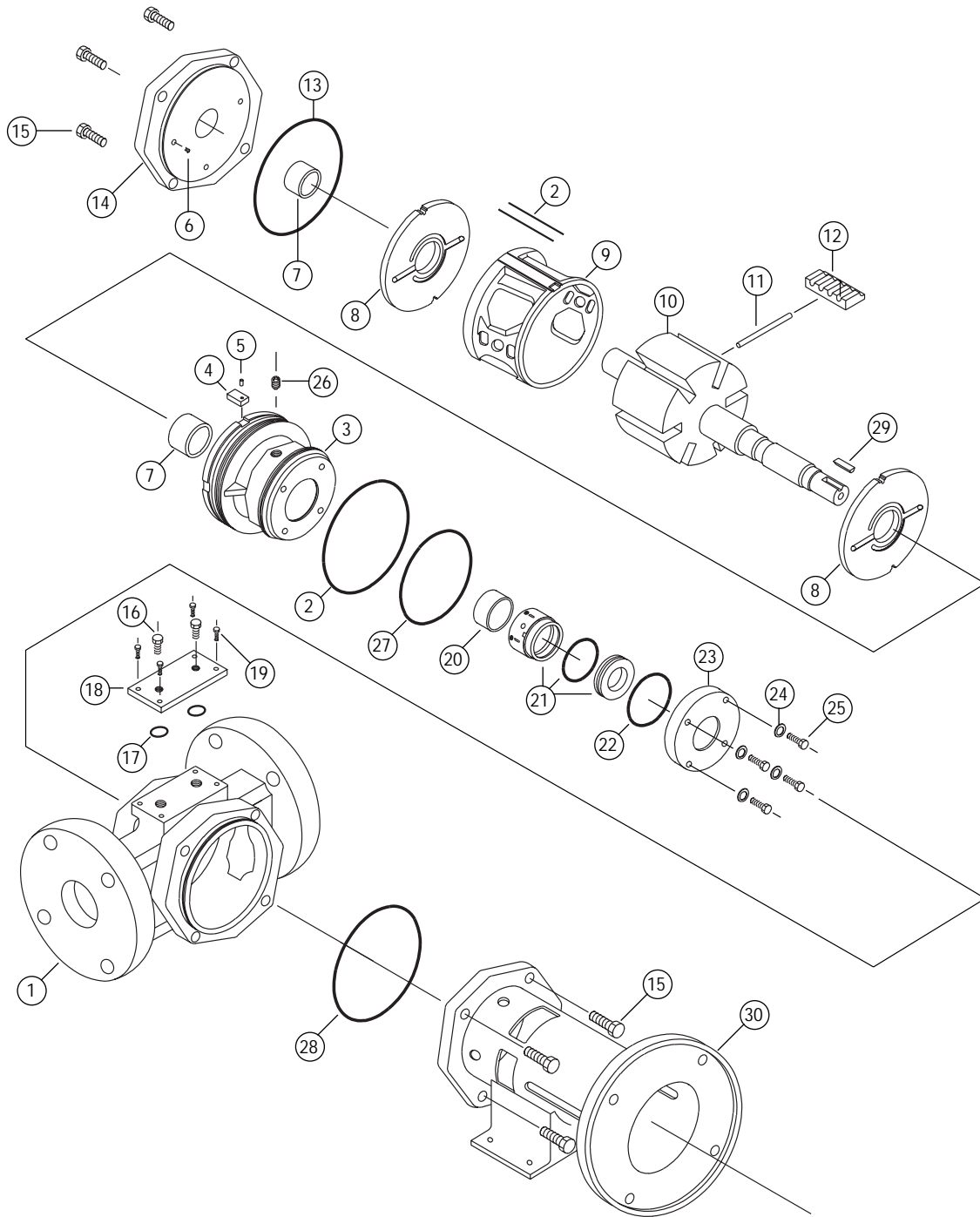

No	Part No.	Description	Qty
1	4951	Case	1
2	2-247	O-ring - Seal Head	2
3	4959	Seal Head	1
4	4960	Seal Head Key	1
5	4984	3/16 x 1/2 Roll Pin	2
6	7006-031NC025C	SOC HD Set 5/16-28 x 1/4"	2
7	4957	Sleeve Bushing	2
8	4954	Sideplate	2
9	4952	Cam	1
10	4953	Rotor-shaft	1
11	4956-X	Blade Driver	3
12	4955	Blade	6
13	2-255	O-ring - Access Head	1
14	4958	Access Head	1
15	7001-050NC100C	Bolt - Hex Head	8

No	Part No.	Description	Qty
16	4973	1/4" Pipe Plug	3
17	2-126	O-ring - RV Cover	2
18	4962	Relief Valve Cover	1
19	7001-037NC075C	Bolt - Hex Head	4
20	4975	Seal Spacer	1
21	4971-1XDAS	Type 8-1 Seal Assembly	1
22	2-226	O-Ring - Gland Plate (with Seal)	1
23	4969	Gland Plate	1
24	7201-037C	3/8 Flat Washer	4
25	7001-037NC100C	Bolt - Hex Head	4
26	4974	1/4" Flush Seal Pipe Plug	2
27	2-243	O-ring - Outer Seal Head	1
28	2-252	O-ring - Mounting Bracket	1
29	4244	Shaft Key	1
30	4961	C-Face Mounting Bracket	1

15. DISASSEMBLY INSTRUCTIONS FOR THE SSV SERIES PUMPS

General Instructions:

Before attempting any pump disassembly, relieve pump, jacket, and seal system pressures and drain in accordance with applicable Federal, State, and local codes. Be certain all protective clothing is worn, if required.

Pump Assembly Removal:

1. Before the pump can be disassembled, any external fittings in the seal gland plate must be removed.

2. Remove the blind head bolts.

3. Using a pry bar, gently pry between the face of the gland plate and the top of the mounting bracket.

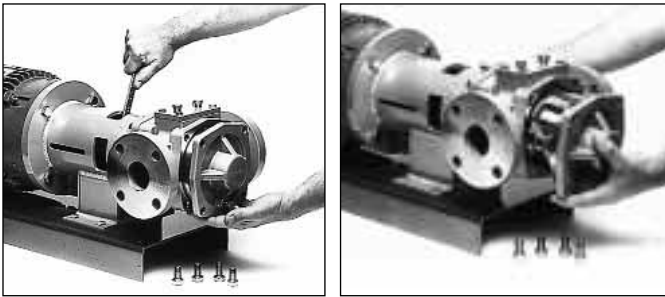

4. Support the blind head and cam with one hand while guiding the shaft end of the pump assembly with the other hand.

5. Pull the pump assembly through the case and place on workbench with the blind head facing down.



6. Mark the location of the pump shaft coupling and remove with pump shaft key.



Cartridge Seal Removal:

1. Replace original seal spacer tabs into the drive collar. Loosen the drive collar set screws.



2. Remove the gland plate bolts and washers.

3. Remove the cartridge seal assembly over the shaft.



Type 8-1 Seal Assembly Removal:

1. Remove the 1/4 inch flush seal plugs from the seal head.

2. Rotate the shaft to align the seal set screws to each of the 1/4 inch NPT ports.

3. Loosen all set screws in the seal body.



4. Remove the gland plate bolts and washers.

5. Carefully remove the gland plate from the seal head.

6. Lift the seal head away from the cam and sideplate and remove the seal assembly from the seal head.



7. Tap the seal seat out of the gland plate with a small screwdriver and hammer if seal replacement is required.

8. Remove the seal spacer from the rotor-shaft.

Pump Component Removal:

1. After removal of the seal head from the pump assembly previously outlined, inspect the sleeve bearing for excessive wear.

2. Remove and inspect the sideplate for damage.



3. Vertically remove the rotor-shaft and inspect for unusual wear.



4. Remove and inspect the blade drivers from the rotor-shaft. Inspect for mushroomed ends or external gouging.



5. Remove and inspect the cam for uneven wear.



6. Remove the blades and inspect for uneven blade tip wear.

7. Remove and inspect the remaining sideplate.

8. Inspect the sleeve bearing in the blind head for excessive wear.

Bearing Removal:

1. Press the seal head sleeve bearing out of the seal head.

2. Chip out a section of the bearing in the blind head with a hammer and small screwdriver. Take care not to scar the bearing bore in the head.

3. Remove the remaining sleeve bearing pieces.

4. Clean both bearing bores.

16. REASSEMBLY INSTRUCTIONS FOR THE SSV PUMP

General Instructions:

Lubricate all threads and pilot diameters with a high quality anti-seize compound such as Loctite Nickel Anti-Seize Lubricant 771®. Lubricate all new o-rings with a lubricant which will be compatible with the process fluid. Discard all used o-rings and components which exhibited severe wear. The following instructions assume all wear components have been replaced. If your wear components do not exhibit extreme wear, replace into pump assembly per these instructions except for the sleeve bearings. If your sleeve bearings are in good condition, skip directly to Pump Reassembly.

Bearing Installation:

1. Place the blind head nose down on the workbench.



2. Press in the sleeve bearing until it is flush with the top surface of the blind head.

3. Repeat for the seal head.



Pump Reassembly:

1. Place the blind head nose down on the workbench again with the drain tap oriented towards you. Stabilize the head with blocks to allow building the complete pump on this head.

2. If the direction of rotation of the pump is to be reversed, remove the 5/16 X 1/4 inch set screw and replace in the opposite port in each head.



3. Place a new head o-ring onto the pilot diameter of the blind head assembly.

4. Align one sideplate onto the blind head pilot diameter. Orient the sideplate such that the key slot is vertical and the C faced groove opens toward the pump inlet. Ensure that the holes in the sideplate are located directly over each port in the head.



5. Install three blade drivers into the rotor-shaft assembly while holding vertically with the short end down. Install the short end of the rotor-shaft through the sideplate and into the blind head.

6. Place the cam with the wide end down over the rotor-shaft assembly. Orient the cam alignment pin to the sideplate key slot notch with the key slot on the outer diameter of the small end away from you.

7. Install the blades with the curved end toward the cam and the slots facing in the direction of rotation.



8. Place the other sideplate onto the cam facing exactly opposite the first sideplate. Again, orient the sideplate such that the key slot is vertical and the C faced groove opens toward the pump inlet.



9. Line up the key slot to the key slot in the cam.

10. Install the seal head nose up over the shaft on top of the last sideplate. Orient the key through the sideplate and into the key slot in the cam.



11. Lubricate the shaft to facilitate easy installation of the mechanical seal.

Mechanical Seal Installation:

Type 8-I (4971-1X) Seal:

1. Lubricate the outer o-ring of the seal seat and press into the gland plate by hand with the shiny side facing outward.



2. Install the seal spacer chamfered side down over the shaft.



3. Install the seal body with the seal face up until the seal body contacts the seal spacer.



4. Lubricate both seal faces with light oil.

5. Install the gland plate assembly to the end of the seal head assembly.

6. Install four 3/8 x 1 inch bolts and 3/8 inch flat washers. Torque in a crossing pattern to 15 ft-lb.

7. Tighten the mechanical seal set screws with an Allen wrench by reaching through the two tapped ports in the end of the seal head. The rotor-shaft can be easily turned by hand to align the set screws to the ports. **Caution:** Assume that all set screws in the mechanical seal are loose. Loose screws can cause premature seal and pump damage.



Cartridge Seal:

1. Install the cartridge seal over the shaft onto the seal head.
2. Install four 3/8 x 1 inch bolts and 3/8 inch flat washers and torque in a crossing pattern to 15 ft-lb.
3. Tighten the outer set screws to lock the seal drive collar to the shaft. Remove and save the spacer tabs.

Pump Assembly Continued:

1. Install the shaft key on the shaft.
2. Install the 1/4 inch flush-seal plugs into the seal head.
3. Install the seal head and outer seal head o-rings onto the seal head.
4. Install the pump shaft coupling to align back to the mark made during disassembly.
5. While supporting the pump assembly horizontally with both hands, slide the pump assembly into the case with the seal head key towards the top of the case.
6. After the cam has reached into the case, use one hand to guide the shaft through the mounting bracket. Minor twisting of the cam may be required to align the seal head key to the slot in the case.

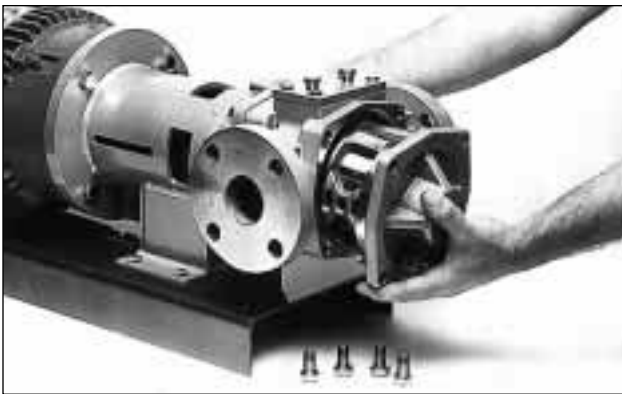

7. Remove the blind head and rotate the shaft to align the coupling halves. Push on the shaft to fully engage the coupling and spider.
9. Reinstall the blind head with the drain plug at the bottom.
10. Install the four 1/2 X 1 inch bolts through the blind head into the case and torque in a crossing pattern to 25 ft.-lb.

11. Install the 1/4 inch hex head pipe plug into the drain tap in the blind head.

12. Reinstall all external fittings back into the seal gland plate if applicable.

13. If the direction of rotation was reversed, remove the two self tapping nameplate screws and reorient the nameplate such that the large arrow points in the correct direction of rotation. The motor rotation must also be reversed per manufacturer's instructions.

17. REVERSING OF PUMP ROTATION

To reverse rotation and operation of your pump, five tasks must be performed.

1. All blades must be turned to face in the opposite direction, curved portion of blade still nearest to the cam.
2. Flush plugs in both heads must be moved to opposite side.
3. Sideplates must be rotated 180° (not flipped over).
4. Motor wiring must be reversed.
5. Reorient the nameplate such that the large arrow indicates the correct direction of rotation.

18. TROUBLESHOOTERS GUIDE FOR CORKEN CORO-VANE PUMPS

In diagnosing pump and system troubles, the following information is essential:

1. Pressure at pump suction.
2. Pressure at pump discharge.
3. Pressure in tank being evacuated.
4. Pressure in tank being filled.
5. Pipe size and length of suction and discharge lines.
6. Size and length of vapor equalizing line.

PROBLEM	CAUSE	WHAT TO DO
Low capacity	Pump speed too slow	Check motor speed. Consult pump performance curve.
	Low voltage	
	High differential pressure	Restriction in discharge piping or discharge piping hose too small or not used.
	By-pass valve stuck open or set too low	Check capacity with by-pass line closed with manual valve. <u>Use care:</u> Readjust, repair or replace valve.
	Clogged strainer	Clean strainer.
	Suction pipe too small or restricted	Indicated by pump inlet pressure dropping several pounds when pump is started. Remove restriction or modify piping.
	Worn blades	Replace blades.
	Worn sideplates	Replace sideplates.
Pump runs but no flow	Valve closed	Open valve.
	Broken shaft	Disassemble and inspect pump. Repair if necessary.
Pump won't turn—locked	Foreign matter in pump	Clean out the pump—install strainer on suction line.
	Blades broken	Clean out pump carefully and replace blades.
	Bearing seized	Inspect for additional damage. Replace bearing and other parts as needed.
	Moisture frozen in pump	Thaw and break loose carefully. (Do not use an open flame to thaw.)
Won't build pressure	Poor suction conditions	Increase pipe size. Clean inlet strainer.
	By-pass valve set too low	Set valve for higher pressure (see instructions).

PROBLEM	CAUSE	WHAT TO DO
	Worn blades, sideplates	Disassemble, inspect and repair if necessary.
Pump is noisy	Cavitation from poor suction conditions	As above.
	Bearings bad	Replace if necessary.
	Very high differential pressure	Check for restriction in discharge line.
Pump leaks around shaft	Seal or o-rings failed	Inspect seal assembly and replace if necessary. Keep new seal very clean and oil o-rings.
Motor gets hot or switch overload kicks out	Motor overloaded	Check motor load with ammeter. Differential pressure too high. Set by-pass lower—check for low line voltage at motor while pump is operating. Be sure motor is wired for proper voltage. Consult motor name-plate and wiring diagram.
	Starter overload heaters too small	Check motor load with ammeter and confirm heater size with starter manufacturer's instructions.
	Motor shorted out	TEFC (totally enclosed) and explosion proof motors are subject to moisture condensation inside when used intermittently. To eliminate trouble, allow motor to operate at least once a week long enough for motor to get hot. This would not be necessary during off seasons when equipment is not normally operating.

19. ILLUSTRATED INSTALLATION TIPS

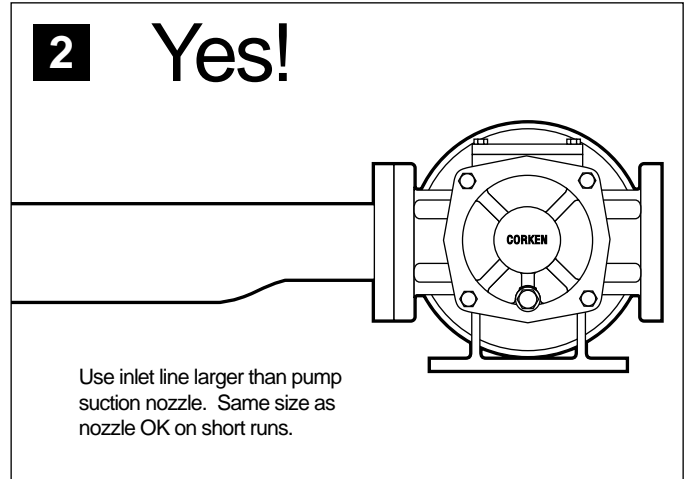
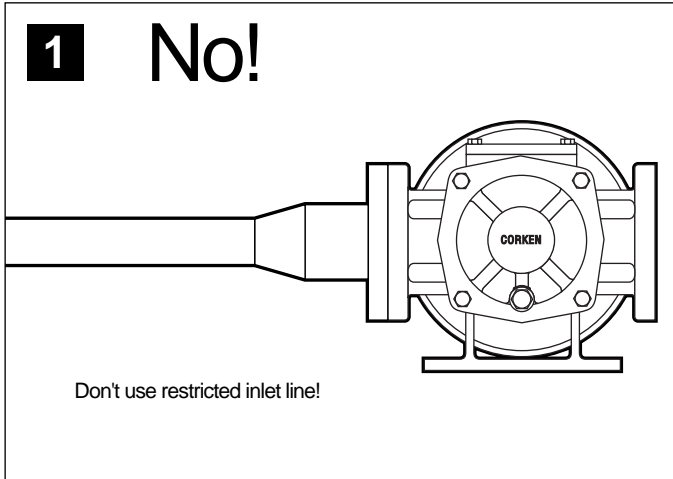

Pressure drop caused by restriction in suction line will cause vaporization and cavitation.

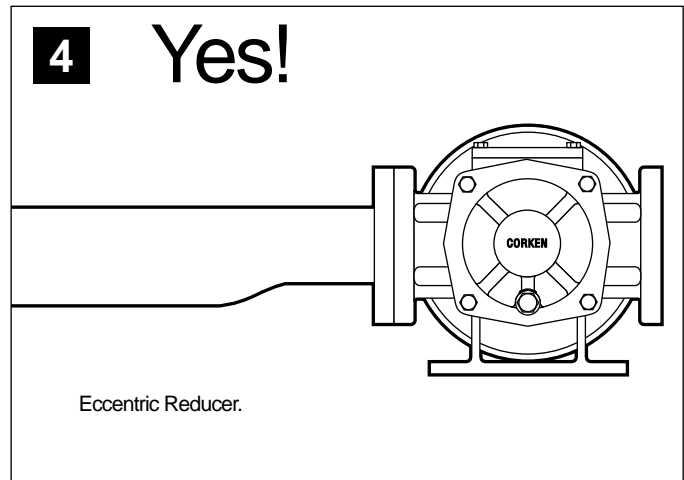
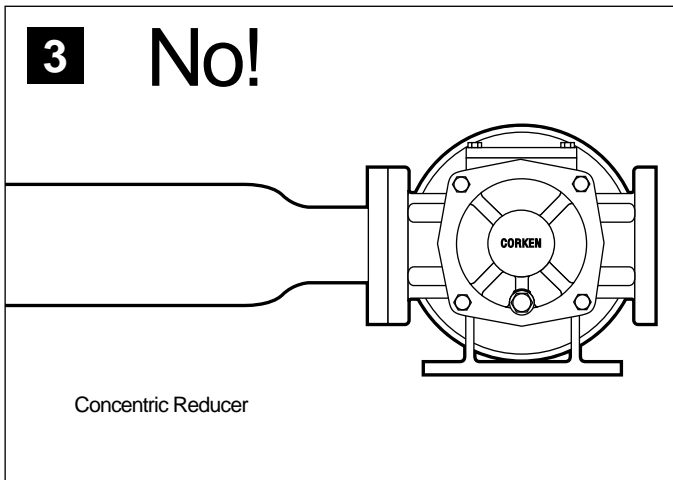

An eccentric reducer should always be used when reducing into any pump inlet where vapor might be encountered in the pumpage. The flat upper portion of the reducer prevents an accumulation of vapor that could interfere with pumping action.

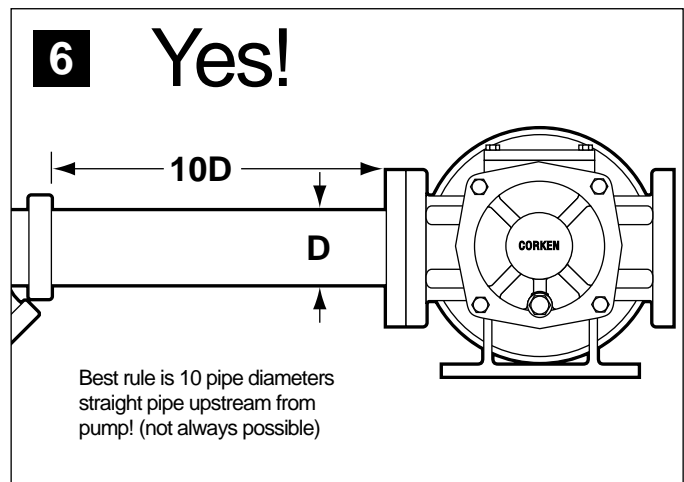
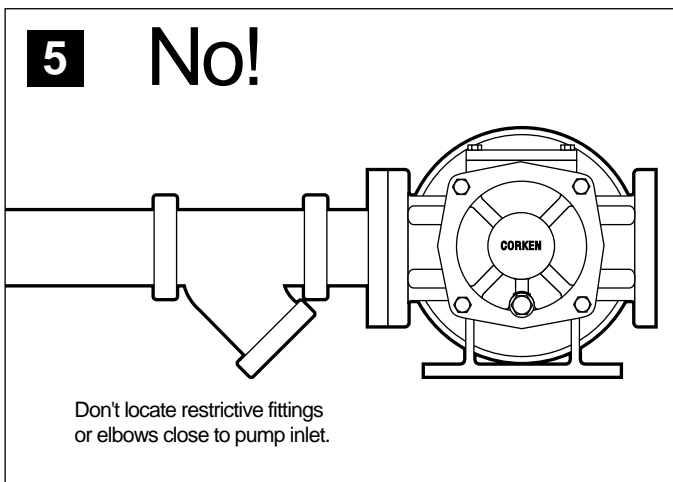

Turbulence caused by flow interference close to the pump accentuates incipient cavitation.

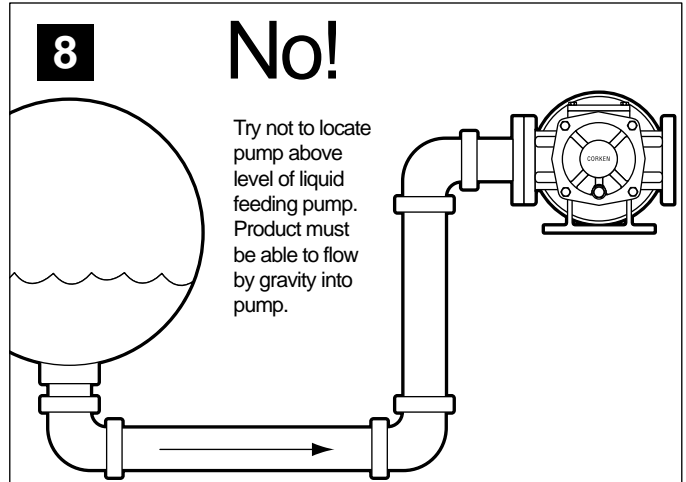
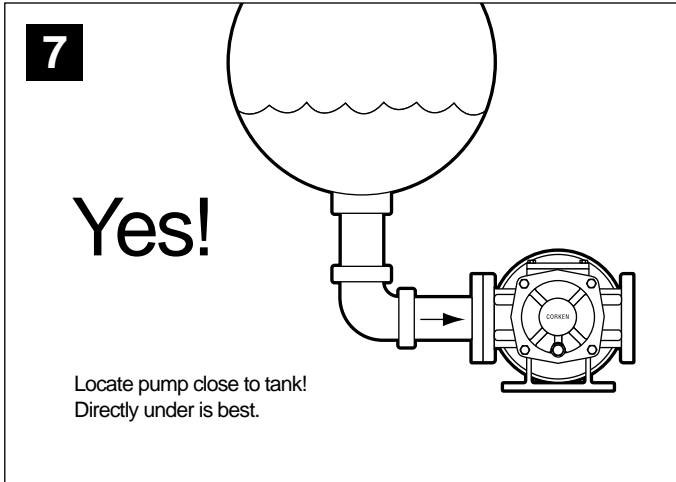

When possible, it is best to allow the pump to be fed by gravity flow to give stable, trouble-free operation.

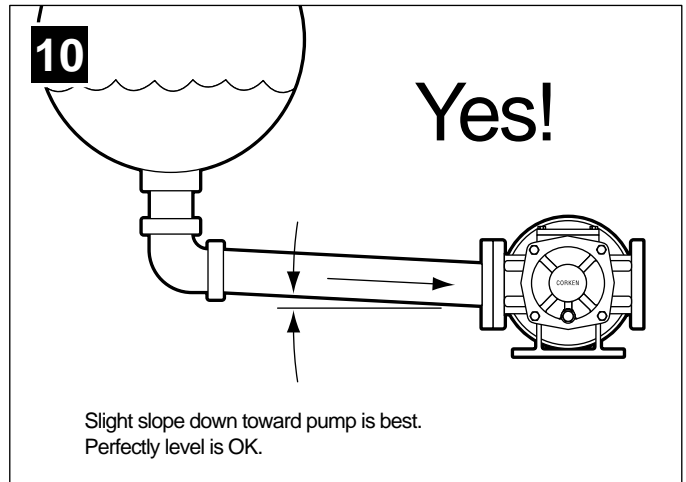
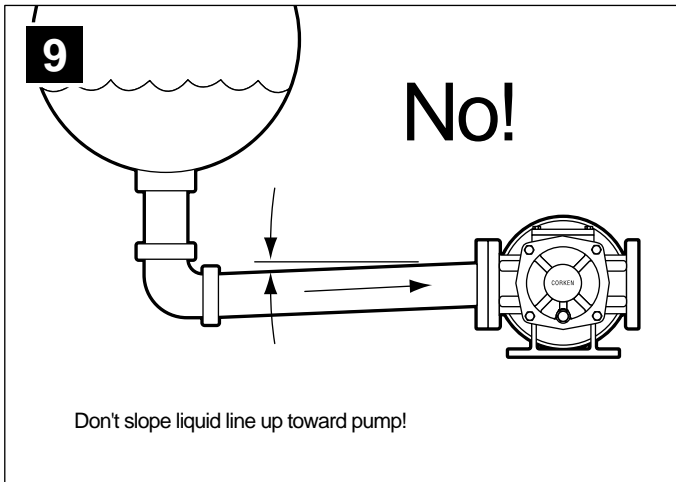

Vaporization in the pump inlet line can displace liquid in the pump so that pump may start up in a dry condition. A slope back toward the tank of only an inch or two in a 10 foot run will allow vapor to gravitate back into the tank and be replaced with liquid.

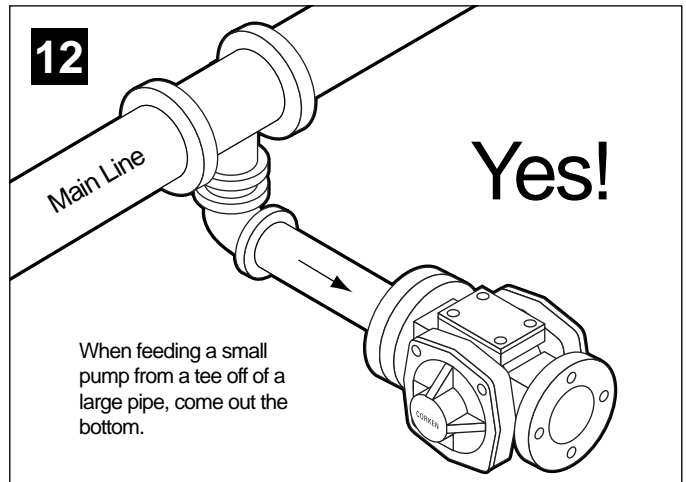
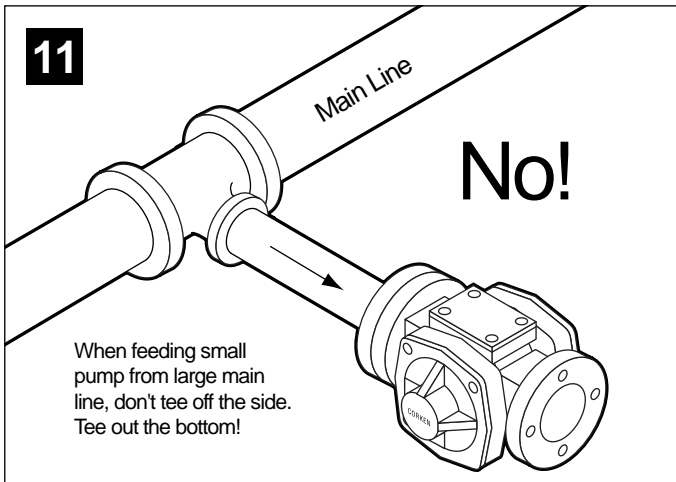

13

Good...

Multiple pumps fed from same main line.

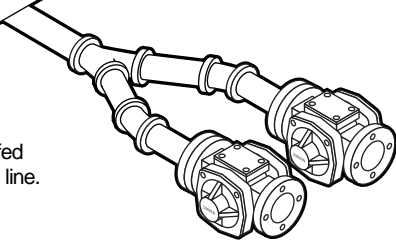

14

OK...

Pumps operating in parallel.

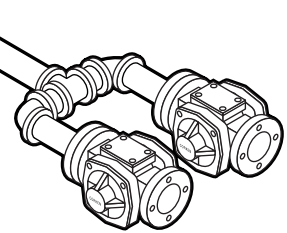

15

Best...

Parallel piping of SSV pumps.

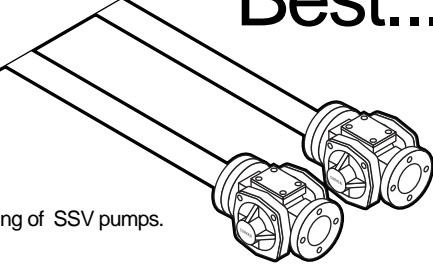

16

Bad...

Pump No. 1 is starved because of venturi action at tee. This would be acceptable for installations where both pumps would never operate at the same time.

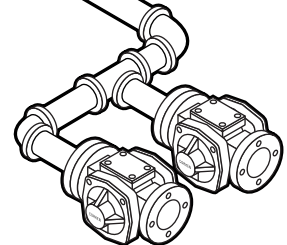

17

No!

Don't pipe bypass line back into suction piping! Heat buildup in recirculated products causes flashing of liquid to vapor with

immediate cavitation and ultimate dry-running. This is why the bypass relief valves which are built into many positive displacement pumps should not be used for normal bypass action when handling liquefied gases. The internal valve should be considered to be a back-up safety relief in addition to a back-to-tank bypass valve and should be set to relieve at a pressure 10 to 20 psi higher than the working bypass. Some built-in bypass valves have the capability of being piped back-to-tank so check with the pump manufacturer.

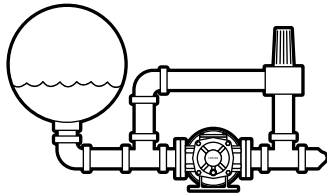

18

Yes!

Always pipe bypass back to tank! Make sure bypass line is large enough to handle full pump flow without excessive pressure build-up. High pressure rise can cause bypass valve to chatter and vibrate.

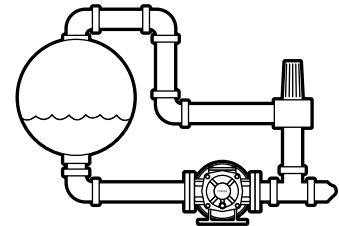

Solutions beyond products...

CORKEN[®]
IDEX

P.O. Box 12338, Oklahoma City, OK 73157
3805 N.W. 36th St., Oklahoma City, OK 73112
Phone (405) 946-5576 • Fax (405) 948-7343
E-mail corken@corken.com
Web address www.corken.com