

**Corken Specialty
Selection Guide**

Foam Blowing Agent Handling

CORKEN[®]
IDEX

Corken, a tradition of excellence

As a unit of IDEX Corporation, Corken Inc. is a leader in specialized niche markets. To maintain our leadership in your industry requires continual Innovation, Diversity and Excellence.

With over 50 years global experience in liquefied gas handling, Corken offers innovative solutions to the rapidly changing pumping needs of the Polyurethane industry. Corken's exceptional reputation is built upon decades of maintaining the highest quality and customer service standards.

Through intimate contact within your industry, Corken is committed to application of new product technology and streamlining product selection.

This specialized information packet is designed as a comprehensive guide to applying Corken products in your industry.

Solutions beyond products...
CORKEN
IDEX

Corken Meets the Challenges of Blowing Agent Handling

HIGH PUMPING PRESSURE

Corken's SC-Series multistage pump delivers higher differential pressures for current and future high vapor pressure product.

LOW NPSH

Corken products exceed expectations where NPSH is as low as 1 foot.

TEMPERATURE VARIATIONS

Corken products perform year around regardless of seasonal temperature variations.

MAINTENANCE PROBLEMS

Corken's unique design minimizes maintenance. Reduced operating speed and free floating impellers (no metal to metal contact) provide years of trouble free performance.

ENTRAINED GASES / VAPOR LOCK

Corken pumps perform with up to 50% entrained gas content eliminating lost time venting and re-priming.

SEALING INTEGRITY

Whether your application calls for mechanical sealing or sealless designs, Corken provides the widest range of options.

COMPREHENSIVE PUMP SELECTION

At Corken, we understand the value of time and commit ourselves to streamlining the process from pump selection through successful startup.

COMMITMENT AND SUPPORT

Corken products are backed by the strongest service commitment in your industry. We are pleased to provide you with our growing list of satisfied customers successfully handling the widest range of Fluorocarbons, Hydrocarbons, CO₂ and other similar liquefied gases.

A Comprehensive Guide to Blowing Agent Pumping

GUIDE TO PUMP SELECTION	7
Corken offers a wide range of products. This table identifies the pumping principle best suited to your flow and pressure requirements.	
SIDE-CHANNEL PUMP SERIES	8
Where high-differential pressures or problematic suction conditions are encountered the Side Channel pump provides a new dimension in liquid transfer.	
Principle of Operation	9
Performance Curves	10
Material Specifications	18
Dimensional Drawings	19
Spare Parts with Exploded View	21
CORO-FLO TURBINE SERIES	23
For low-capacity, medium-head pumping, the Coro-Flo Turbine is the pump of choice.	
Performance Curves	24
Material Specifications	26
Dimensional Drawings	27
Duplex Unit	30
Spare Parts with Exploded View	31
Technical Service Manual (Coro Flo)	33
Technical Service Manual (Seal Replacement)	41
BULK TRANSFER OF BLOWING AGENTS	45
LIQUID LIST	46
BLANK APPLICATION DATA SHEET	47
SYSTEM PIPING RECOMMENDATIONS	49
BY PASS VALVE / CORKEN MODEL B-166	58
WARRANTY INFORMATION	60
CONVERSION FACTORS	62

Guide to Pump Selection

FLOW VS. PRESSURE

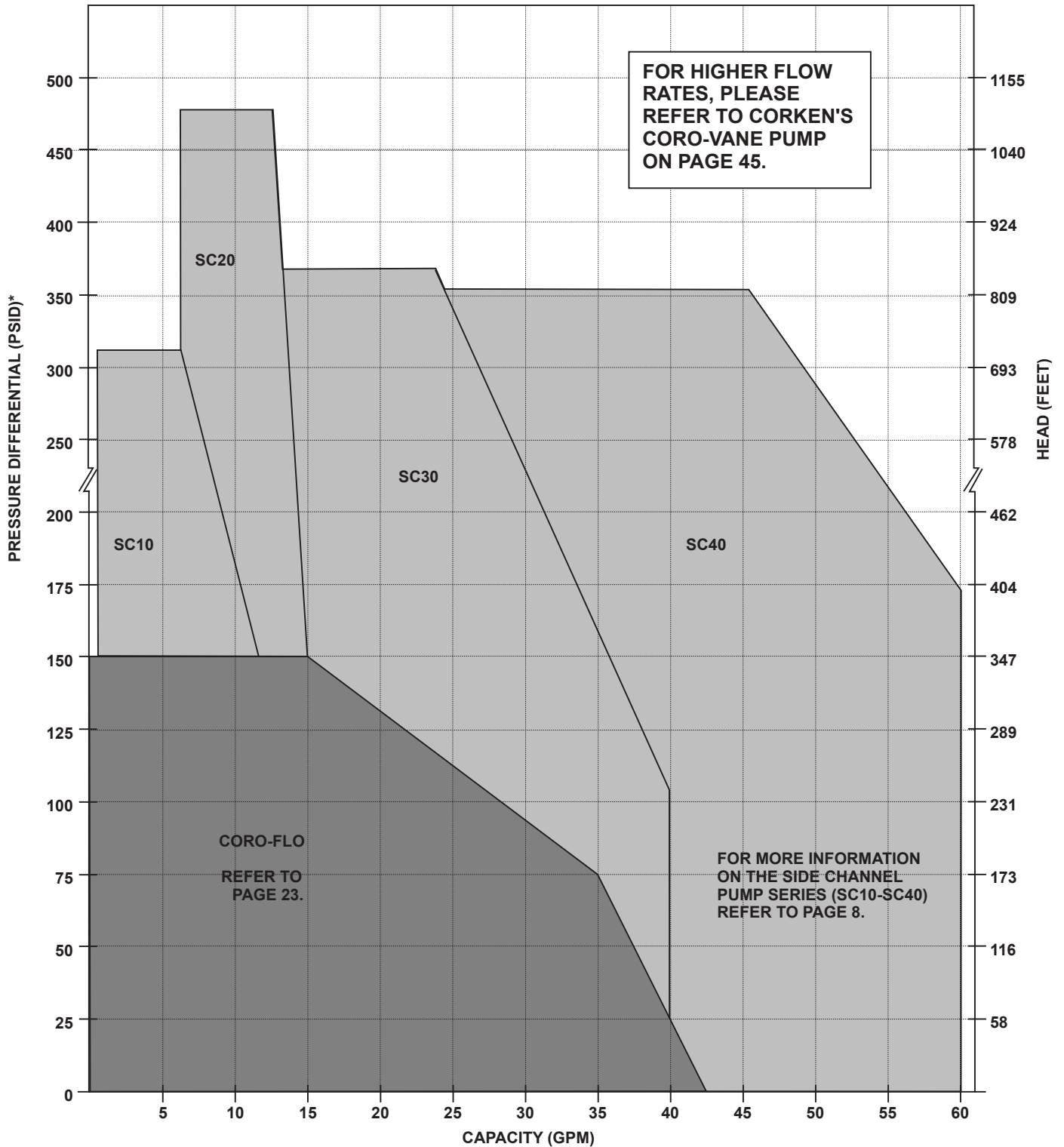

Please Note: Performance data is for reference only. Product limitations are listed in Specifications. Above pressure differential values are based on water (1.0 sg). Higher differential pressures may be attainable dependent upon the specific gravity of the liquid being handled. Consult factory for further details.

Side Channel Pump Series

SC SERIES SIDE CHANNEL PUMPS

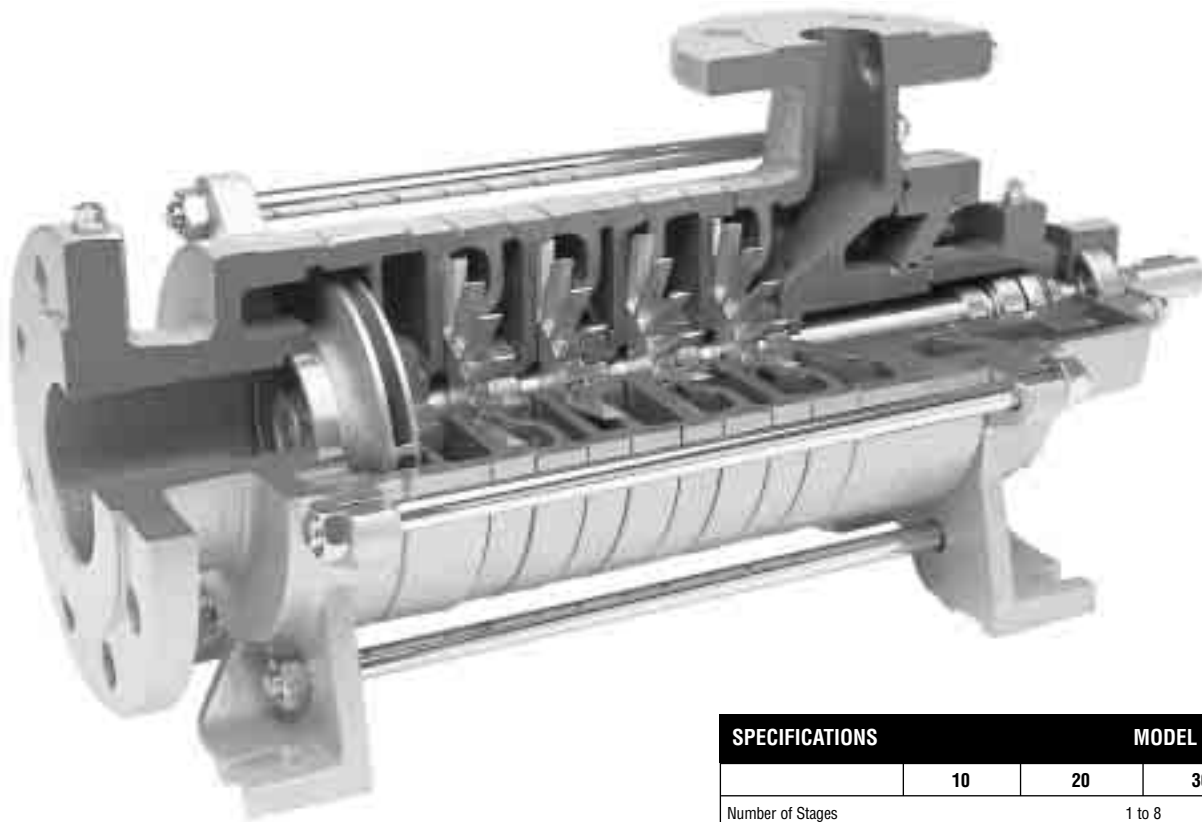

The latest generation of Blowing Agents create unique pumping challenges. Increasingly, differential pressures are rising and NPSH requirements are more demanding. Corken's SC series is designed specifically to overcome these obstacles and provide flexibility to meet future demands.

In winter months when peak differential pressures are encountered Corken's SC series eliminates the need to push existing technology beyond its design capability. Demands that are extreme for many pump designs fall into the heart of the SC series, simply put the right pump for your changing needs.

SPECIFICATIONS	MODEL			
	10	20	30	40
Number of Stages	1 to 8			
Inlet Flange Inches (MM)	1-1/2 (40)	2-1/2 (65)	2-1/2 (65)	3 (80)
Outlet Flange Inches (MM)	3/4 (20)	1-1/4 (32)	1-1/4 (32)	1-1/2 (40)
RPM-50 Hz RPM-60 Hz	1450 1150/1750	1450 1150/1750	1450 1150/1750	1450 1150/1750
Maximum Working Pressure PSIG (Bar)	580 (40)	580 (40)	580 (40)	580 (40)
Differential Pressure* Range PSI (Bar)	13 (.9) -375 (26)	13 (.9) -565 (39)	7 (.5) -440 (30)	13 (.9) -429 (29.5)
Min. Temp. °F (°C)	-40° (-40°)	-40° (-40°)	-40° (-40°)	-40° (-40°)
Max. Temp. °F (°C)	428° (220°)	428° (220°)	428° (220°)	428° (220°)
NPSH Range FT (M)	1.0 (.3) 13 (4)	1.3 (.4) 3.3 (1)	1.0 (.3) 6.6 (2)	1.0 (.3) 8.2 (2.5)
Maximum Viscosity SSU (CST)	1050 (230)	1050 (230)	1050 (230)	1050 (230)
Maximum Proportion of Gas Allowable	50%	50%	50%	50%
DIN Flange Option	Yes	Yes	Yes	Yes
ANSI Flange Option	CF**	Yes	Yes	Yes
Casing Material Option	Ductile Iron, Cast Iron, Stainless Steel			
Impeller Material Option	Bronze, Steel, Stainless Steel			
O-Ring Material Option	Neoprene, Viton®, Teflon®, Ethylene-Propylene			
Double Seal Option	Yes	Yes	Yes	Yes
Magnetic Drive Option	Yes	Yes	Yes	Yes
High Temp. Option	Yes	Yes	Yes	Yes
Internal Relief Option	No	No	No	No

* Above differential pressures are based on a 1.2 specific gravity.

** Consult Factory

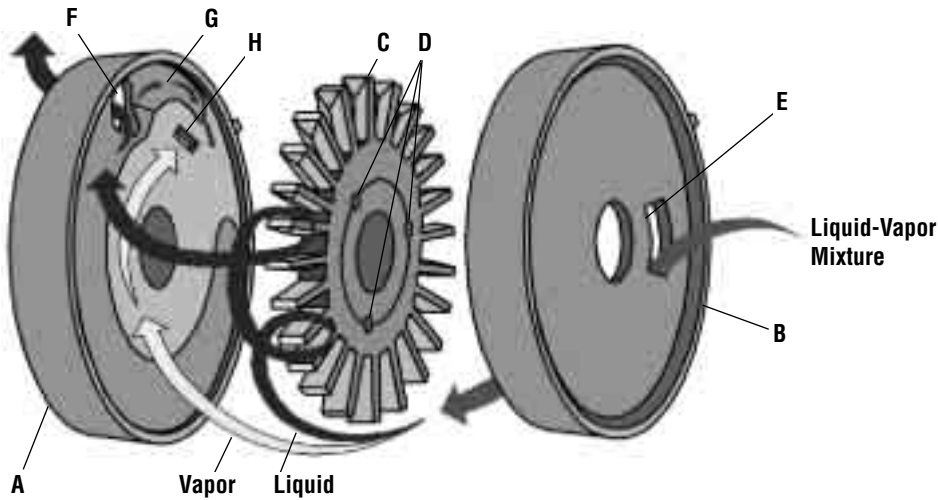

Item	Description
A	Discharge Stage Casing
B	Suction Stage Casing
C	Impeller
D	Equalization Holes
E	Inlet Port
F	Outlet Port
G	Mini-Channel
H	Secondary Discharge Port

PRINCIPLE OF SIDE-CHANNEL OPERATION

The design of the side-channel pump allows for the transfer of liquid-gas mixtures with up to 50% vapor; therefore eliminating possible air or vapor locking that can occur in other pump designs. A special suction impeller lowers the NPSH requirement for the pump.

The side-channel pump design is similar to a regenerative turbine in that the impeller makes regenerative passes through the liquid. However, the actual design of the impeller and casing as well as the principles of operation differ greatly. The side-channel pump has a channel only in the discharge stage casing (A) and a flat surface which is flush with the impeller on the suction stage casing (B). A star-shaped impeller (C) is keyed to the shaft and is axially balanced through equalization holes (D) in the hub of the impeller.

The liquid or liquid/vapor mixture enters each stage of the pump through the inlet port (E). Once the pump is initially filled with liquid, the pump will provide a siphoning effect at the inlet port. The effect is similar to what happens in water ring pumps. The water remaining in the pump casing forms a type of water ring with a free surface. A venturi effect is created by the rotation of the impeller and the free surface of the water, thus pulling the liquid into the casing.

After the liquid is pulled through the inlet port, it is forced to the outer periphery of the impeller blade by centrifugal action. It is through this centrifugal action that the liquid is accelerated and forced into the side channel. The liquid then flows along the semicircular contour of the side channel from the outermost point to the innermost point until once again it is accelerated by the impeller blade. The liquid moves several times between the impeller and the side channel. Thus the rotating impeller makes several regenerative passes until the liquid reaches the outlet port. The speed of the impeller along with the centrifugal action impart energy to the liquid through the exchange of momentum, thus allowing the pump to build pressure.

The side channel leads directly to the outlet port (F). At the outlet port, the main channel ends and a smaller minichannel (G) begins. At the point where the mini-channel ends, there is a small secondary discharge port (H) level with the base of the impeller blades.

As the liquid is forced to the periphery through centrifugal action due to its density, the vapor within the liquid stream tends to remain at the base of the impeller blades since it has a much lower density. The main portion of liquid and possibly some vapor, depending on the mix, is discharged through the outlet port. A small portion of the liquid flow follows the mini-channel and eventually is forced into the area between the impeller blades. The remaining vapor which was not drawn through the outlet port resides at the base of the impeller blades. At the end of the minichannel, as the liquid is forced into the area between the blades, the area between and around the impeller blade is reduced. The liquid between the blades displaces and thus compresses the remaining vapor at the base of the impeller blades. The compressed vapor is then forced through the secondary discharge port where it combines with the liquid discharged through the outlet port as it is pulled into the next stage or discharged from the pump. Thus entrained vapor is moved through each stage of the pump.

Each subsequent stage operates under the same principle. The number of stages can be varied to meet the required discharge head. When multiple stages are required, the relative positions of the stage outlet ports are radially staggered to balance shaft loads.

Performance Curves

SC10 SERIES 1150 RPM

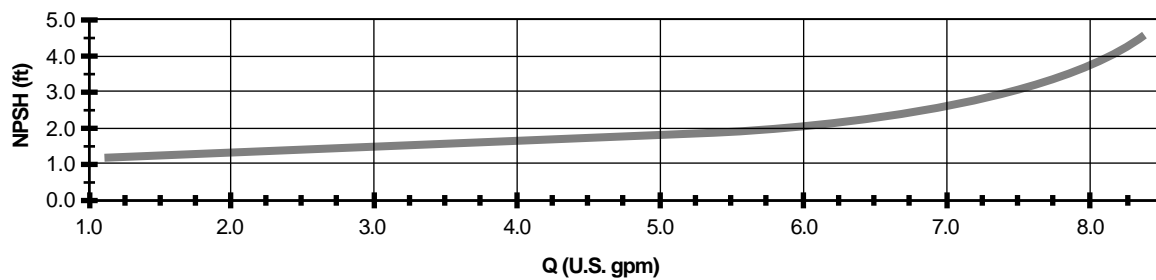
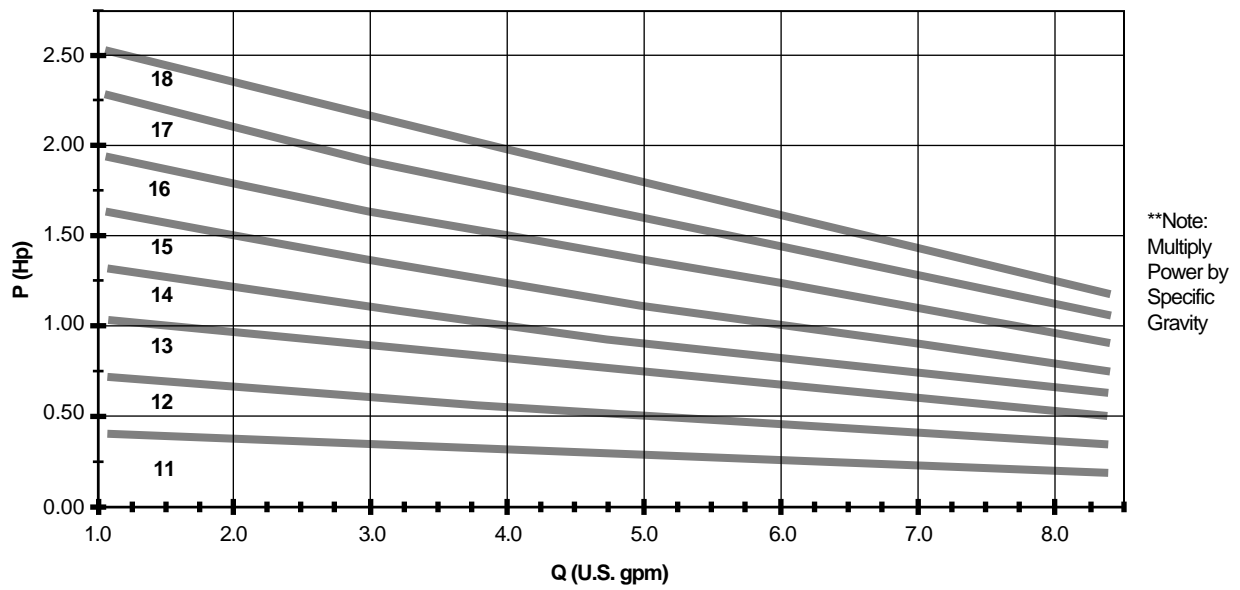
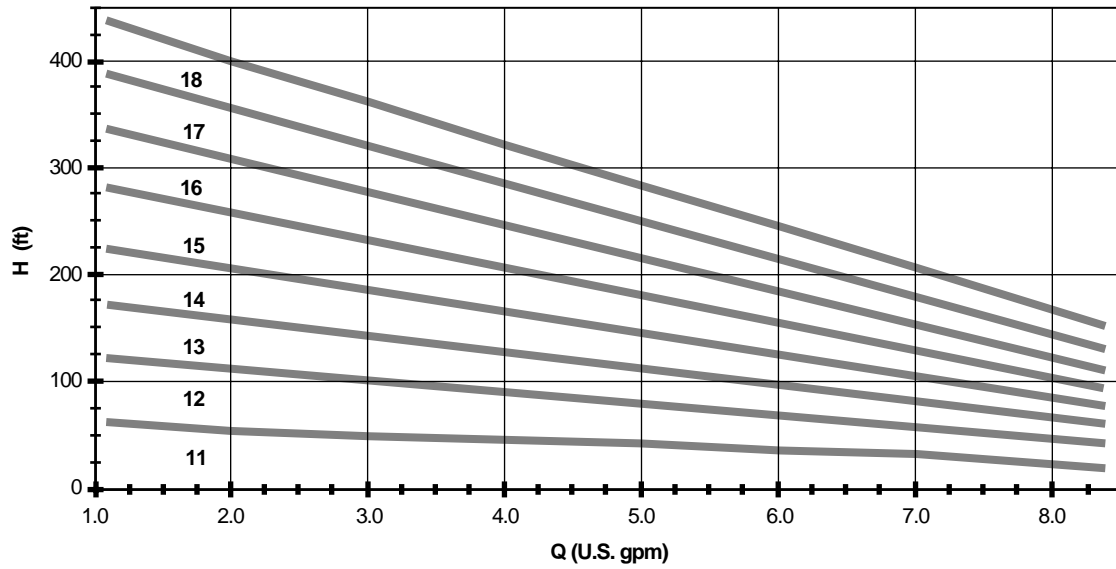

Note: Consult factory for viscosities above 30 SSU

Performance Curves

**SC10 SERIES
1750 RPM**

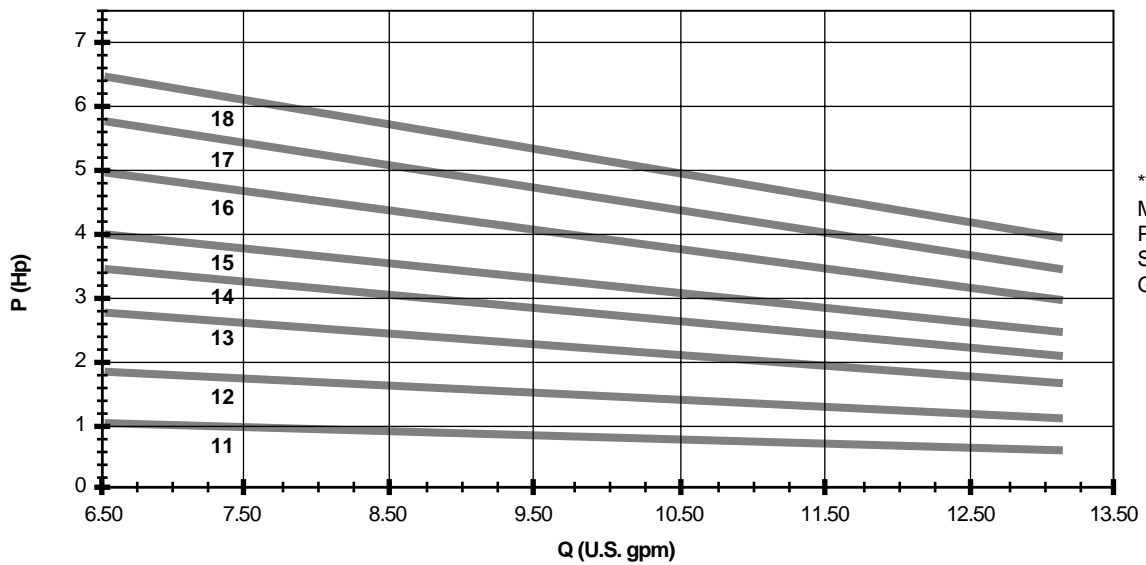
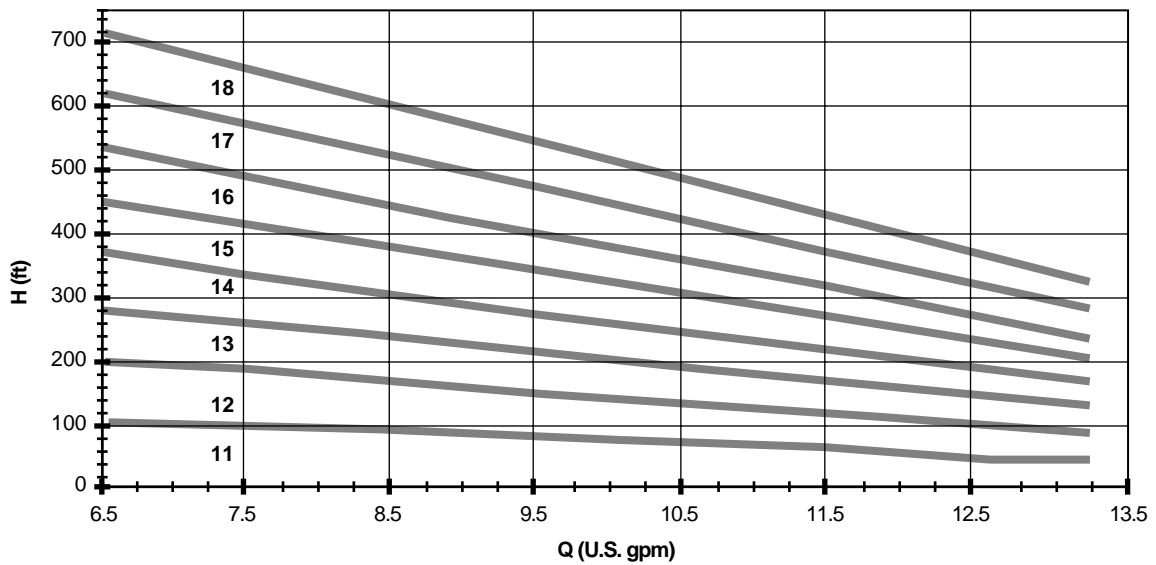

**Note:
Multiply
Power by
Specific
Gravity

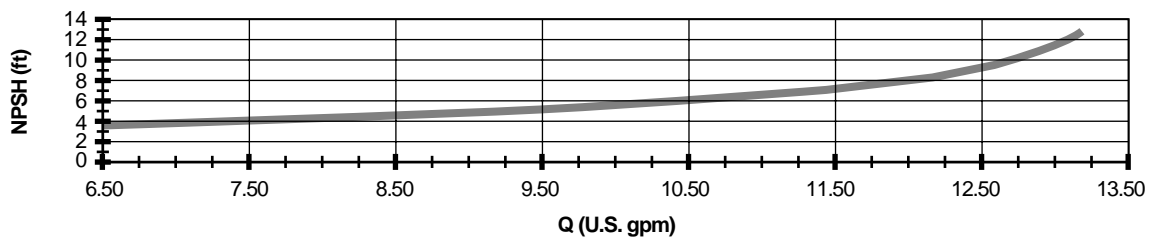

Note: Consult factory for viscosities above 30 SSU

Performance Curves

SC20 SERIES 1150 RPM

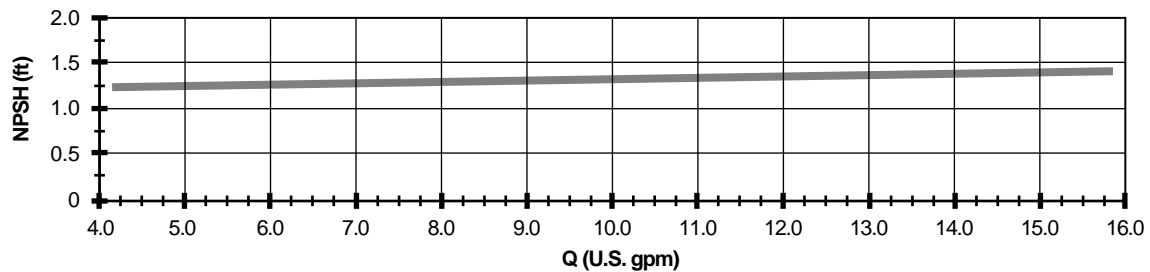
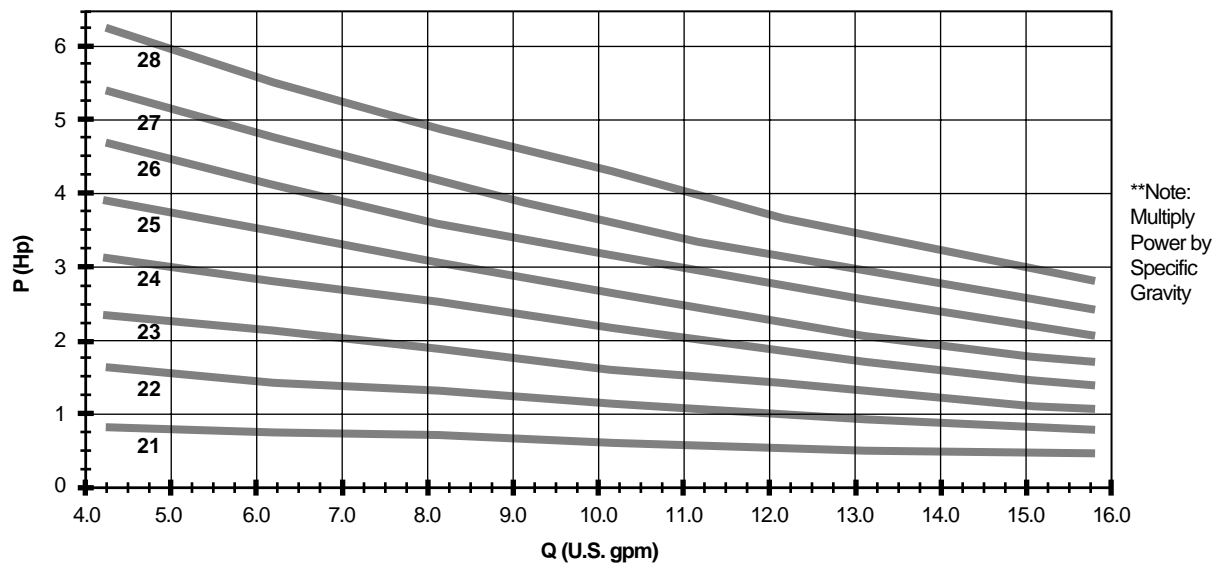
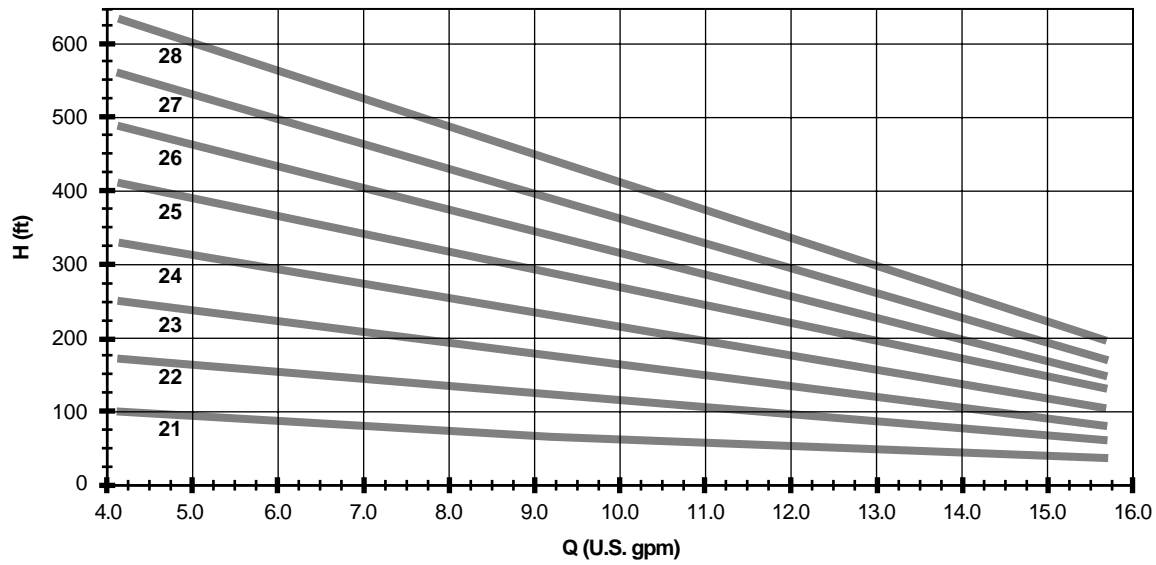

Note: Consult factory for viscosities above 30 SSU

Performance Curves

**SC20 SERIES
1750 RPM**

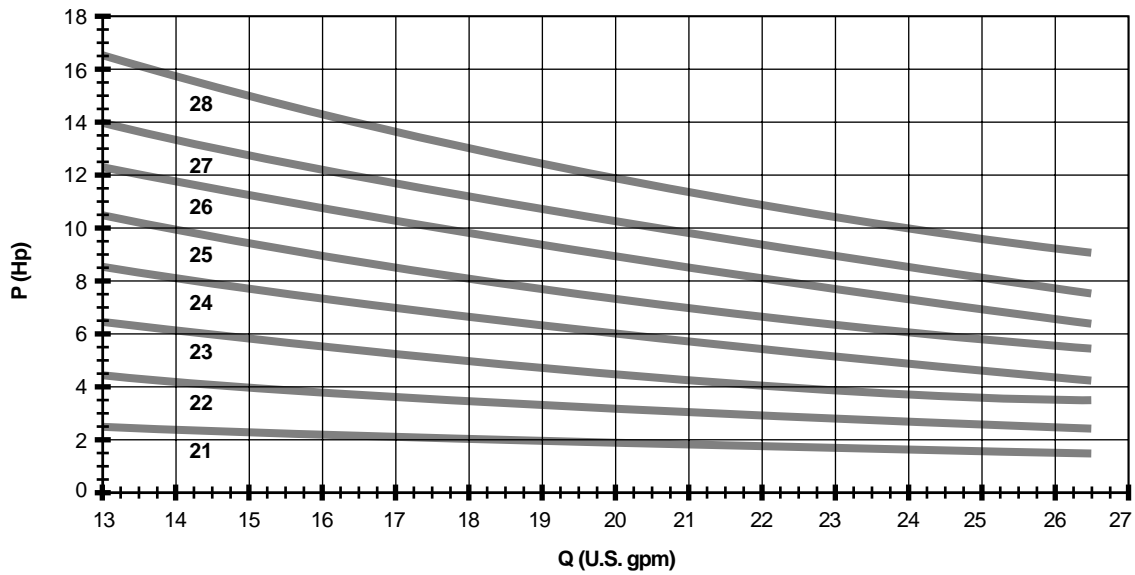
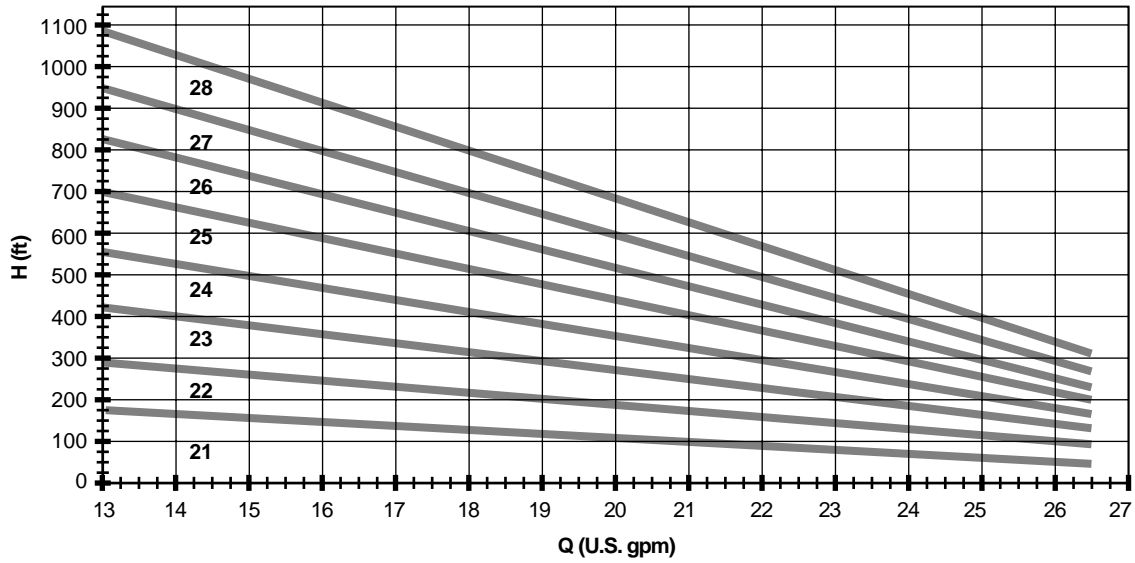

**Note:
Multiply
Power by
Specific
Gravity

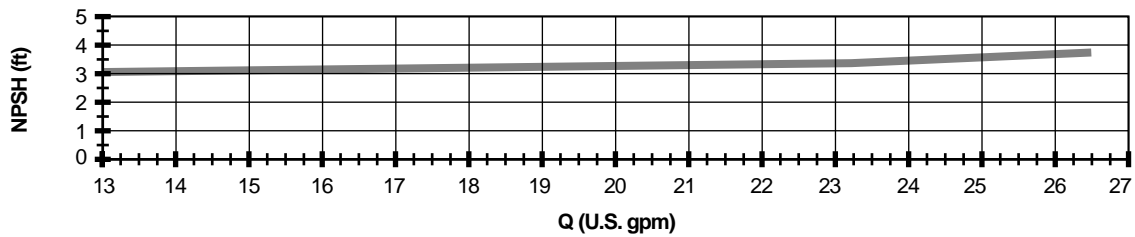

Note: Consult factory for viscosities above 30 SSU

Performance Curves

SC30 SERIES 1150 RPM

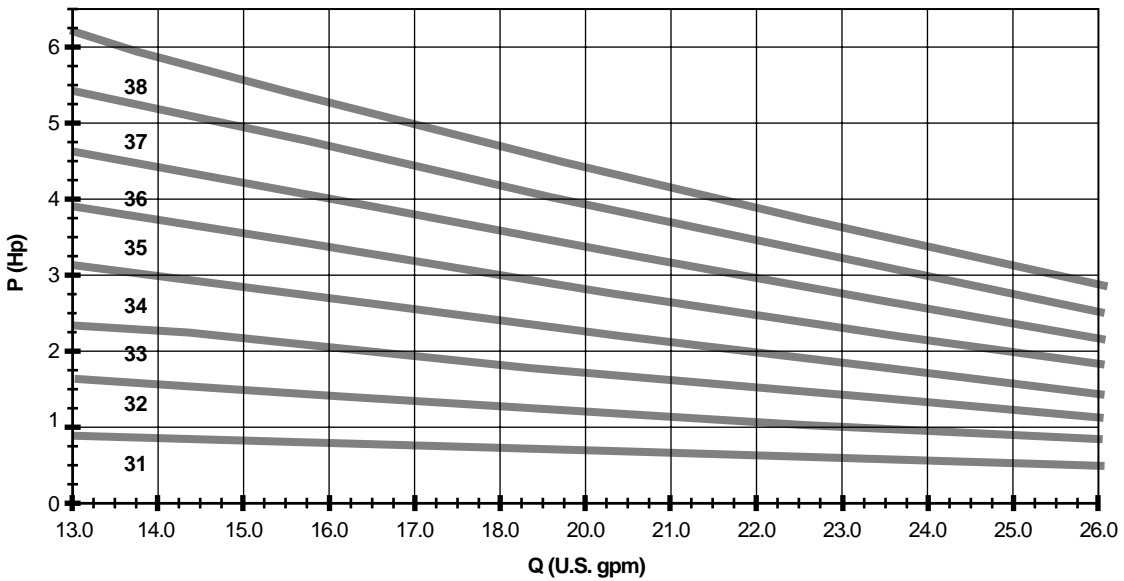
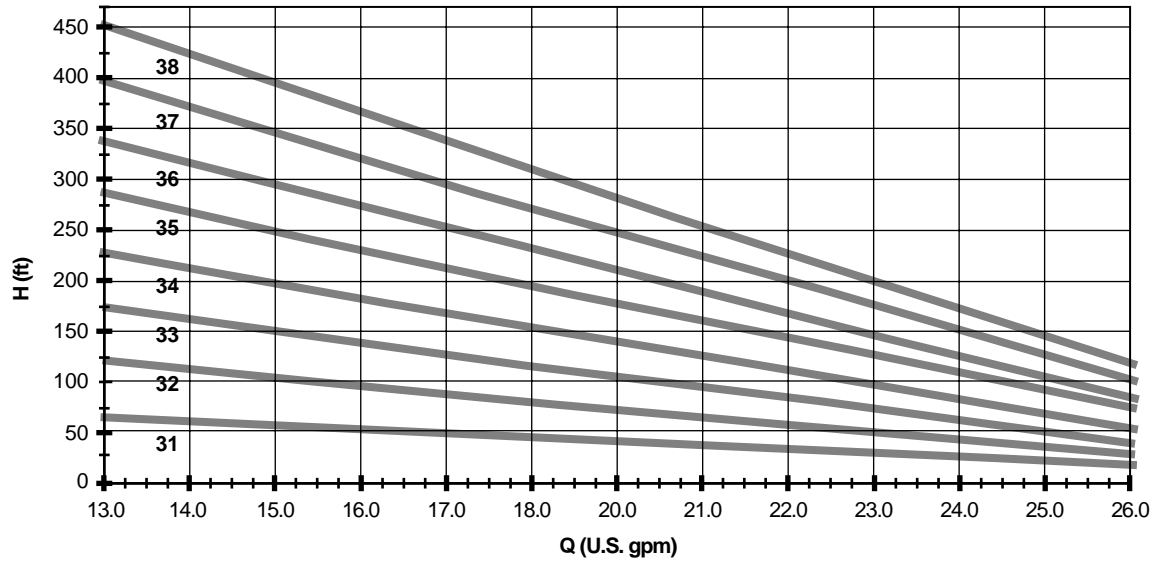

**Note:
Multiply
Power by
Specific
Gravity

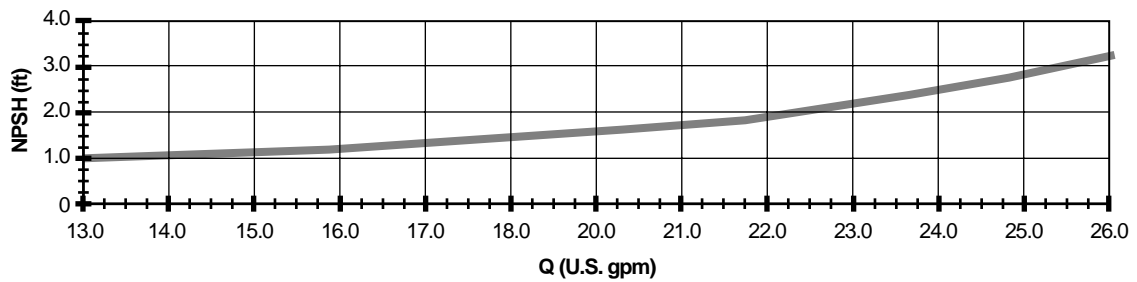

Note: Consult factory for viscosities above 30 SSU

Performance Curves

**SC30 SERIES
1750 RPM**

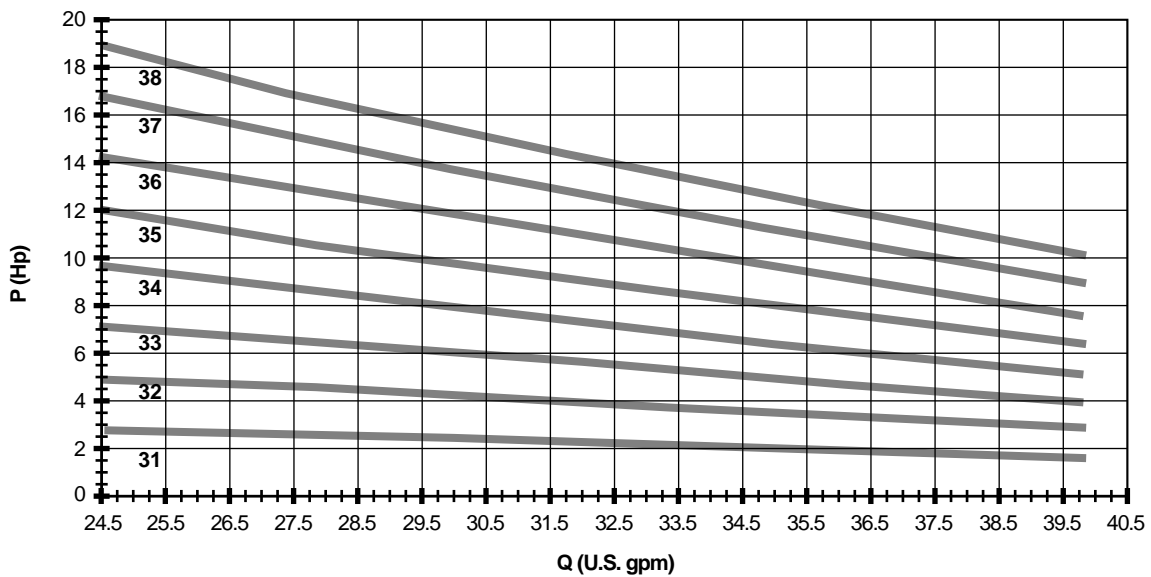
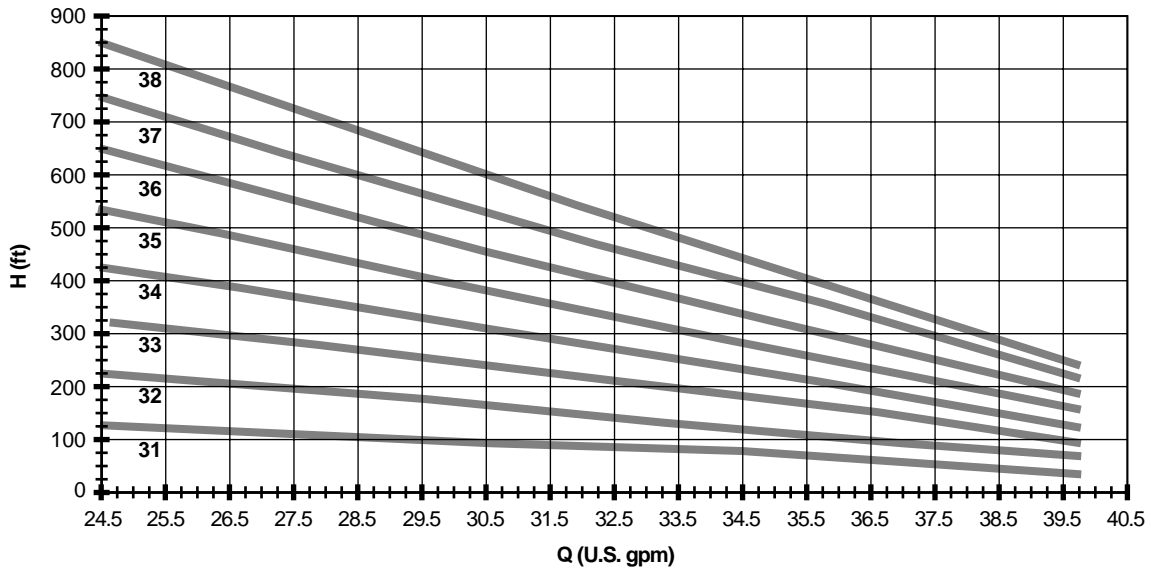

**Note:
Multiply
Power by
Specific
Gravity

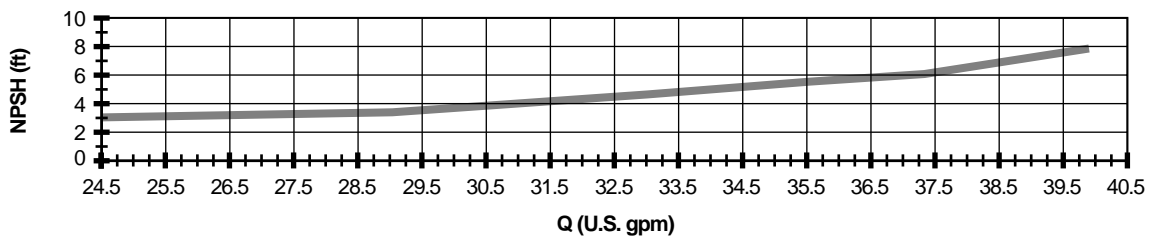

Note: Consult factory for viscosities above 30 SSU

Performance Curves

SC40 SERIES 1150 RPM

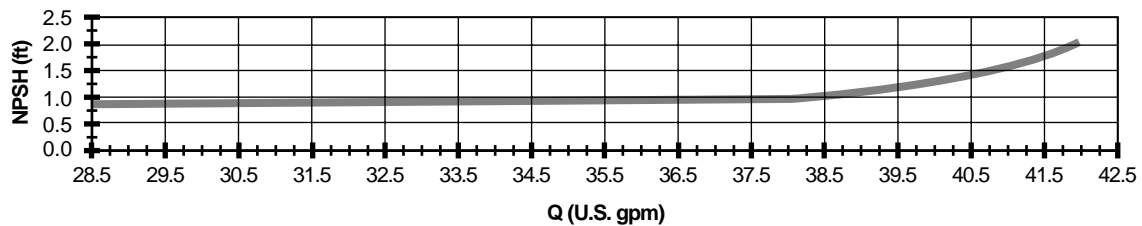
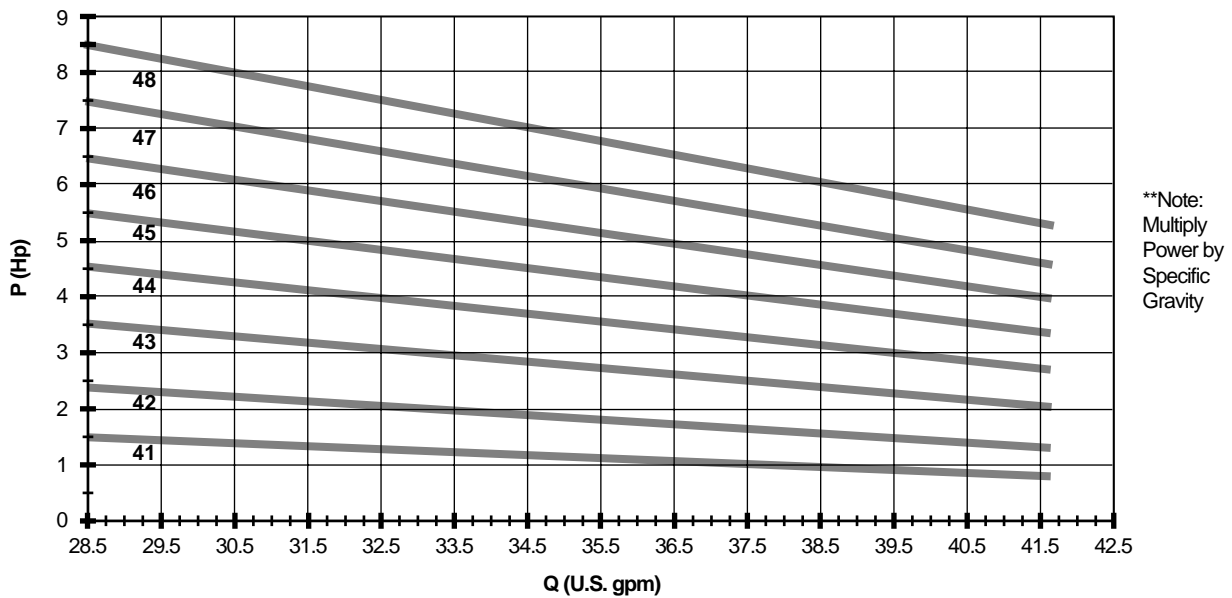
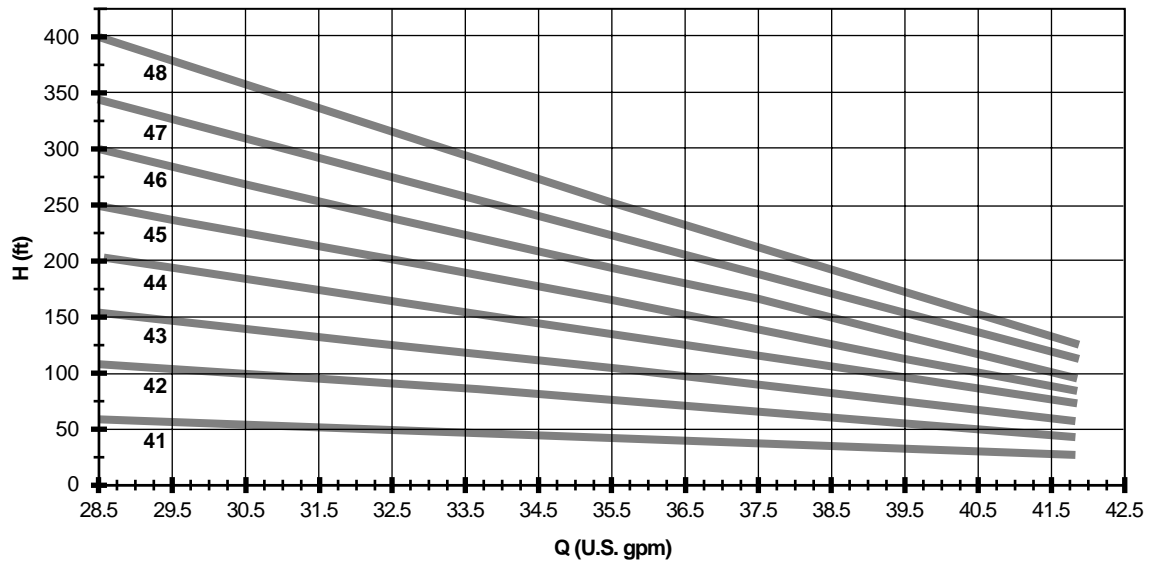

Note: Consult factory for viscosities above 30 SSU

Performance Curves

SC40 SERIES
1750 RPM

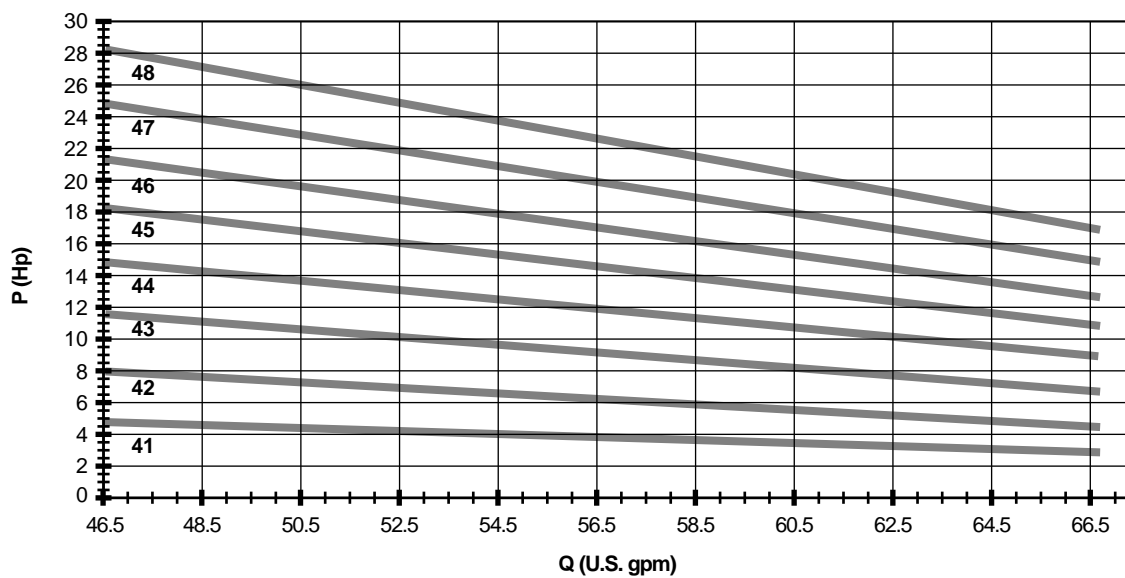
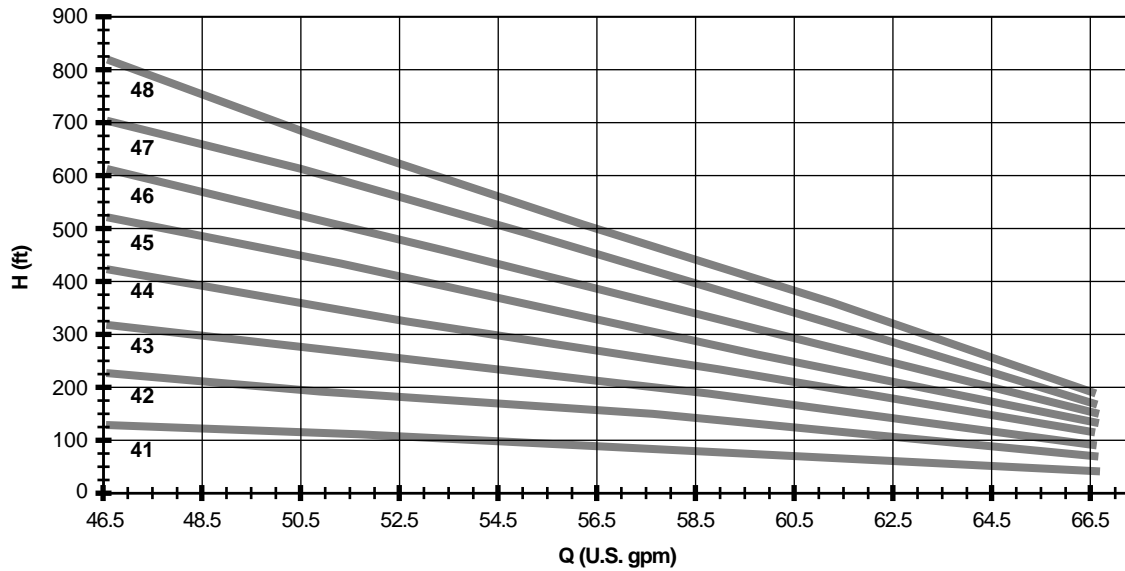

**Note:
Multiply
Power by
Specific
Gravity

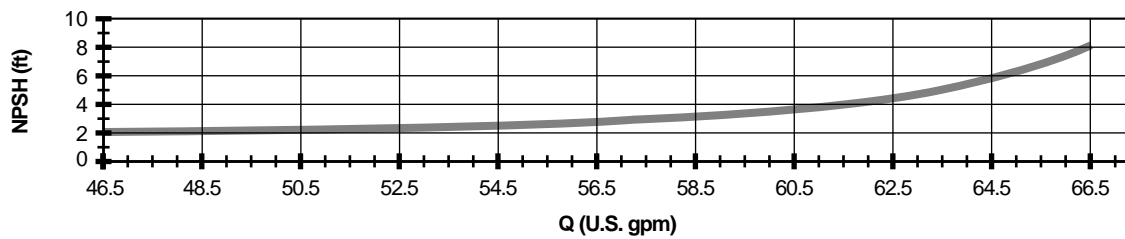

Note: Consult factory for viscosities above 30 SSU

Material Specifications

PART DESCRIPTION	STANDARD MATERIAL	OPTIONAL MATERIAL
Suction Casing Discharge Casing Suction Impeller Casing Suction Stage Casing Discharge Stage Casing	Cast Iron ASTM A48	Ductile Iron ASTM A536 Stainless Steel ASTM A351
Foot	Cast Iron	
Shaft	Stainless Steel ASTM A276	316 Stainless Steel
Impeller Suction Impeller	Bronze	Steel ASTM A743 Stainless Steel ASTM A351
Bearing Bracket	Cast Iron	
Seal Casing	Stainless Steel	
Stage Casing Gasket	Teflon	
Bushing (Stage Casing)	Carbon Graphite	Bronze
Bushing (Stage Casing - K style)	Carbon Graphite Press Fitted into a steel Ring	
Bushing (Suction Impeller Casing)	Carbon Graphite Press Fitted into a Steel Ring with Shaft Sleeve	
Bearing	Deep Groove Ball Bearings	

Dimensional Drawings / Weights

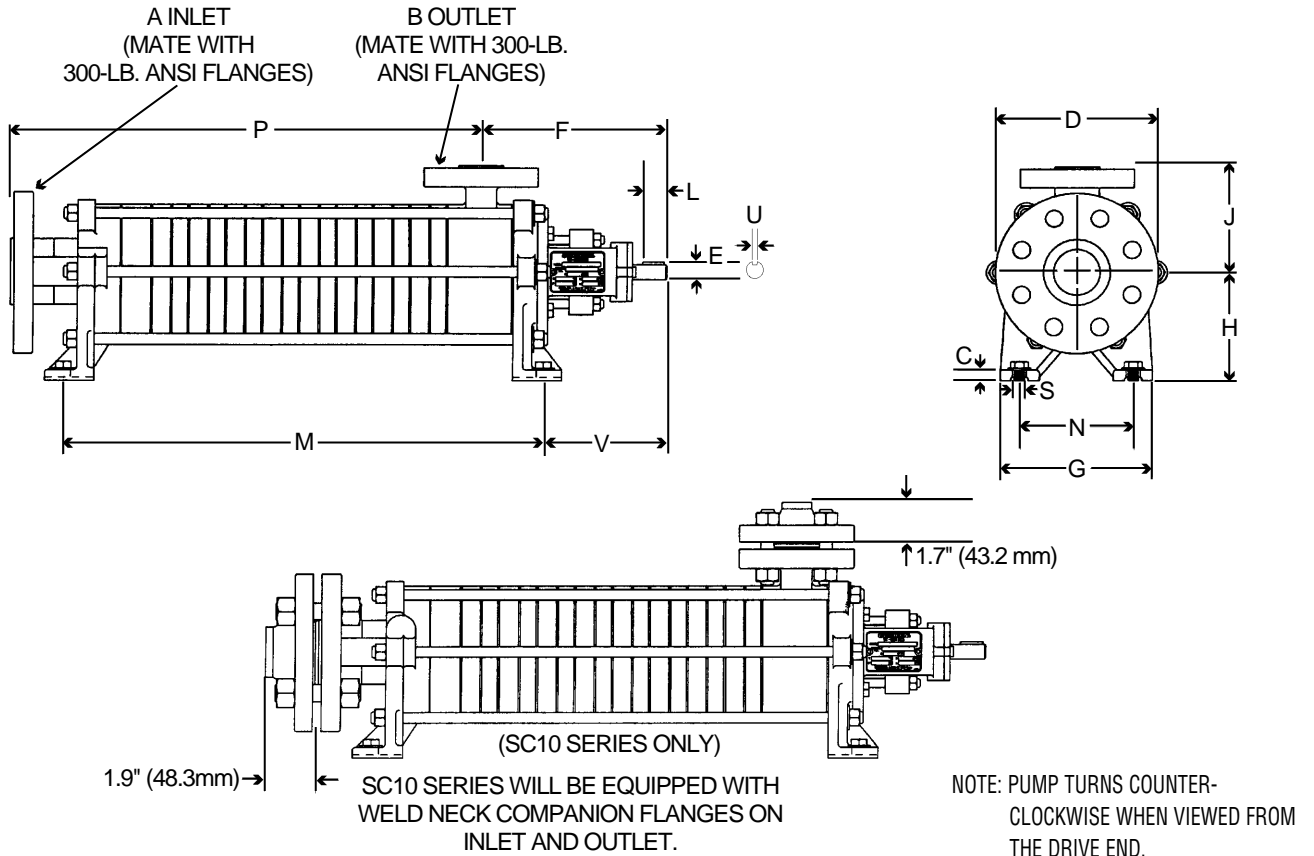

SERIES	A* INLET	B* OUTLET	C	F	H	J	G	N	V	E	L	D	S	U
SC10	1-1/2	3/4	0.39	6.73	3.94	3.94	5.51	4.13	4.45	0.55	0.55	5.91	.51	.20
	40	20	10	171	100	100	140	105	113	14	25	150	13	5
SC20/SC30	2-1/2	1-1/4	0.51	7.91	4.41	5.20	6.69	5.31	5.28	0.75	1.57	7.28	.55	.24
	65	32	13	210	112	132	170	135	134	19	40	185	14	6
SC40	3	1-1/2	0.59	7.68	5.20	5.51	7.68	6.10	5.59	0.94	1.77	7.87	.59	.31
	80	40	15	195	132	140	195	155	142	24	45	200	15	8
SC50	4	2	0.71	9.33	6.30	6.50	8.46	6.69	6.26	1.10	1.97	9.25	.59	.39
	100	50	18	237	160	165	215	170	159	28	50	235	15	10
SC60	4	2-1/2	0.79	10.31	7.09	7.09	9.65	7.68	6.77	1.26	2.56	9.25	.59	.39
	100	65	20	262	180	180	245	195	172	32	65	235	15	10

SERIES	1 STAGE		2 STAGES		3 STAGES		4 STAGES		5 STAGES		6 STAGES		7 STAGES		8 STAGES	
	P	M	P	M	P	M	P	M	P	M	P	M	P	M	P	M
SC10	7.68	8.03	9.02	9.37	10.35	14.65	11.69	12.05	13.03	13.39	14.37	14.72	15.71	16.06	17.05	17.40
	195	204	229	238	263	372	297	306	331	340	365	374	399	408	433	442
SC20/SC30	8.39	8.94	9.96	10.51	11.54	12.09	13.11	13.66	14.69	15.24	16.26	16.81	17.83	18.39	19.41	19.96
	213	227	253	267	293	307	333	347	373	387	413	427	453	467	493	507
SC40	10.55	10.20	12.72	12.36	14.88	14.53	17.05	16.69	19.21	18.86	21.38	21.02	23.54	23.19	26.89	25.35
	268	259	323	314	378	369	433	424	488	479	543	534	598	589	653	644
SC50	12.01	12.32	14.96	15.28	17.91	18.23	20.87	21.18	23.82	24.13	26.77	27.09	29.72	30.04	32.68	32.99
	305	313	380	388	455	463	530	538	605	613	680	688	755	763	830	838
SC60	13.31	13.90	16.85	17.44	20.39	20.98	23.94	24.53	27.48	28.07	31.02	31.61	34.57	35.16	38.11	38.70
	338	353	428	443	518	533	608	623	698	713	788	803	878	893	968	983

* INLET AND OUTLET FLANGES ARE PER DIN SPEC (PN40 DIN 2501).
FLANGES CAN BE DRILLED PER ANSI FOR 300-LB. FLANGES, EXCEPT FOR SC10 SERIES.

DIMENSIONS SHOWN IN GREY AREA ARE MILLIMETERS; OTHERS ARE INCHES.

Spare Parts with Exploded View

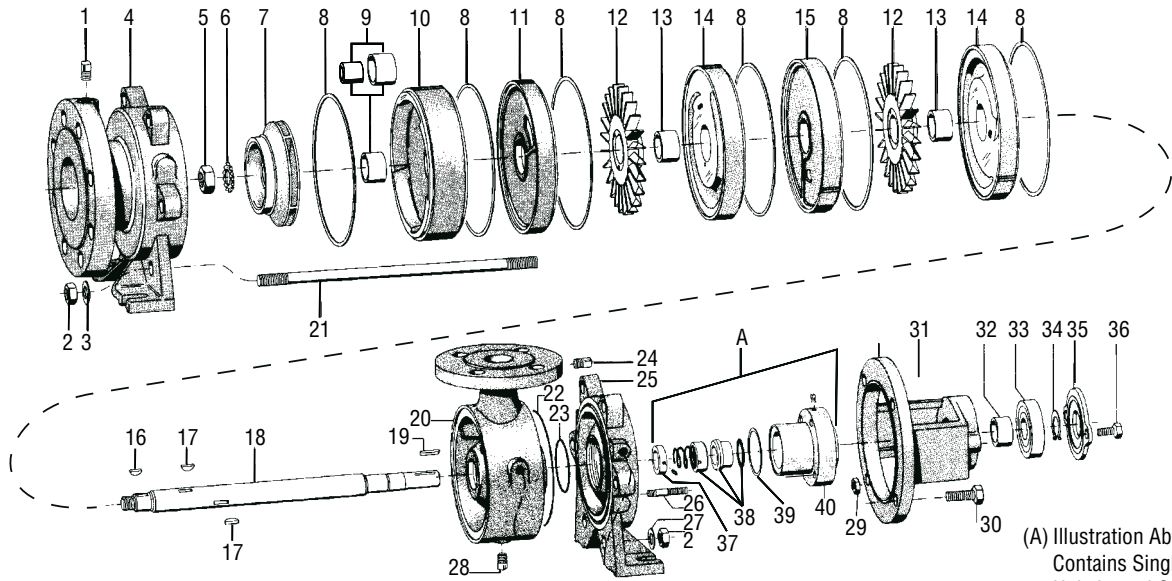

(A) Illustration Above Contains Single Unbalanced Seal. Optional Seals are Displayed Below.

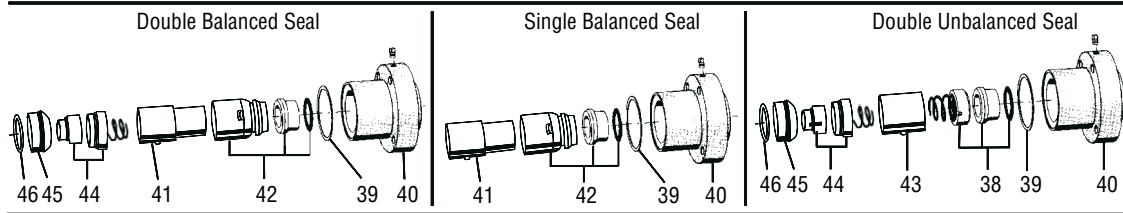

ITEM	DESCRIPTION
1	SUCTION CASING PLUG (SC10 - 1/8"; SC60 - 3/8"; SC20-SC50 - 1/4")
2	TIE BOLT HEX NUT
3	TIE BOLT WASHER
4	SUCTION CASING
5	SUCTION IMPELLER HEX NUT
6	SUCTION IMPELLER LOCK WASHER
7	SUCTION IMPELLER
8	CASING GASKET
9	SUCTION IMPELLER CASING BUSHING AND SLEEVE
10	SUCTION IMPELLER CASING
11	FIRST SUCTION STAGE CASING
12	IMPELLER
13	STAGE CASING BUSHING
14	DISCHARGE STAGE CASING
15	SUCTION STAGE CASING
16	SUCTION IMPELLER WOODRUFF KEY
17	STAGE IMPELLER WOODRUFF KEY
18	SHAFT
19	SHAFT DRIVE KEY
20	DISCHARGE CASING
21	TIE BOLT
22	DISCHARGE CASING O-RING (USED WITH COOLING OPTION)
23	FOOT O-RING (USED WITH COOLING OPTION)
24	DISCHARGE CASING PLUG (NOT AVAILABLE ON SC60) (1/4" STRAIGHT CONNECTION)

ITEM	DESCRIPTION
25	FOOT
26	STUD BOLT
27	TIE BOLT WASHER (OPTIONAL ON SOME UNITS)
28	DISCHARGE CASING DRAIN PLUG
29	SEAL HOUSING HEX NUT
30	BEARING BRACKET SCREW
31	BEARING BRACKET
32	BEARING SPACER SLEEVE WITH THROWER O-RING
33	ROLLER BALL BEARING
34	BEARING RETAINER RING
35	BEARING COVER PLATE
36	SCREW
37	SEAL LOCATOR RING
38	UNBALANCED MECHANICAL SEAL WITH SEAT O-RING
39	SEAL HOUSING GASKET
40	SEAL HOUSING
41	SEAL LOCATOR AND SLEEVE WITH SLEEVE O-RING
42	BALANCED MECHANICAL SEAL WITH SEAT O-RING
43	SEAL LOCATOR RING (DOUBLE UNBALANCED SEAL)
44	INNER UNBALANCED MECHANICAL SEAL WITH SEAT O-RING (DOUBLE SEALS ONLY)
45	SEAL COLLAR WITH O-RING (DOUBLE SEALS ONLY)
46	SEAL COLLAR GASKET (DOUBLE SEALS ONLY)

Coro-Flo Turbine Pumps

Corken's Coro-Flo product has a successful history in liquefied gas service. For low capacity, medium head pressure requirements Coro-Flo is the pump of choice. Extremely quiet and free of vibration and pulsation, the Coro-Flo Pump provides extended trouble free service.

Where higher head pressures are required, an economical solution is to incorporate two Coro-Flo pumps in a Duplex series pump set. In this case both pumps may operate in winter months when higher differential pressures are required and only one pump is used under normal operating conditions.

The Coro-Flo pump has been designed for simplicity and service. The cover can be removed and the impeller and seal serviced without disturbing the piping. The balanced mechanical seal is furnished with its own sleeve, providing extremely reliable service. The newly offered DS/DL model seen below is designed to accept standard NEMA C flanged motors assuring proper alignment to further simplify installation and extend seal and bearing life.



F Model

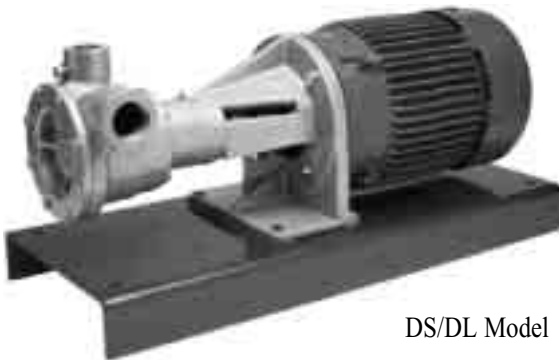

DS/DL Model

SPECIFICATIONS	MODEL				
	9	10	12	13	14
Inlet	1-1/4" NPT	1-1/4" NPT	1-1/2" NPT	1-1/2" NPT	1-1/2" NPT
Outlet	1" NPT	1" NPT	1" NPT	1" NPT	1" NPT
RPM-50 Hz	2880	2880	2880	2880	2880
RPM-60 Hz	3450	3450	3450	3450	3450
Max. Differential Press.					
50 Hz PSI (Bar)	135 (9.3)	135 (9.3)	150 (10.3)	150 (10.3)	150 (10.3)
60 Hz PSI (Bar)	150 (10.3)	150 (10.3)	150 (10.3)	150 (10.3)	150 (10.3)
Mounting Options					
Direct Driven (101)	Yes	Yes	Yes	Yes	Yes
Direct Mounted Frame (DS/DL)	Yes	Yes	Yes	Yes	Yes
Double Seal Option	Yes	Yes	Yes	Yes	Yes
Flange Option 1-1/2" x 1" - 300#	Yes	Yes	Yes	Yes	Yes
Impeller Material Opt.	Bronze (standard), Ductile Iron, Stainless Steel				
O-ring Material Opt.:	Buna N (standard), Neoprene®, Teflon®, Viton®, Ethylene-Propylene				
Seal Seat Material	Cast Iron (standard), Ni-Resist, Stainless Steel, Tungsten Carbide, Ceramic				
Temperature (min/max)	-25/225 °F -32/107 °C	-25/225 °F -32/107 °C	-25/225 °F -32/107 °C	-25/225 °F -32/107 °C	-25/225 °F -32/107 °C

Above differential pressures are based on a 1.2 specific gravity.

Performance Curves

CHARACTERISTIC CURVES FOR MODELS 10, 12, 14 3450 RPM

CAPACITY

Determine the specific gravity and the total head in feet required for the fluid being handled. The head in feet can be calculated from the following formula by knowing the differential pressure in PSI:

$$\text{Head In Feet} = \frac{(2.31) \times (\text{PSI})}{(\text{Specific Gravity})}$$

Enter the curves at the appropriate Head, read horizontally to intersect the proper Capacity line and vertically down to find the Capacity in GPM.

HORSEPOWER

Enter the curves at the appropriate Head, read horizontally to the heavy Capacity line, vertically down to the corresponding Horsepower line and horizontally to read Horsepower. Multiply the Horsepower reading by the specific gravity to calculate the Horsepower required for the application. These curves are based on a minimum static head of 4 feet and properly designed inlet piping.

Note: Differential pressure must not exceed 150 psi for the Coro Flo model pumps.

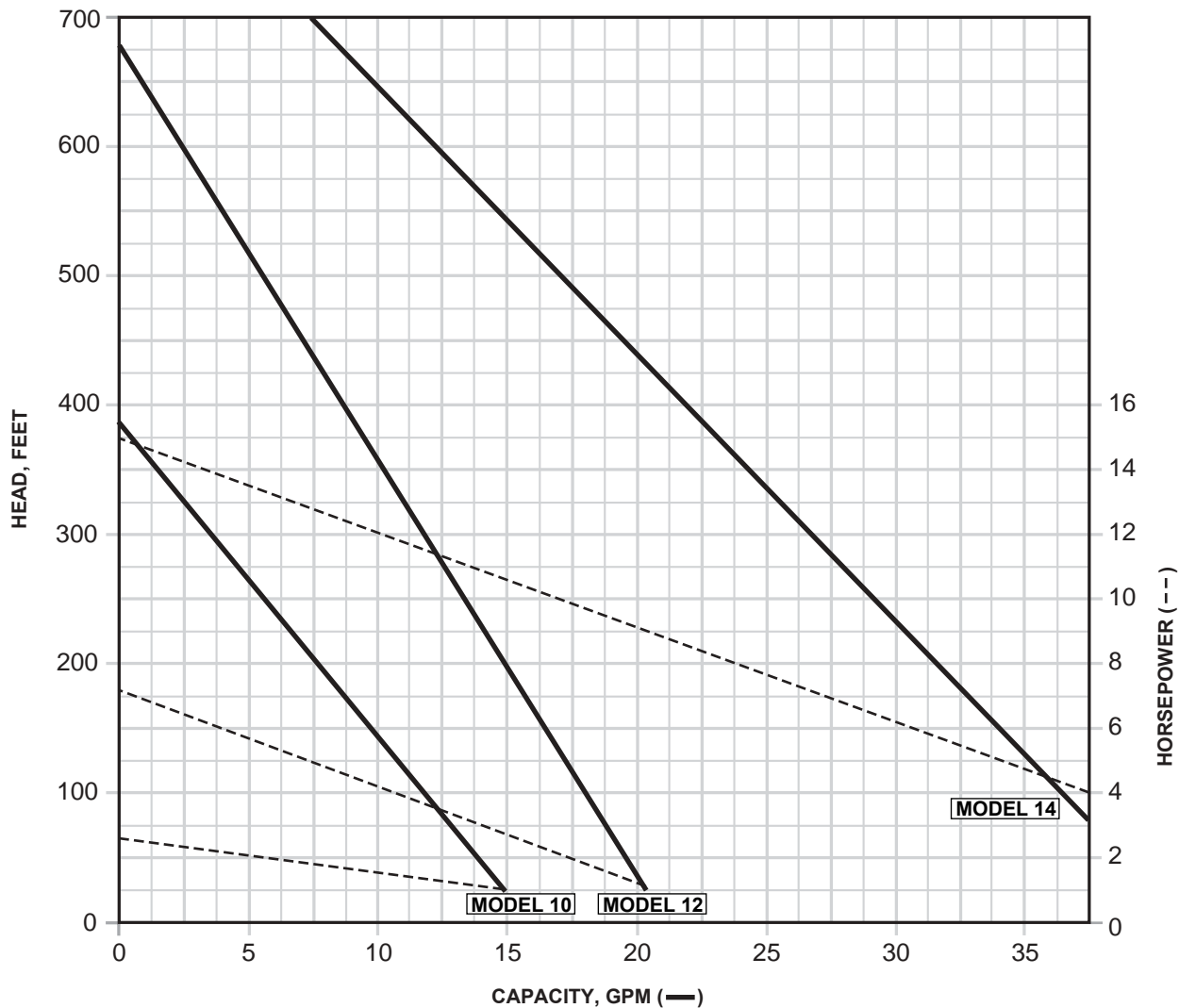

CHARACTERISTIC CURVES FOR MODELS 9, 13, 15 3450 RPM

CAPACITY

Determine the specific gravity and the total head in feet required for the fluid being handled. The head in feet can be calculated from the following formula by knowing the differential pressure in PSI:

$$\text{Head In Feet} = \frac{(2.31) \times (\text{PSI})}{(\text{Specific Gravity})}$$

Enter the curves at the appropriate Head, read horizontally to intersect the proper Capacity line and vertically down to find the Capacity in GPM.

HORSEPOWER

Enter the curves at the appropriate Head, read horizontally to the Capacity line, vertically down to the Horsepower line and horizontally to read Horsepower. Multiply the Horsepower reading by the specific gravity to calculate the Horsepower required for the application. These curves are based on a minimum static head of 4 feet and properly designed inlet piping.

Note: Differential pressure must not exceed 150 psi for the Coro Flo model pumps.

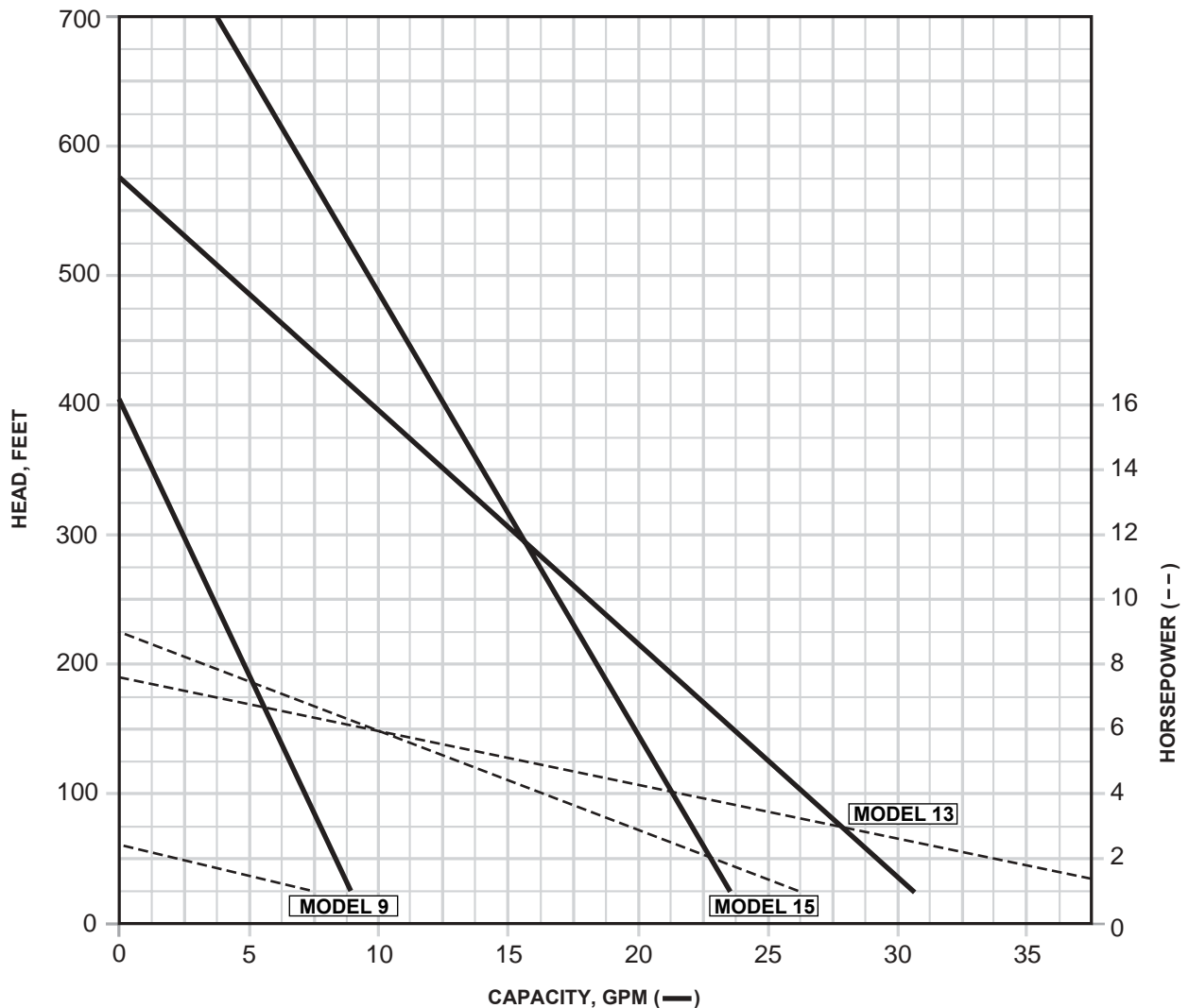

Performance Curves

MATERIAL SPECIFICATIONS

F-MODEL

PART	STANDARD		OPTIONAL	
	SIZE	MATERIAL	SIZE	MATERIAL
CASE, COVER	ALL	DUCTILE IRON ASTM A536		NONE
IMPELLER	ALL	BRONZE	ALL	DUCTILE IRON 416 STAINLESS STEEL
IMPELLER KEY	ALL	STEEL	ALL	STAINLESS STEEL
SEAL SEAT	ALL	CAST IRON	ALL	304 STAINLESS STEEL NI-RESIST CAST IRON CERAMIC TUNGSTEN CARBIDE
SEAL ROTOR	ALL	CARBON		NONE
SEAL METAL PARTS	ALL	STEEL		NONE
SEAL SLEEVE	ALL	ALUMINUM	ALL	416 STAINLESS STEEL
SEAL FOLLOWER	ALL	ALUMINUM	ALL	416 STAINLESS STEEL
SEAL HOUSING	ALL	STEEL, CADMIUM PLATED	ALL	416 STAINLESS STEEL
SHAFT	F-MODELS	"STRESS PROOF" STEEL	F-MODELS	416 STAINLESS STEEL
FRAME	F-MODELS	GRAY IRON ASTM A48, CLASS 30		NONE
BEARING CAP	F-MODELS	ALUMINUM		NONE
O-RINGS	ALL	BUNA-N	ALL	PTFE, VITON*, NEOPRENE*, ETHYLENE-PROPYLENE
RETAINER RINGS	F-MODELS	STEEL		NONE
BEARINGS	ALL	BALL		NONE

*Viton and Neoprene are registered trademarks of Dupont

DS/DL MODEL

PART	STANDARD		OPTIONAL	
	SIZE	MATERIAL	SIZE	MATERIAL
CASE, COVER	ALL	DUCTILE IRON ASTM A536		NONE
IMPELLER	ALL	BRONZE	ALL	DUCTILE IRON 416 STAINLESS STEEL
IMPELLER KEY	ALL	STEEL	ALL	STAINLESS STEEL
SEAL SEAT	ALL	CAST IRON	ALL	304 STAINLESS STEEL NI-RESIST CAST IRON CERAMIC TUNGSTEN CARBIDE
SEAL ROTOR	ALL	CARBON		NONE
SEAL METAL PARTS	ALL	STEEL		NONE
SEAL SLEEVE	ALL	ALUMINUM	ALL	416 STAINLESS STEEL
SEAL FOLLOWER	ALL	ALUMINUM	ALL	416 STAINLESS STEEL
SEAL HOUSING	ALL	STEEL, CADMIUM PLATED	ALL	416 STAINLESS STEEL
SHAFT	F-MODELS	"STRESS PROOF" STEEL	F-MODELS	416 STAINLESS STEEL
O-RINGS	ALL	BUNA-N	ALL	PTFE, VITON*, NEOPRENE*, ETHYLENE-PROPYLENE
BEARINGS	ALL	BALL		NONE

*Viton and Neoprene are registered trademarks of Dupont

FRAME-MOUNTED OUTLINE DIMENSIONS

F9 - F15

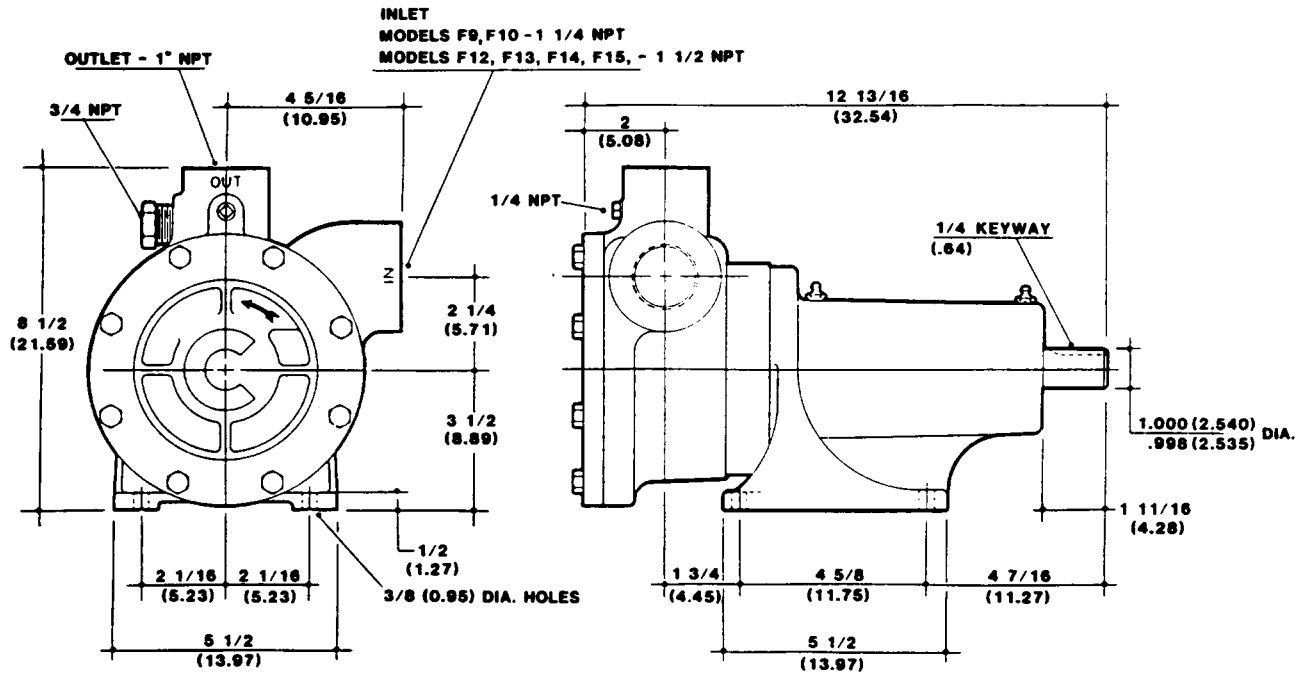

FF9 - FF15

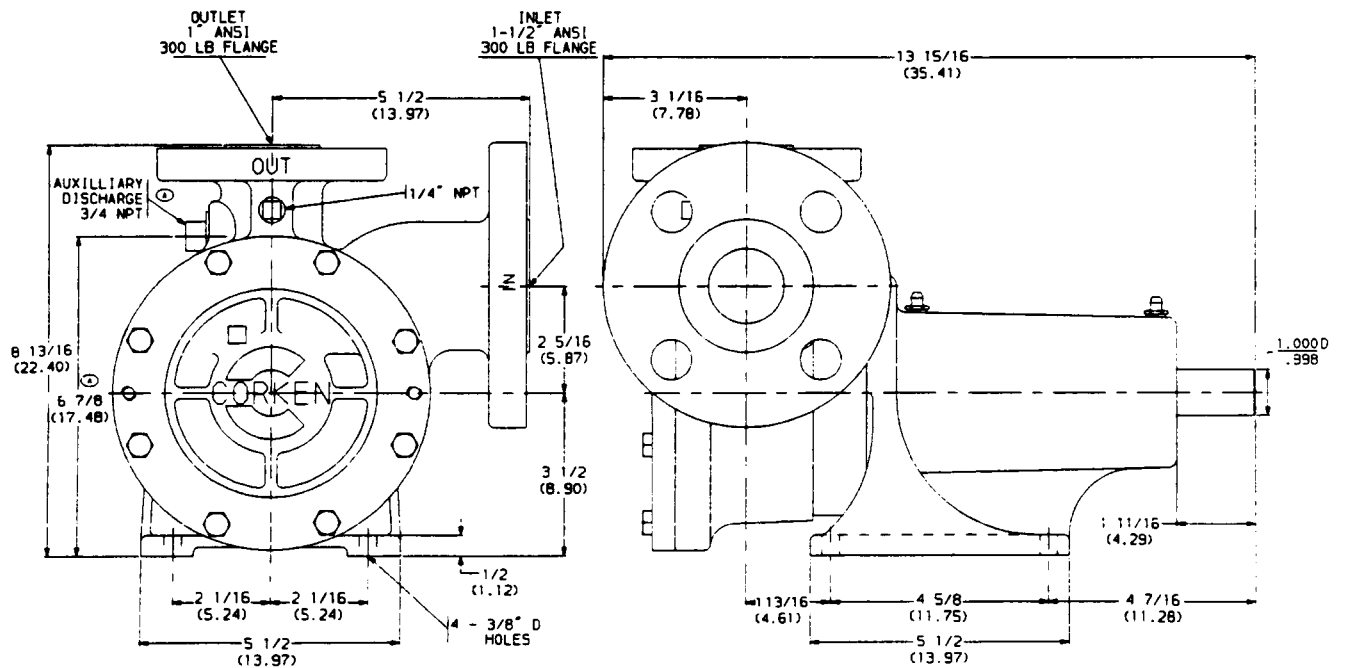

Dimensional Drawings / Weights

DIRECT-MOUNTED OUTLINE DIMENSIONS SMALL MOTOR FRAME 56C-145TC

DS9 - DS15

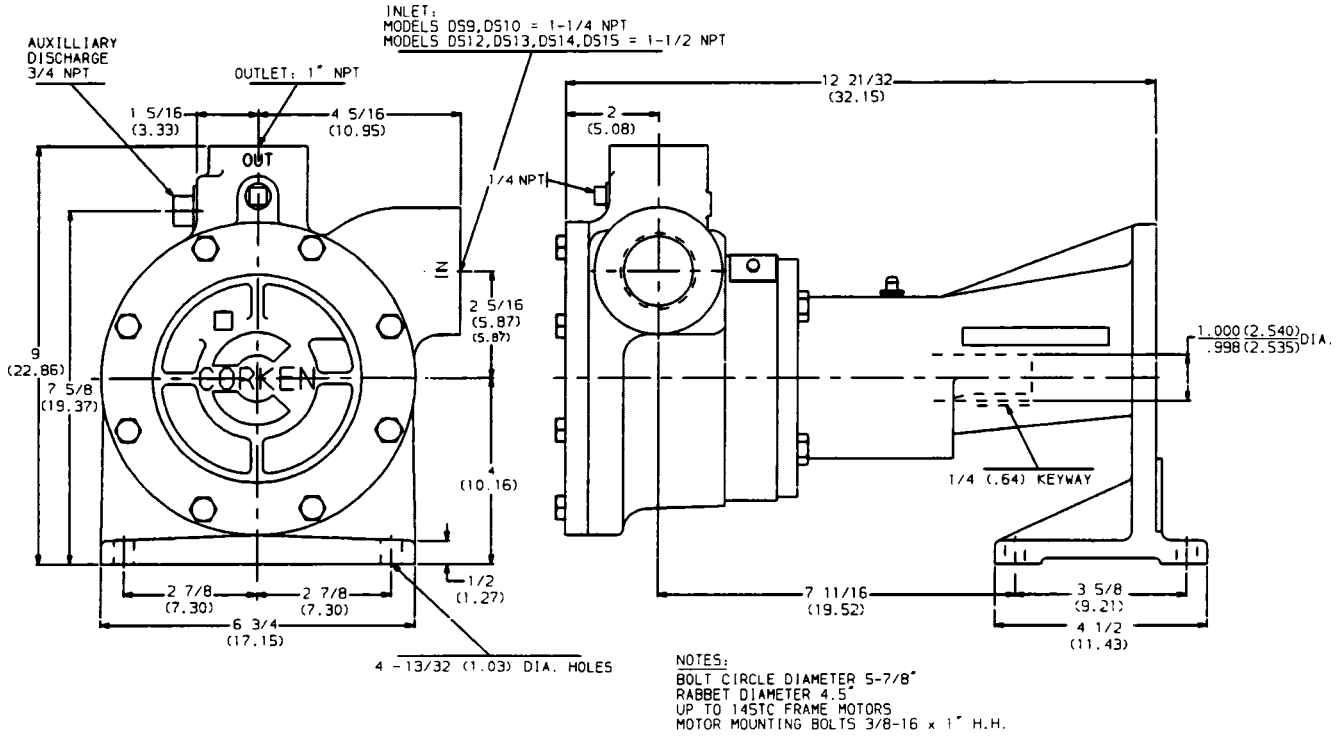

DSF9 - DSF15

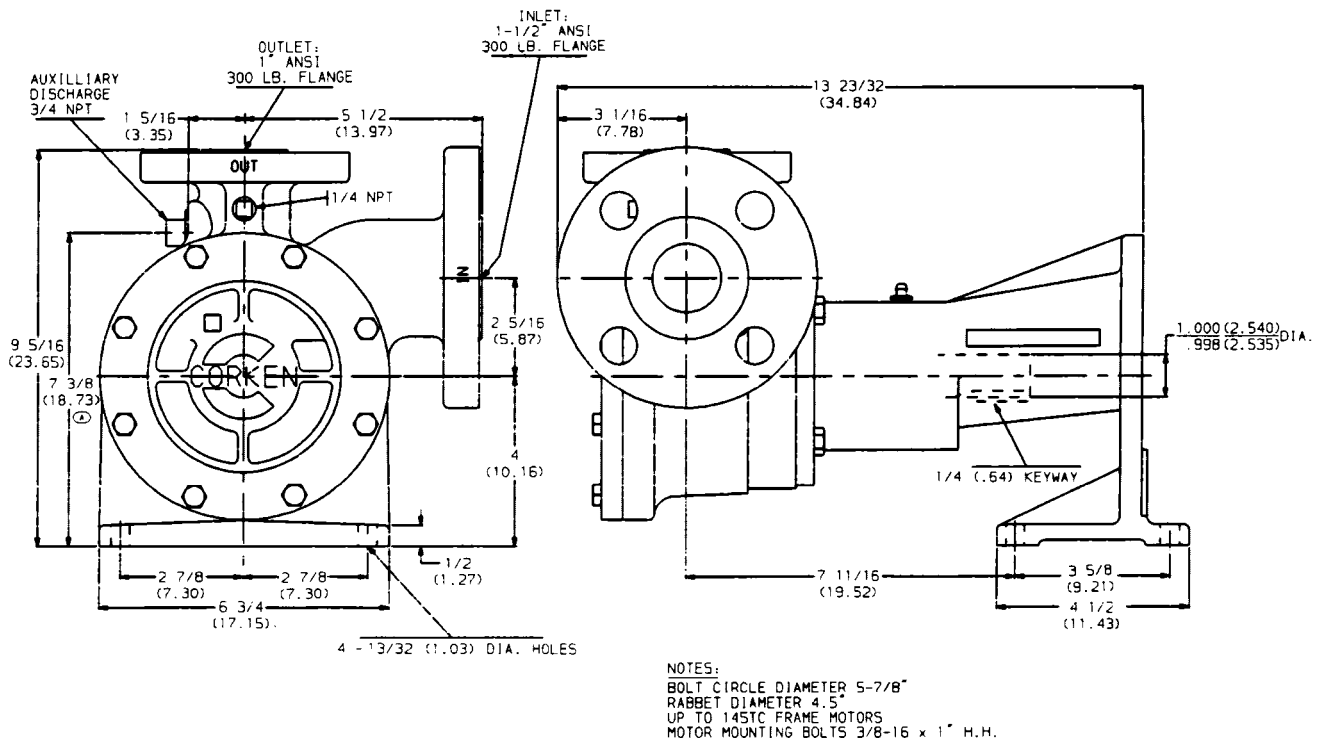

**DIRECT-MOUNTED OUTLINE DIMENSIONS
LARGE MOTOR FRAME 182TC-215TC**

DL9 - DL15

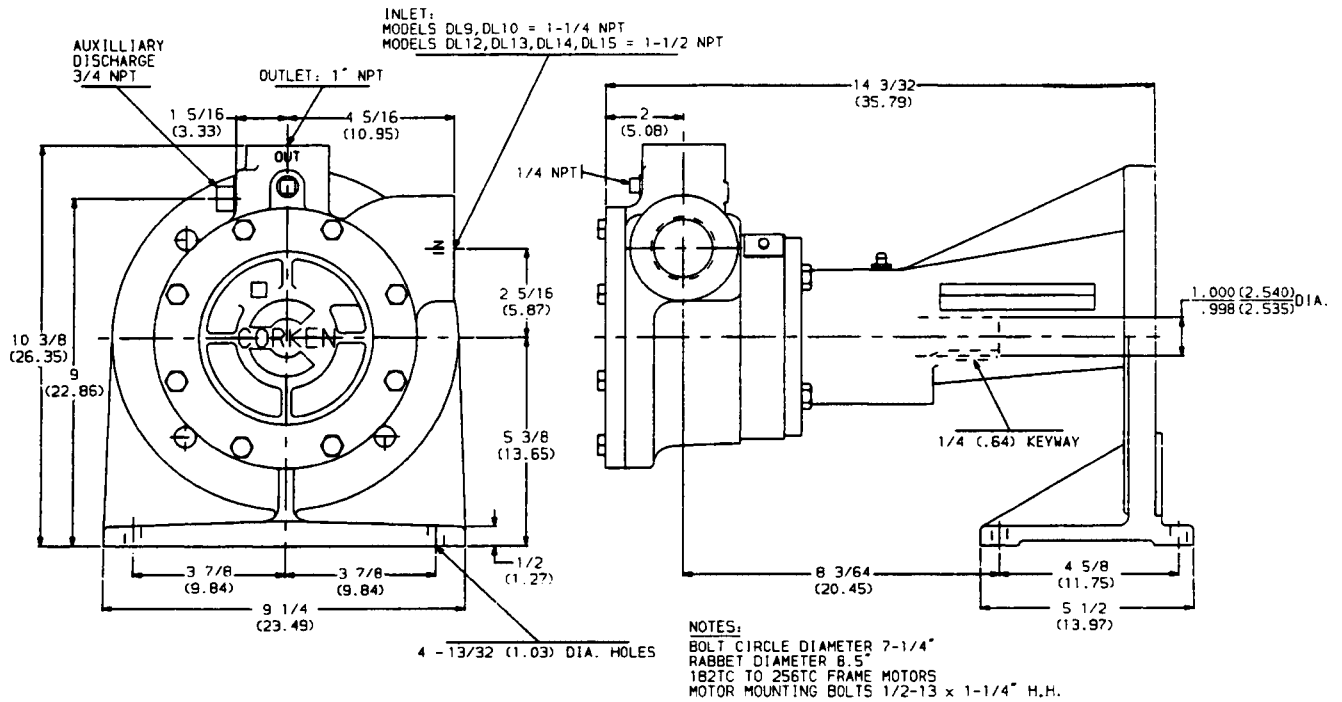

DLF9 - DLF15

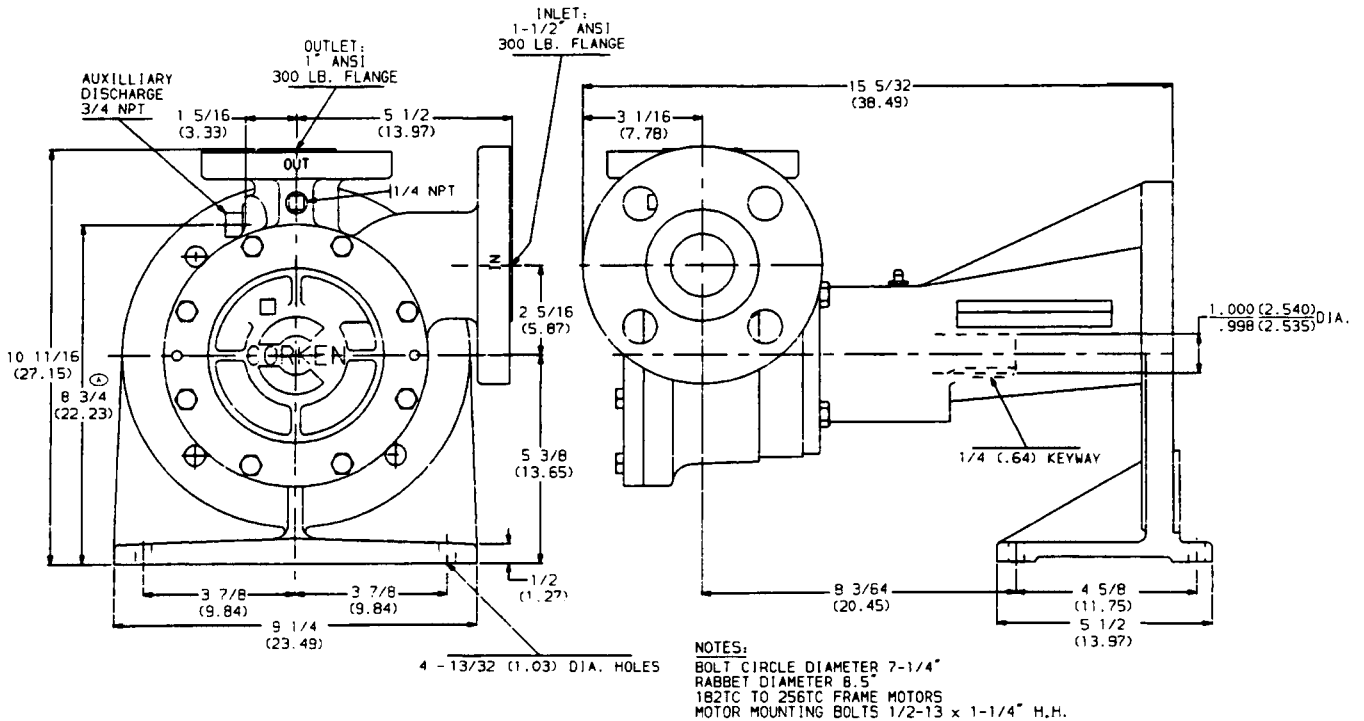

Duplex Unit

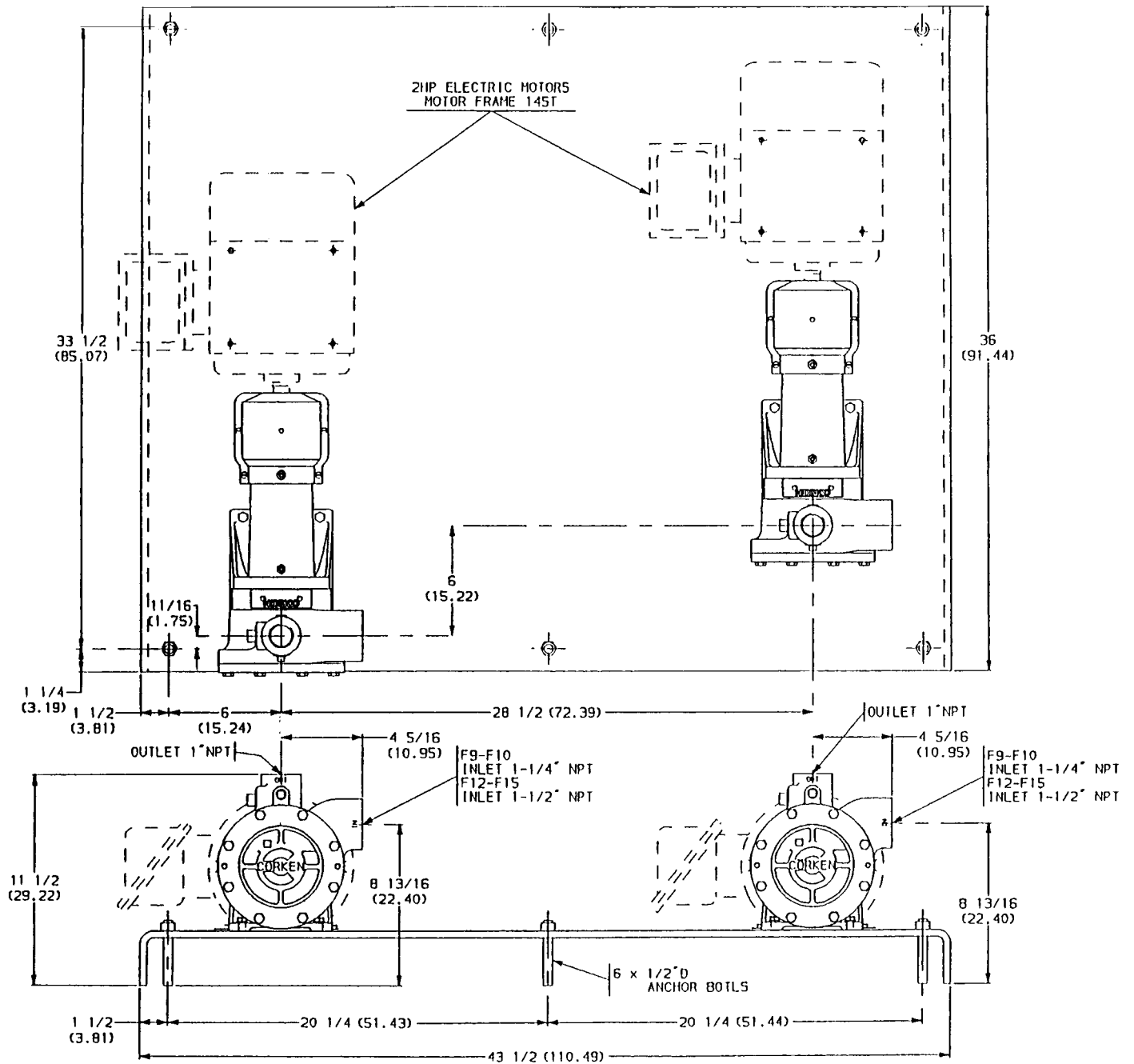

Note: Consult factory for piping and valve recommendations for a duplex setup.

Spare Parts with Exploded View

PARTS DETAILS CORO-FLO PUMPS MODELS F9 TO F15, FF9 TO FF15

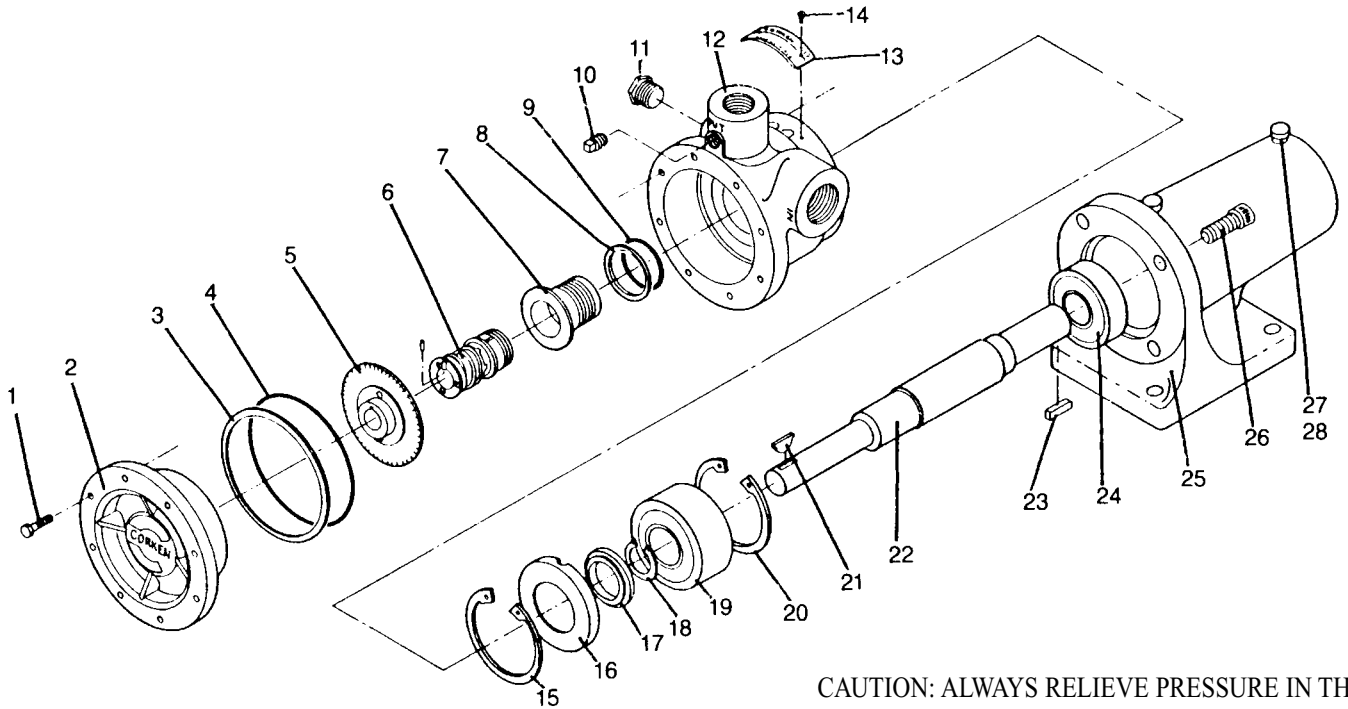

CAUTION: ALWAYS RELIEVE PRESSURE IN THE UNIT BEFORE ATTEMPTING ANY REPAIRS.

REF. NO.	PART NO.	PART NAME	QTY.
1.	7001-031NC100A	HEX HEAD CAP SCREW	8
2.	1001-09	COVER (MODEL 9)	1
	1001-0	COVER (MODEL 10)	1
	1001-2	COVER (MODEL 12)	1
	1001-3	COVER (MODEL 13)	1
	1001-4	COVER (MODEL 14)	1
	1001-5	COVER (MODEL 15)	1
(a) 3.	1014	CASE CLEARANCE SHIM (.002" RED)	As Req.
(a)	1014-1	CASE CLEARANCE SHIM (.003" GREEN)	As Req.
(a) 4.	2-246	O-RING (CASE) (EXCEPT TFE)	1
(a)	2-247E	O-RING (CASE) (TFE)	1
5.	1003-09	IMPELLER BRASS	1
	1003-091	IMPELLER IRON (MODEL 9)	1
	1003-092	IMPELLER STAINLESS STEEL	1
	1003-0	IMPELLER BRASS	1
	1003-01	IMPELLER IRON (MODEL 10)	1
	1003-02	IMPELLER STAINLESS STEEL	1
	1003-2	IMPELLER BRASS	1
	1003-21	IMPELLER IRON (MODEL 12)	1
	1003-22	IMPELLER STAINLESS STEEL	1
	1003-3	IMPELLER BRASS	1
	1003-31	IMPELLER IRON (MODEL 13)	1
	1003-32	IMPELLER STAINLESS STEEL	1
	1003-4	IMPELLER BRASS	1
	1003-41	IMPELLER IRON (MODEL 14)	1
	1003-42	IMPELLER STAINLESS STEEL	1
	1003-5	IMPELLER BRASS	1
	1003-51	IMPELLER IRON (MODEL 15)	1
	1003-52	IMPELLER STAINLESS STEEL	1
6.	113CX	SEAL ASSEMBLY	1
7.	1004-1X	SEAL HOUSING, STEEL (EXCEPT TFE O-RINGS)	1
	1004-11X	SEAL HOUSING, STAINLESS STEEL (EXCEPT TFE O-RINGS)	1
	1004-2X	SEAL HOUSING, STEEL (FOR TFE O-RINGS ONLY)	1
	1004-21X	SEAL HOUSING, STAINLESS STEEL (FOR TFE O-RINGS ONLY)	1
8.	1013	HOUSING ADJ. SHIM (.010)	As Req.
	1013-1	HOUSING ADJ. SHIM (.020)	As Req.

REF. NO.	PART NO.	PART NAME	QTY.
(a) 9.	2-224	O-RING (HOUSING)	1
10.	3442	PIPE PLUG 1/4" NPT	1
11.	3444	PIPE PLUG 3/4" NPT	1
12.	1002-09	CASE (MODEL 9)	1
	1002-0	CASE (MODEL 10)	1
	1002-2	CASE (MODEL 12)	1
	1002-3	CASE (MODEL 13)	1
	1002-4	CASE (MODEL 14)	1
	1002-5	CASE (MODEL 15)	1
	4206-09	CASE ANSI FLANGED (MODEL 9)	1
	4206-0	CASE ANSI FLANGED (MODEL 10)	1
	4206-2	CASE ANSI FLANGED (MODEL 12)	1
	4206-3	CASE ANSI FLANGED (MODEL 13)	1
	4206-4	CASE ANSI FLANGED (MODEL 14)	1
	4206-5	CASE ANSI FLANGED (MODEL 15)	1
13.	1914-1	NAMEPLATE	1
14.	7012-006SF025E	PHILLIP HD. 6-32 X 1/4"	2
15.	5002-281	BEARING RETAINER RING	1
16.	1238	BEARING CAP	1
17.	1006	GREASE SEAL	1
18.	5102-118	BEARING RETAINER RING	1
19.	2758	BALL BEARING (Was 55605)	1
20.	5000-281	BEARING RETAINER RING	1
21.	2497	#5 WOODRUFF KEY STEEL	1
	2497-1	#5 WOODRUFF KEY STAINLESS STEEL	1
22.	1234	SHAFT	1
	1234-1	SHAFT STAINLESS STEEL	1
23.	3226	KEY	1
24.	2759	BALL BEARING (Was 77506)	1
25.	1010-2	FRAME	1
26.	7002-037NC087A	SOC HEAD SCREW	4
27.	2158	GREASE ZERK	2
28.	2159	LUBRICAP	2

NOTE:

(a) Included with Seal Assy 113-CX. See Page F202. For Seal and O-Ring Material Coding See Page A500.

Spare Parts with Exploded View

PARTS DETAILS CORO-FLO PUMPS MODELS DS & DL

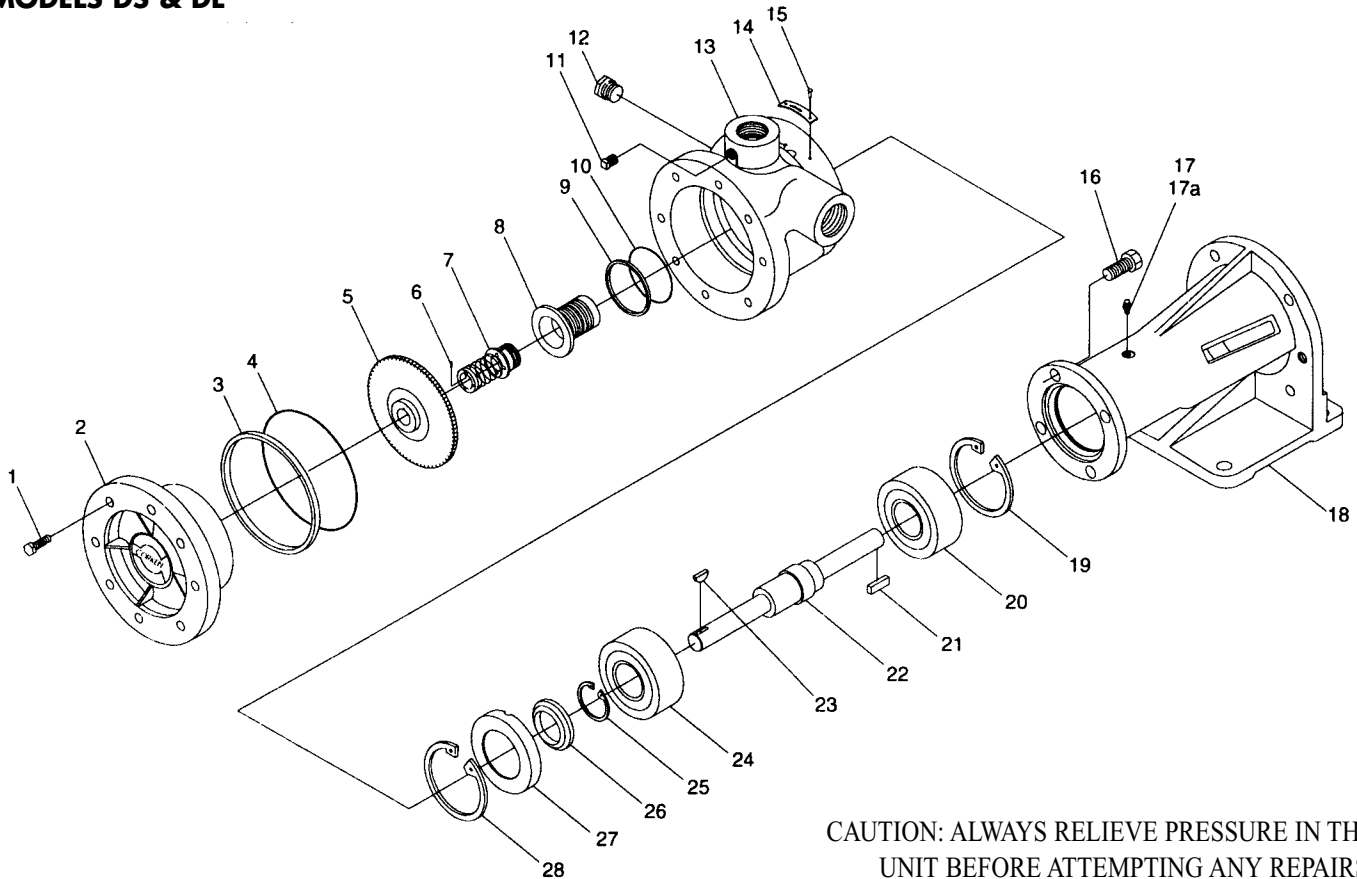

CAUTION: ALWAYS RELIEVE PRESSURE IN THE UNIT BEFORE ATTEMPTING ANY REPAIRS.

REF. NO.	PART NO.	PART NAME	QTY.
1.	7001-031NC100A	HEX HEAD CAP SCREW	8
2.	1001-09	COVER (MODEL 9)	1
	1001-0	COVER (MODEL 10)	1
	1001-2	COVER (MODEL 12)	1
	1001-3	COVER (MODEL 13)	1
	1001-4	COVER (MODEL 14)	1
	1001-5	COVER (MODEL 15)	1
(a) 3.	1014	CASE CLEARANCE SHIM (.002" RED)	As Req.
(a)	1014-1	CASE CLEARANCE SHIM (.003" GREEN)	As Req.
(a) 4.	2-246	O-RING (CASE) (EXCEPT TFE)	1
(a)	2-247E	O-RING (CASE) (TFE)	1
5.	1003-09	IMPELLER BRASS	
	1003-091	IMPELLER IRON (MODEL 9)	1
	1003-092	IMPELLER STAINLESS STEEL	
	1003-0	IMPELLER BRASS	
	1003-01	IMPELLER IRON (MODEL 10)	1
	1003-02	IMPELLER STAINLESS STEEL	
	1003-2	IMPELLER BRASS	
	1003-21	IMPELLER IRON (MODEL 12)	1
	1003-22	IMPELLER STAINLESS STEEL	
	1003-3	IMPELLER BRASS	
	1003-31	IMPELLER IRON (MODEL 13)	1
	1003-32	IMPELLER STAINLESS STEEL	
	1003-4	IMPELLER BRASS	
	1003-41	IMPELLER IRON (MODEL 14)	1
	1003-42	IMPELLER STAINLESS STEEL	
	1003-5	IMPELLER BRASS	
	1003-51	IMPELLER IRON (MODEL 15)	1
	1003-52	IMPELLER STAINLESS STEEL	
(a) 6.	1009	SEAL PIN	1
7.	113CX	SEAL ASSEMBLY	1
8.	1004-1X	SEAL HOUSING, STEEL (EXCEPT TFE O-RINGS)	1
	1004-11X	SEAL HOUSING, STAINLESS STEEL (EXCEPT TFE O-RINGS)	1

REF. NO.	PART NO.	PART NAME	QTY.	
	1004-2X	SEAL HOUSING, STEEL (FOR TFE O-RINGS ONLY)	1	
	1004-21X	SEAL HOUSING, STAINLESS STEEL (FOR TFE O-RINGS ONLY)	1	
9.	1013	HOUSING ADJ. SHIM (.010)	As Req.	
(a) 10.	1013-1	HOUSING ADJ. SHIM (.020)	As Req.	
	2-224	O-RING (HOUSING)	1	
	11.	3442	PIPE PLUG 1/4" NPT	1
	12.	3444	PIPE PLUG 3/4" NPT	1
13.	1002-09	CASE (MODEL 9)	1	
	1002-0	CASE (MODEL 10)	1	
	1002-2	CASE (MODEL 12)	1	
	1002-3	CASE (MODEL 13)	1	
	1002-4	CASE (MODEL 14)	1	
	1002-5	CASE (MODEL 15)	1	
14.	1914-1	NAMEPLATE		
15.	7012-006SF025E	PHILLIP HD. 6-32 X 1/4"	2	
16.	7001-037NC100A	PUMP HEX. HD. MOUNTING BOLTS	4	
17.	2158	GREASE ZERK 1/8" NPT	2	
17a.	2159	LUBRICAP	2	
18.	4298	MOUNTING FRAME - DL	1	
	4308	MOUNTING FRAME - DS		
19.	5000-281	RETAINER RING	1	
20.	4378	BEARING	1	
21.	3226	KEY	1	
22.	4303	SHAFT	1	
23.	2497	#5 WOODRUFF KEY STEEL	1	
	2497-1	#5 WOODRUFF KEY STAINLESS STEEL	1	
24.	2758	BEARING	1	
25.	5102-118	RETAINER RING	1	
26.	1006	GREASE SEAL	1	
27.	1238	BEARING CAP	1	
28.	5002-281	RETAINER RING	1	

NOTE:

(a) Included with Seal Assy 113-CX.

Technical Service Manual

CORO-FLO® SERIES

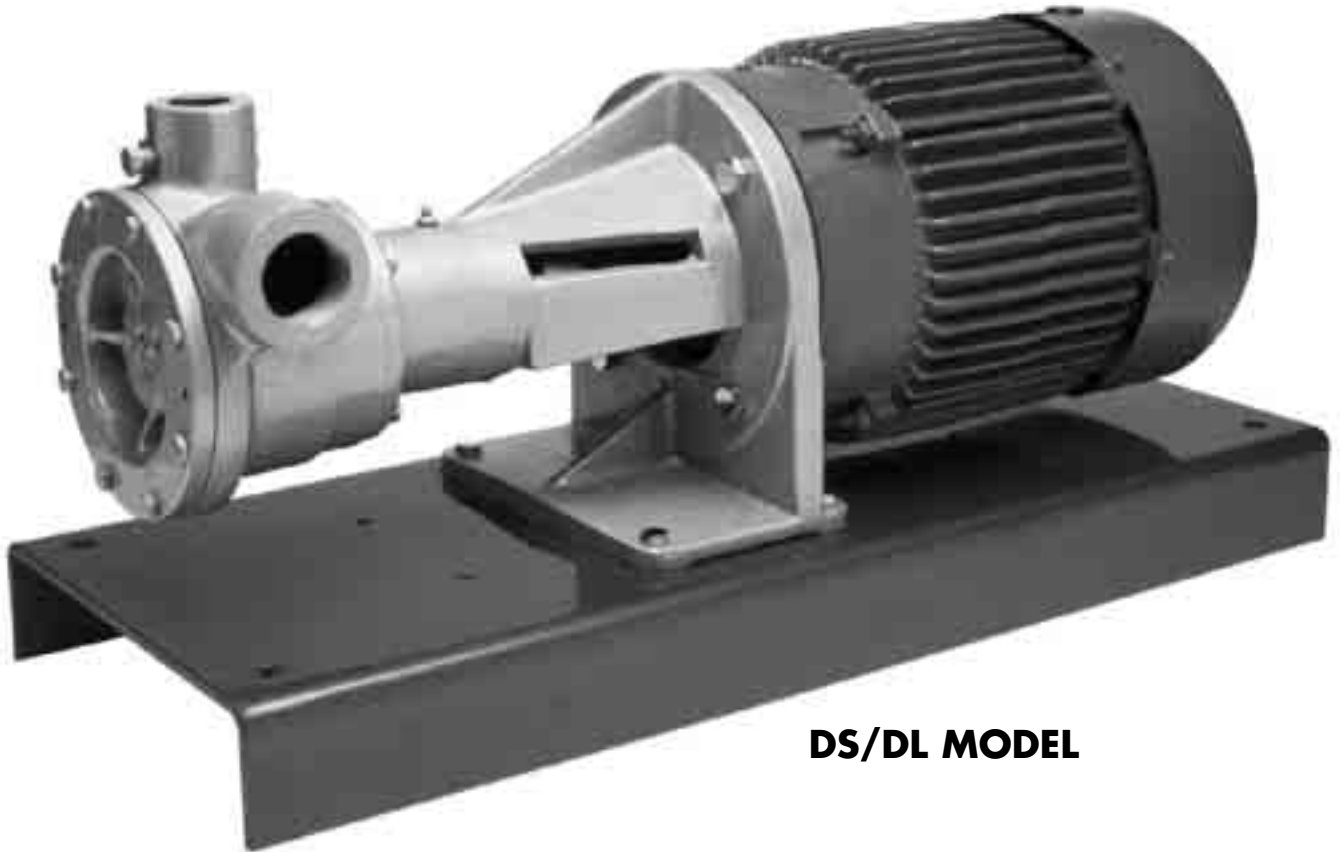

DS/DL MODEL

CORKEN[®]
IDEX

Warning: (1) Periodic inspection and maintenance of Corken products is essential. (2) Inspection, maintenance and installation of Corken products must be made only by experienced, trained and qualified personnel. (3) Maintenance, use and installation of Corken products must comply with Corken instructions, applicable laws and safety standards (such as NFPA Pamphlet 58 for LP-Gas and ANSI K61. 1-1972 for Anhydrous Ammonia). (4) Transfer of toxic, dangerous, flammable or explosive substances using Corken products is at user's risk and equipment should be operated only by qualified personnel according to applicable laws and safety standards.

PRINCIPLES OF THE CORKEN CORO-FLO® PUMP 36

EXCLUSIVE FEATURES OF YOUR CORKEN CORO-FLO® PUMP 36

INSTALLATION OF YOUR CORKEN CORO-FLO® PUMP 36

 Inlet Piping Should Include the Following 37

 Outlet Piping Should Include the Following 37

 By-Pass System Must Include the Following 37

 Pump Foundation F-Models 37

 Level Base 38

 Coupling Alignment F-Models 38

 Back-Up Wrench 38

 Driver Installation 38

COMMON INSTALLATION 39

OPERATION OF YOUR CORO-FLO® PUMP 40

CARE OF YOUR CORO-FLO® PUMP 40

REPAIR SERVICE ON YOUR CORO-FLO® PUMP 40

PRINCIPLES OF THE CORKEN CORO-FLO® PUMP

The CORKEN Coro-Flo Pump is a special type of pump known as a turbine or regenerative pump. The liquid flows into the inlet nozzle and into the passageway on each side of an impeller (the rotating element) and is recirculated constantly between the vanes or teeth of the impeller and this passageway as the impeller rotates. The fluid makes a complete revolution in the pump case and is diverted out the outlet nozzle. The horsepower required to drive the pump increases as the differential pressure increases, but the capacity decreases at the same time. (Differential pressure is the difference between the pressure at the inlet of the pump and at the outlet of the pump.)

The impeller is the only moving part and has no contact with the casing. Consequently, practically no wear occurs to the impeller, even when pumping volatile liquids such as LP-gas or ammonia which have no lubricating qualities.

EXCLUSIVE FEATURES OF YOUR CORKEN CORO-FLO® PUMP

The pumping of volatile liquids is one of the most difficult of all pumping jobs. Unlike other pumping operations, more attention must be given to the design, manufacture installation and operation of the pump.

In addition to being a pump type especially suited for handling volatile liquids, your CORO-FLO PUMP has a number of features which help to make it more easily operated and maintained.

The CORO-FLO PUMPS of this series are manufactured with their own frame for connection to a separate driver by means of a flexible coupling. The frame pumps are available in the F- and DS/DL-models with the following pump sizes: 9, 10, 12, 13, 14 and 15.

UNDERWRITERS' LABORATORIES, INC. have tested and inspected the CORO-FLO PUMPS of this series and have listed them for use in the handling of LP-gas and ammonia fluids. The nameplate on the pump shows the UL label.

DUCTILE IRON, the metal with the strength of steel, has been used in the manufacture of this pump for parts under pressure of the liquid.

THE IMPELLER floats on a shaft and may be replaced easily without disturbing the piping or driver by simply removing the cover. No special tools are needed.

THE MECHANICAL SEAL ASSEMBLY may be replaced easily by removing the cover and the impeller, and without disturbing the piping or driver. No special tools are needed.

THE PUMP NOZZLES MAY BE ROTATED into four different positions, 90 degrees apart, if desired.

A BYPASS CONNECTION, 3/4" pipe thread, has been located on the outlet nozzle to make the piping of the pump more simple.

PRESSURE GAUGE CONNECTIONS, 1/4" pipe thread, have been located on the outlet nozzle.

INSTALLATION OF YOUR CORKEN CORO-FLO® PUMP

THE INSTALLATION OF A CORO-FLO PUMP is a simple matter. However, in order for the pump to deliver the performance you expect, the principles discussed in this book must be followed exactly. The piping details are furnished to illustrate methods proved by hundreds of installations. Your own needs may require some slight variations, but they must be slight, and no compromise made.

For more detailed piping arrangements, request Engineering Data book Z400. For a discussion of pumping from underground tanks see Corken Engineering Bulletin #6.

IF IT IS DESIRABLE TO ROTATE THE NOZZLES of the pump to a new position, remove the four cap screws connecting the pump case to the frame. Be careful to do this without moving the case away from the frame; otherwise, the mechanical seal may be damaged.

NO PUMP CAN DISCHARGE MORE LIQUID THAN IT RECEIVES, so the location and the inlet piping must be given careful attention. If the inlet piping is inadequate to supply the demand of the pump, you may expect trouble!

THE PUMP MUST BE LOCATED AS NEAR THE STORAGE TANK as possible. The complete inlet line, including the vertical line from the tank must not exceed 12 feet in length. The bottom of the tank must be at least two feet above the pump inlet nozzle, and four feet should be considered standard.

THE INLET SHOULD INCLUDE THE FOLLOWING:

1. The tank excess flow valve should have a flow rate of 1-1/2 to 2 times the capacity of the pump. Do not use an EVF without knowing its flow capacity.
2. The tank shutoff valve should be an angle valve or a free flow type – not a standard globe valve.
3. A strainer of the "Y" type, with 1/16" mesh screen, must be on the inlet line of the pump. For simpler inlet lines use a Corken 1836-X1 Right Angle Strainer to replace an elbow and "Y" strainer.
4. A flexible connection should be used on the pump inlet or outlet to care for piping strains.
5. Unions must be installed near the pump inlet and outlet nozzles.
6. An eccentric swage should be used at the pump inlet nozzle to change line size (flat side up.)
7. The inlet line must be level or slope downward to the pump.
8. The minimum inlet piping sizes must be observed.

THE OUTLET PIPING SHOULD INCLUDE THE FOLLOWING:

1. A pressure gauge should be installed in the opening provided on the outlet nozzle or in the outlet piping near the pump. This pressure gauge will tell you the complete story of the operation inside your pump. Be sure you have one installed.
2. A hydrostatic relief valve is required to be installed in the outlet piping.
3. If the outlet piping exceeds 50 feet in length, a check valve should be installed near the pump outlet.

THE BYPASS SYSTEM MUST INCLUDE THE FOLLOWING:

1. The pump bypass system must be installed. Without this system, the pump has little chance of performing.
2. A CORKEN B166 BYPASS VALVE (a special valve to vent the pump of vapors and to act as a differential relief valve) makes the ideal installation.
3. The bypass line must rise uninterrupted to an opening in the

vapor section of the storage tank. The tank fitting must be either an excess flow valve or a vapor return valve; it should never be a filler valve or a back check valve.

PUMP FOUNDATION F-MODELS

Every pump deserves a firm, neat concrete foundation. There are many ways to construct a foundation, and the example in Figure 3 is only a suggestion. The important features are to make the foundation level, and deep enough to get below the frost line for your locality.

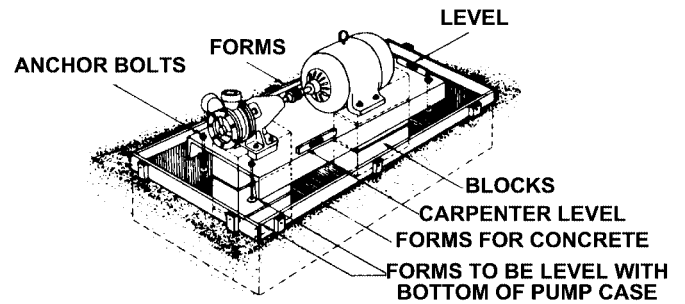

Figure 3

LEVEL BASE

After the concrete has set, check the pump base for level. Drive metal shims under the base near the anchor bolts as below. Tighten anchor bolts and recheck the base for level.

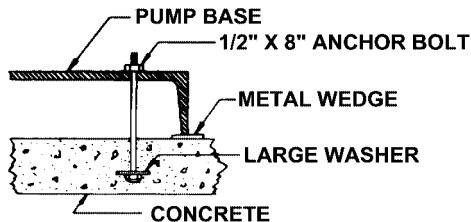

Figure 4

COUPLING ALIGNMENT F-MODELS

The coupling alignment must be near perfect to give quiet, long-life service to the pump and driver. The pump and driver shafts are carefully aligned at the factory but always should be checked after the pump is installed and before the initial operation.

Lay a straight edge across coupling halves, top, and side; both positions must line up to be correct.

If misalignment exists, adjust the shims between the pump base and the foundation until exact alignment is accomplished.

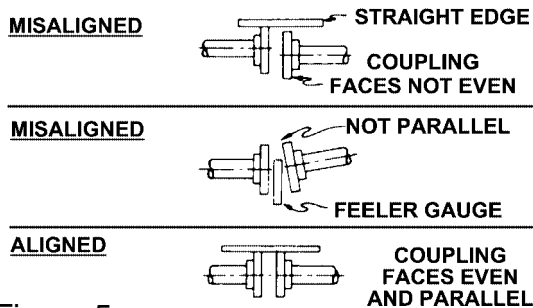

Figure 5

BACK-UP WRENCH

To keep from breaking the pump nozzle or springing the pump out of alignment, always use a back-up wrench as shown in Figure 6.

Use the proper wrench size, and be sure the pipe threads are clean and well doped with the proper thread seal for the service. Avoid using excessive dope, for it may enter the pump and damage the mechanical seal.

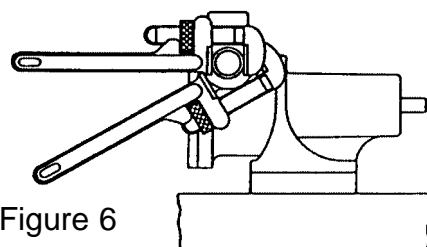

Figure 6

DRIVER INSTALLATION

THE WIRING OF YOUR ELECTRIC MOTOR is extremely important and must be done by a competent electrical contractor.

Improper motor wiring will cause you to experience expensive motor difficulties from low voltage. If you suspect you have low voltage, call your power company. Connecting your motor for the voltage you have available is important too. Be sure your motor is connected to the proper voltage. Connecting to improper voltage will completely destroy your motor.

In explosion-proof motor applications in humid climates, the normal breathing and alternating temperatures of the motor (warm during operation and cold when stopped) will often cause moist air to be drawn into the motor housing. This moist air will condense and may eventually add enough free water to the inside of the motor to cause it to fail. To prevent this, make a practice of running the motor and pump at least once a week on a bright, dry day for an hour or so (pump through the bypass system). During this time, the motor will heat up and vaporize the condensed moisture. No motor manufacturer will guarantee his explosion-proof or totally enclosed motor against damage from moisture.

ENGINE DRIVERS pose a special consideration. The manufacturer's instructions must be followed. When the CORO-FLO PUMP is equipped with an engine from the factory, the engine speed should normally not exceed 3600 rpm. Excessive engine speed will overload the engine and cause early failure. The engine loses 3% of its power for every 1000 feet above sea level, so if your installation is at a higher altitude than normal, consult the factory.

VAPOR LINE FROM METER
VAPOR ELIMINATOR OR
METER BACK PRESSURE VALVE

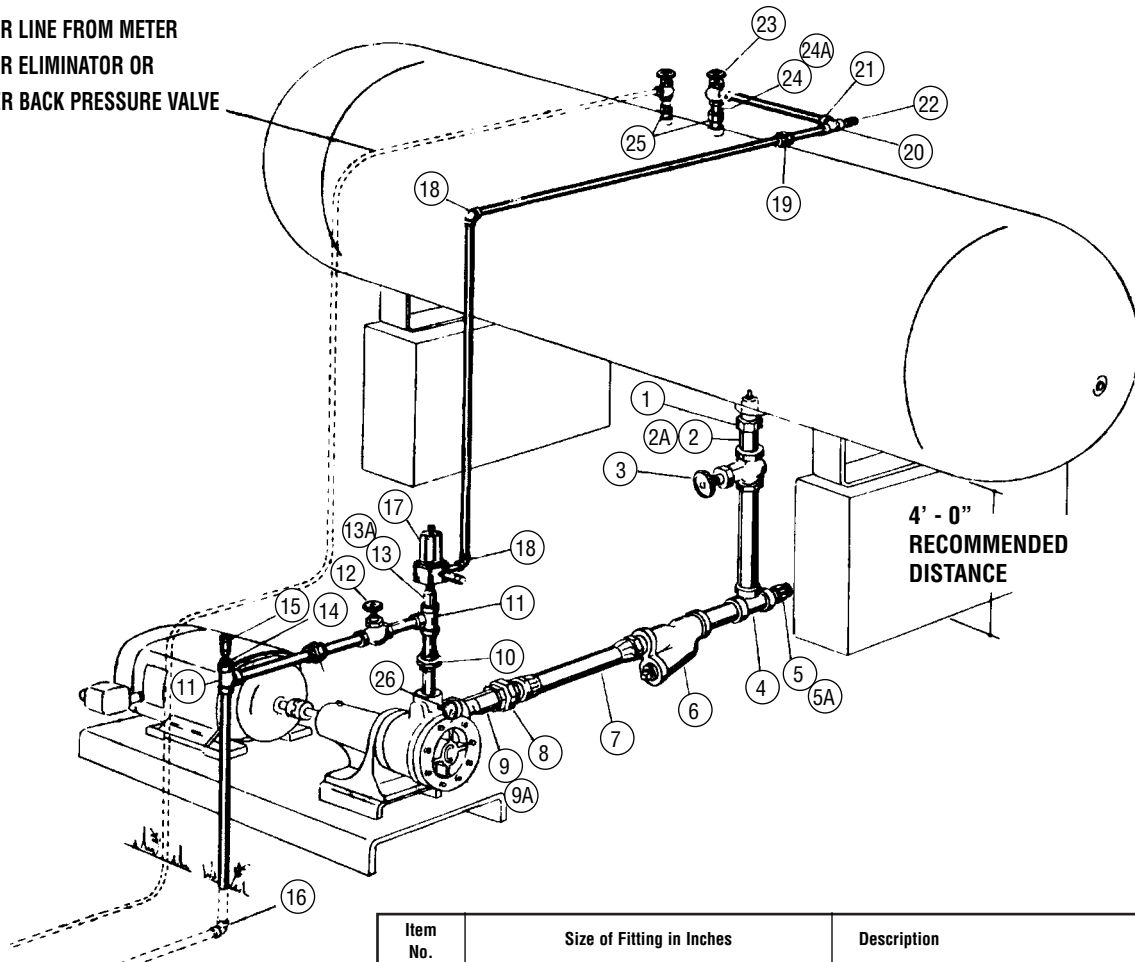

IF DISCHARGE LINE IS OVER 50 FEET LONG, INSTALL A CHECK VALVE BETWEEN VALVE 15 AND TEE 16.

Item No.	Size of Fitting in Inches			Description
	Model C10 F9, F10	Model C12, C13 F12, F13	Model C14 F14	
1	1-1/4	2	2	Excess Flow Valve
2	1-1/4	---	2	Nipple
2A	---	2 x 1-1/2	---	Swage Nipple
3	1-1/4	1-1/2	2	Shutoff Valve
4	1-1/4	1-1/2	2	Tee
5	1-1/4	1-1/4	2	Double Check Filler Valve
5A	---	1-1/2 x 1-1/4	---	Bushing
6	1-1/4	1-1/2	2	Strainer with 1/16 Mesh Screen
7	1-1/4	1-1/2	2	Flexible Hose Connection with Male Hose Connection
8	1-1/4	1-1/2	2	Union
9	1-1/4	1-1/2	---	Nipple
9A	---	---	2 x 1-1/2	Swage Nipple
10	1	1	1	Union
11	1	1	1	Tee
12	1	1	1	Shutoff Valve
13	1 x 3/4	1 x 3/4	---	Swage Nipple
13A	---	---	1	Nipple
14	1 x 1/2	1 x 1/2	1 x 1/2	Bushing
15	1/2	1/2	1/2	Hydrostatic Relief
16	1	1	1	Ell
17	3/4	3/4	1	Corken Bypass Valve B-166
18	3/4	3/4	1	Ell
19	3/4	3/4	1	Union
20	3/4	3/4	1	Tee
21	---	---	1 x 3/4	Swage Nipple
22	3/4	3/4	3/4	Vapor Return Valve
23	3/4	3/4	1	Angle Valve
24	3/4	3/4	---	Nipple
24A	---	---	1 x 3/4	Swage Nipple
25	3/4	3/4	3/4	Excess Flow Valve
26	1/4	1/4	1/4	Pressure Gauge with 1/4" x 2" Nipple and 1/4" 90° Ell

OPERATION OF YOUR CORO-FLO® PUMP

The following steps should be performed for the initial pumping operation:

1. Close the shutoff valve on the end of the delivery hose.
2. Open the storage tank bottom shutoff valve.
3. Open the storage tank shutoff valve of the bypass system.
4. Check the motor for the proper voltage. (See instructions under driver installation.)
5. Start the pump and circulate liquid through the bypass system.
6. Adjust the B166 bypass valve by turning the adjusting screw out until the pump pressure gauge shows nearly the same pressure it did before you started the pump. Screw the adjusting screw in until the pressure gauge indicates the pump is starting to lose discharge pressure (you will know this by the rapid fluctuating of the pointer); then back the adjusting screw out a turn or two until the pressure gauge again indicates a steady pressure. Lock the lock nut, and permit the pump to circulate liquid for a half hour or more. If the motor overload protection device stops the motor during this period, this indicates the bypass system valve is set too high and should be readjusted by turning the adjusting screw out until the motor will run for this period.

CARE OF YOUR CORO-FLO® PUMP

The only maintenance necessary on this pump is to lubricate the bearings about once every six months. The Bearings have been lubricated at the factory for the initial operation.

LUBRICATION FOR MODELS F9, F10, F12, F13, F14, F15, DS/DL 9, 10, 12, 13, 14, AND 15

There are two bearings on the pump frame of these models that require lubrication. In addition, if the pump is driven by a motor there may be two bearings on the motor to lubricate at the same time you lubricate the pump bearings. If the driver is an engine, follow the engine manufacturer's instructions.

LUBRICATING BALL BEARING IS SIMPLE. Use only Ball Bearing Grease – nothing else will do. Remove the plug or fitting over the bearing, add a small amount of grease, and run the pump and driver for several minutes with the plug removed. The bearings will pump out the excess grease. Replace the plug.

REPAIR SERVICE ON YOUR CORO-FLO® PUMP

After a long service life, repairs are limited to replacing the impeller or mechanical seal.

The only wearing part influencing the pumping action is the impeller, so we suggest the pump be given an "efficiency" test before any attempt is made to repair it. The trouble may lie in the piping system rather than in the pump. If the pump will still produce as much differential pressure when circulating through the bypass system as it did when new, you may be sure your problem is elsewhere. If the pump does not produce as much pressure as it did originally, remove the cover and inspect the impeller. If visual inspection indicates the impeller is in good condition, remove the thin shim gasket and replace the cover. Many times this procedure will adjust for slight Impeller wear. If the Impeller is badly damaged, it must be replaced.

REPLACING THE IMPELLER is a matter of removing the cover and removing the old impeller from the shaft. If the old impeller is tight on the shaft, threaded bolt holes are provided in the impeller to use for pulling. The new impeller must be a good slip fit on the shaft; it should "float" on the shaft, so it may be necessary to sand the shaft lightly to get the proper fit.

REPLACING THE MECHANICAL SEAL is a simple matter, and replacement parts are immediately available. Clear instructions are furnished with the replacement seal assembly for its installation.

Technical Service Manual

SEAL REPLACEMENT



CORKEN[®]
IDEX

Warning: (1) Periodic inspection and maintenance of Corken products is essential. (2) Inspection, maintenance and installation of Corken products must be made only by experienced, trained and qualified personnel. (3) Maintenance, use and installation of Corken products must comply with Corken instructions, applicable laws and safety standards (such as NFPA Pamphlet 58 for LP-Gas and ANSI K61. 1-1972 for Anhydrous Ammonia). (4) Transfer of toxic, dangerous, flammable or explosive substances using Corken products is at user's risk and equipment should be operated only by qualified personnel according to applicable laws and safety standards.

Technical Service Manual / Seal Replacement

CAUTION

Bleed all pressure from the pump and piping before starting to install your seal assembly.

CLEANLINESS

Even the smallest amount of dirt on your new seal can cause early failure. Keep all parts, tools and your hands clean while installing the seal. Never touch the smooth lapped faces of the carbon rotor or seal seat. For LP-gas, anhydrous ammonia and similar liquids, you are trying to seal a fluid that is 5 to 10 times thinner than water! Your new seal needs every chance it can get, so keep it clean.



1. Remove the cover cap screws and remove the cover from the case. If the cover is stuck, use two cover screws in the threaded holes to loosen it.



3. Remove the impeller key (No. 14; Figure 1) with side cutters or by tapping with a punch, forcing the key up and out of its slot. Take care not to damage the shaft.



5. Remove the pump nameplate. Through the exposed holes in the case, engage a screw driver in the grooves on the seal housing (No. 12) and pry the housing and seal sleeve from the pump chamber. Be sure to keep all of the shims (No. 13) with the housing so they will not be bent or lost.



2. Remove the impeller. It should slide freely, but if it is stuck use two cover cap screws in the threaded holes provided and pry off carefully. Care must be taken not to warp the impeller or damage the case o-ring groove.



4. Remove the three seal clamp ring screws (No. 1) and remove the seal clamp ring (No. 2). Using a screw driver, press against the seal sleeve (No. 5) and remove the seal drive pin (No. 15).



6. Carefully tap the old seal seat (No. 10) out of the seal housing. Do not damage the interior of the housing.



7. Clean the seal housing (No. 12) and apply a light coat of oil on the inside surfaces. Remove the new seal seat (No. 10) from its package and oil the seal seat o-ring (No. 11). Wipe the smooth lapped face clean, being very careful not to scratch it or leave any fingerprints on it. Insert the seal seat with the notch pointing down and in line with the locator pin in the back of the seal housing (No. 12). Place the small round piece of cardboard found in the seal package (being sure it is very clean) on the seal seat face. Use a hammer handle with cardboard disc to push the seal seat (No. 10) into place. Check to make sure the locator pin is in the seal seat notch.



8. Using a knife, remove the old seal housing o-ring groove and install a new o-ring after applying a thin coat of oil. Clean the shaft and remove any burrs

around the keyway. Replace all the shims (No. 13) on the seal housing (No. 12) and apply a light coat of oil to the outside surfaces. Reinstall the seal housing (No. 12) into the pump case.



9. Carefully unwrap the remainder of your seal assembly, which includes the new retainer shell (No. 6), carbon rotor (No. 9) and seal sleeve assembly (No. 5). Carefully wipe the carbon rotor clean with a soft cloth, being sure that it is not scratched. Apply a thin coat of oil to the carbon face and the o-ring behind the carbon. Slide the entire assembly in place on the shaft. Oil and insert the follower o-ring (No. 4) and the follower ring (No. 3). Make certain the follower ring is pointing out.



10. Align the notches in the seal sleeve (No. 5) and the follower ring (No. 3) with the small hole in the shaft. With a screw driver push the seal sleeve (No. 5) and the follower ring (No. 3) back in order to drop a new drive pin (No. 15) into the hole in the shaft. Install the clamp ring (No. 2).

11. Install the new impeller key (No. 14) by using pliers to squeeze the key in to the keyway slot. A small piece of cardboard should be used as a pad between the pliers and the shaft. The impeller must slide on the shaft very freely. If it is tight, carefully remove any burrs from the keyway or key with a small file. Be certain to clean all filings off of the impeller before reinstalling.



12. Replace the cover o-ring or any shims which may have been damaged during removal. To obtain proper clearance, remove shims one at a time until binding is noted, then reinstall one shim.

13. Replace the cover and nameplate and check to see if the pump will spin freely. If at all possible, pressurize the pump case with vapor first. After the pump has been pressurized with vapor, then allow liquid to slowly enter the pump.

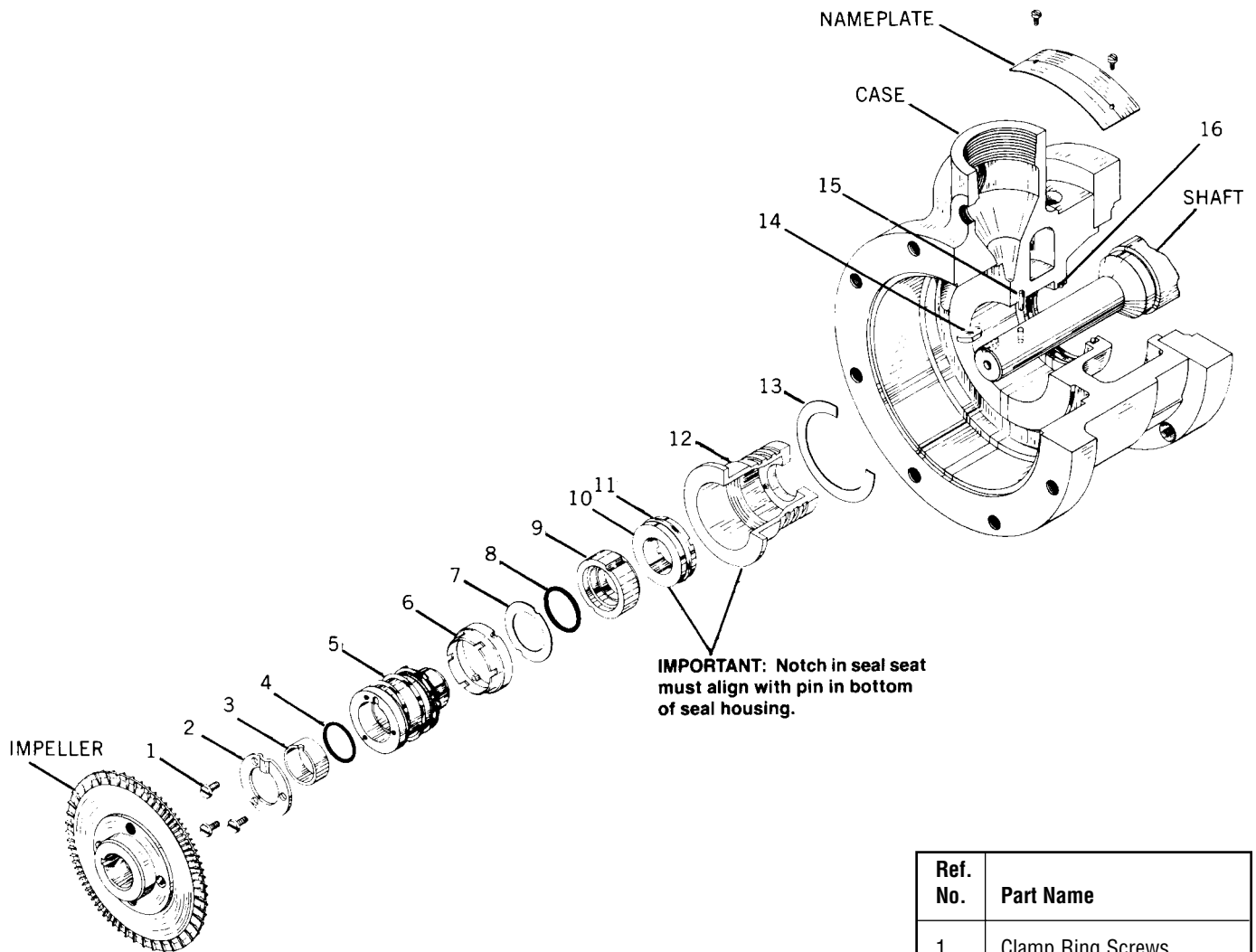

NOTE: These numbers are for general reference only and should not be used when ordering parts. Consult your Service Manual, Section F, for the correct part numbers for your pump model.

Ref. No.	Part Name
1	Clamp Ring Screws
2	Seal Clamp Ring
3	Follower Ring
4	Follower O-ring
5	Seal Sleeve Assembly
6	Retainer
7	Disc
8	Rotor O-ring
9	Rotor
10	Seal Seat
11	Seat O-ring
12	Seal Housing
13	Housing Adjustment Shim
14	Impeller Key
15	Drive Pin
16	Seal Housing O-ring

Bulk Transfer of Foam Blowing Agents

HIGHER FLOWS / BULK TRANSFER NEEDS

Although our niche focus is specific to low flow / high head applications, Corken's dynamic product offering covers a broad range of hydraulic conditions. Corken's Rotary Vane Pump product as well as high flow Side Channel product is specifically designed for high volume bulk transfer of liquefied gases and thin, non-lubricating liquids. We invite you to visit our web sight at www.corken.com, which provides more information on our entire product offering.

FLOW VS. PRESSURE

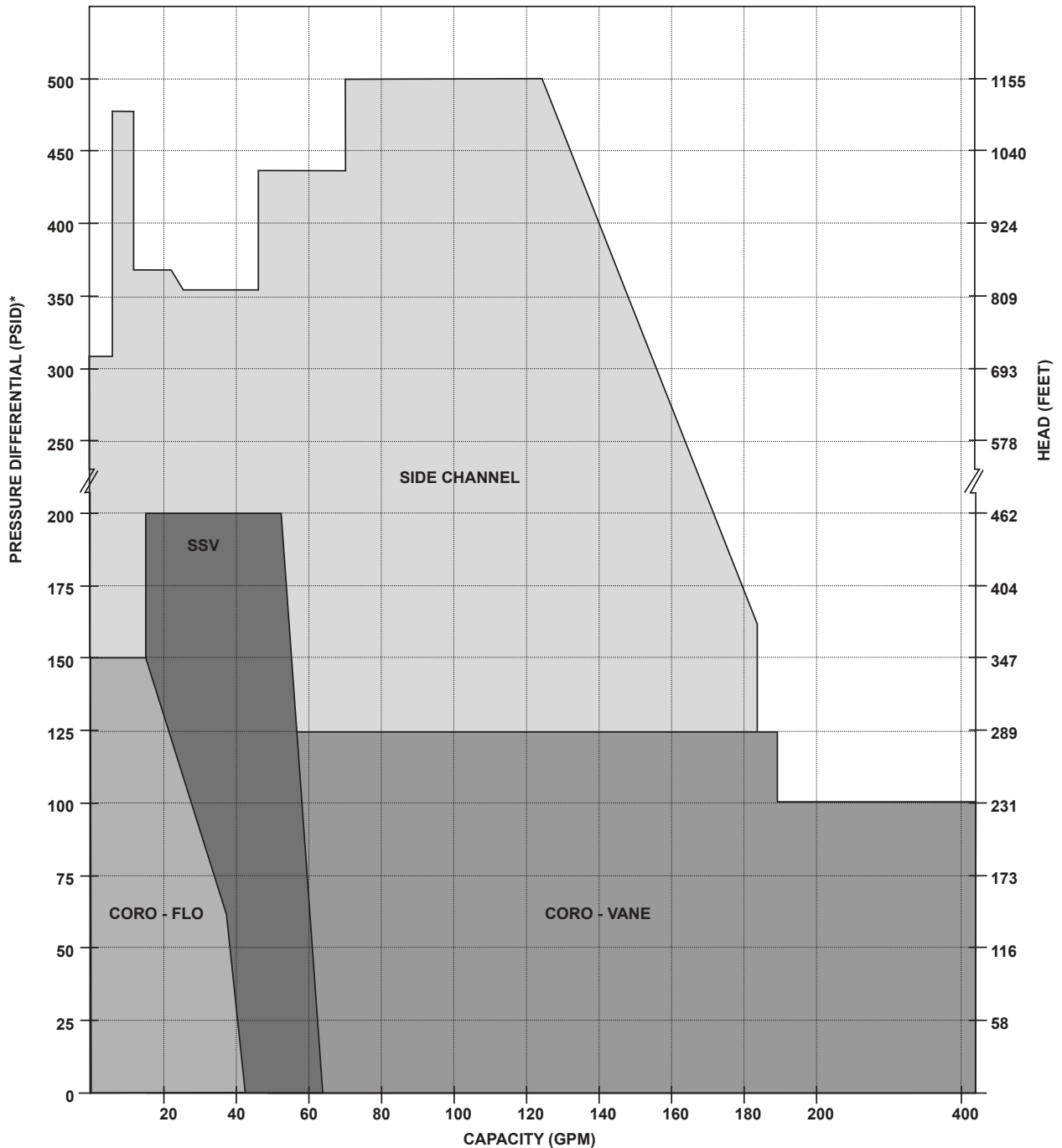

Common Blowing Agent Liquid List

FLUOROCARBONS

HCFC 141b
HCFC 142b
HCFC 22
HFC 245 FA
HFC 134 A
HFC 152 A

HYDROCARBONS

Isopentane
Cyclopentane
Pentane
Butane
Isobutane

CO₂

Application Data Sheet

Company Name and Location _____
Submitted by _____
Date _____
Phone Number _____
FAX Number _____

PUMP

Liquid _____
Specific Gravity _____
Discharge Pressure _____ PSIG
Inlet Temperature _____ °F
Differential Pressure _____ PSIG
Viscosity _____
Flow Rate _____ GPM, M³/hr, LPM
NPSHA _____
Power Available _____ Phase _____ Hz _____ Voltage _____

APPLICATION SUMMARY

NOTES

End Use _____ End User _____

System Recommendations

PIPING

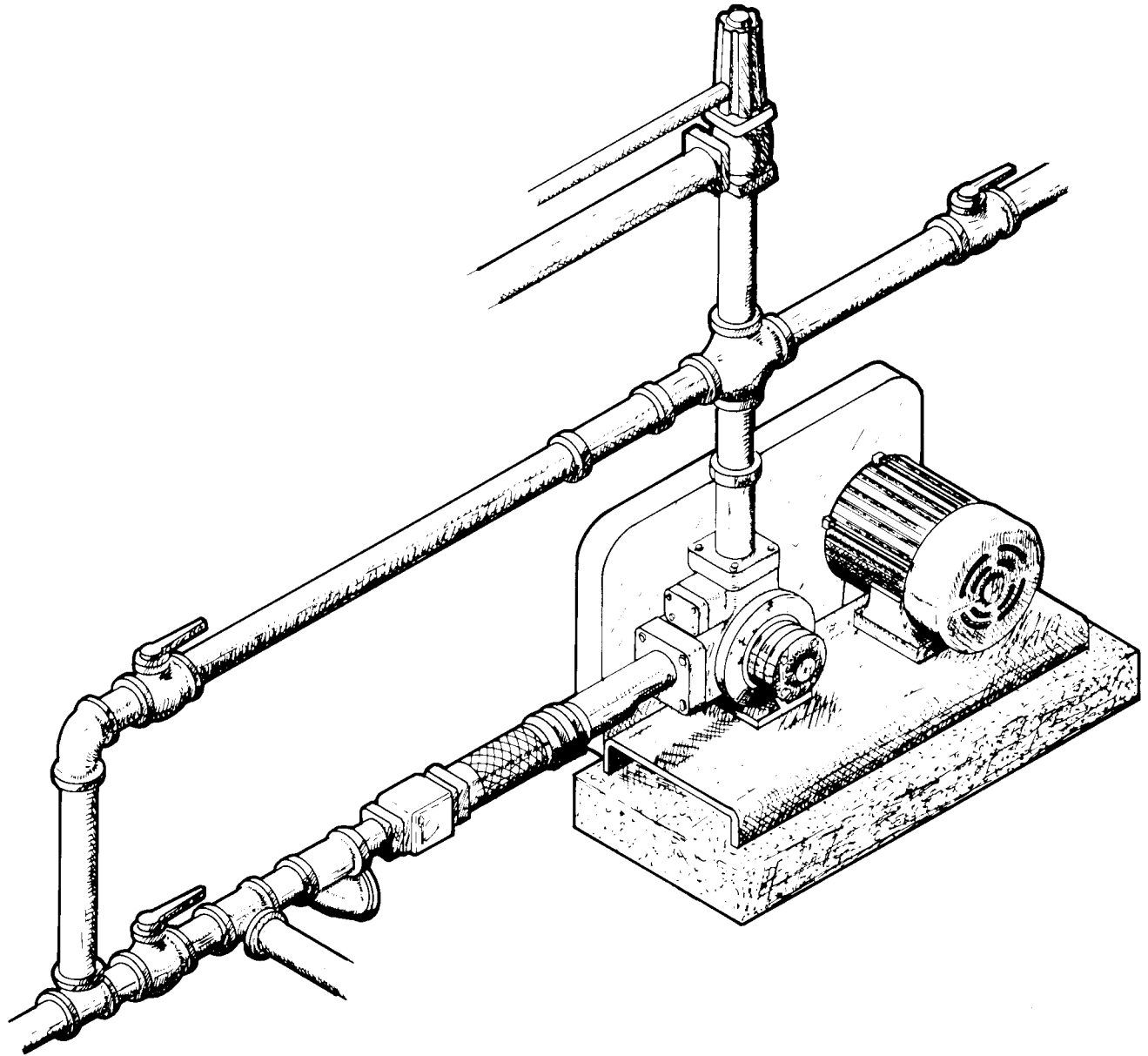

System Recommendations

PIPING

THE APPLICATION OF PUMPS TO LIQUEFIED GAS TRANSFER

Of the many hundreds of pump manufacturers in the United States, only a handful recommend their equipment for transferring liquefied gases. There are various reasons for this, but the basic problem has to do with the nature of a liquefied gas. The specific peculiarity of a liquefied gas is that a liquefied gas is normally stored at its boiling point ... exactly at its boiling point! This means that any reduction in pressure, regardless of how slight, or any increase in temperature, no matter how small, causes the liquid to start to boil. If either of these things happen in the inlet piping coming to the pump, the pump performance is severely affected. Pump capacity can be drastically reduced, the pump can be subjected to severe wear and the mechanical seal and the pump may run completely dry, causing dangerous wear and leakage.

Although we cannot change the nature of the liquefied gas, there are many things we can and must do to design an acceptable liquefied gas pumping system.

Many of these design hints are incorporated in the accompanying illustrations. You will note that each drawing is over-simplified and

illustrates just one principle. Normal fittings, strainers, unions, flex lines, valves, etc. have been ignored so that just that portion of the piping which applies to the problem is shown. Do not pipe a plant from these incomplete illustrations! You should also note that all of these rules can be violated to a degree and still have a workable pumping system. You may see several places where your plant is at variance from some of these. However, you should be aware that every violation is reducing your pumping efficiency and increasing your pump maintenance cost. The principles apply to all makes and styles of liquefied gas pumps ... rotary positive displacement, regenerative turbine or even centrifugal types.

This booklet is used in Corken Training Schools. Corken cooperates with gas marketers, trade associations and other groups to conduct complete training schools for persons involved in the transfer of liquefied gases. These presentations include product information, safety, plant design and equipment service / maintenance. Other information is available in various sections of your Corken Catalog.

Warning: (1) Periodic inspection and maintenance of Corken products is essential. (2) Inspection, maintenance and installation of Corken products must be made only by experienced, trained and qualified personnel. (3) Maintenance, use and installation of Corken products must comply with Corken instructions, applicable laws and safety standards (such as NFPA Pamphlet 58 for LP-Gas and ANSI K61. 1-1972 for Anhydrous Ammonia). (4) Transfer of toxic, dangerous, flammable or explosive substances using Corken products is at user's risk and equipment should be operated only by qualified personnel according to applicable laws and safety standards.

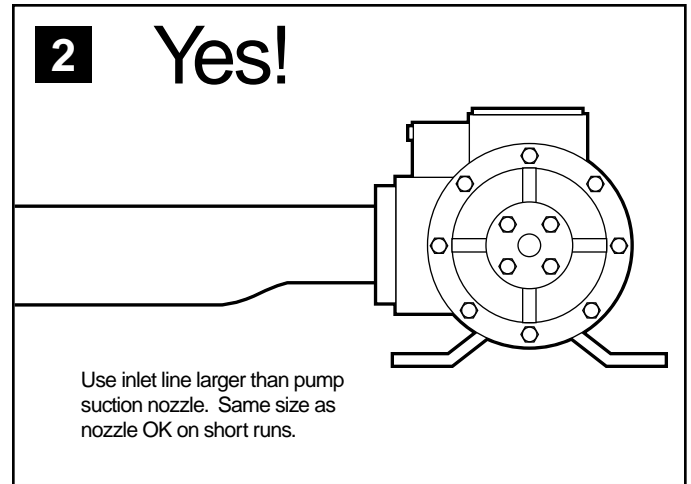
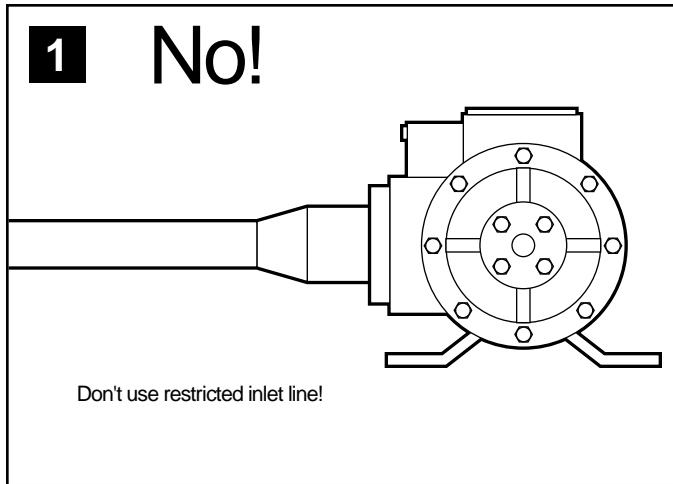

Pressure drop caused by restriction in suction line will cause vaporization and cavitation.

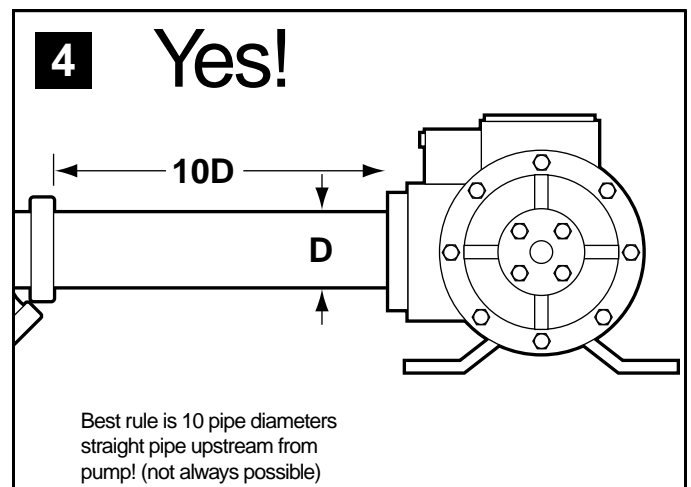
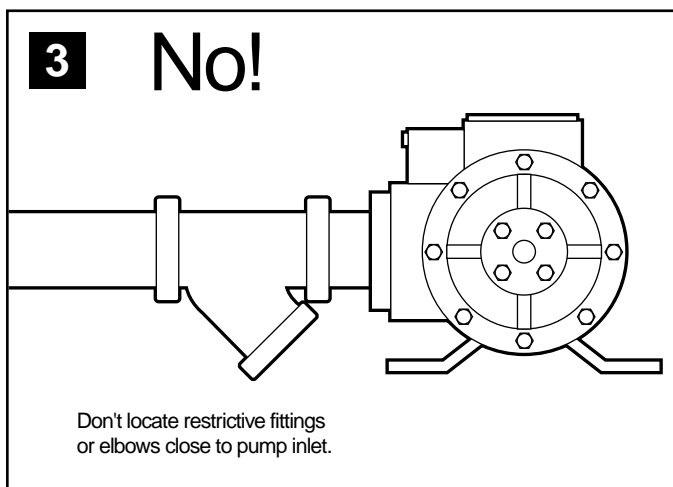

Turbulence caused by flow interference close to the pump accentuates incipient cavitation.

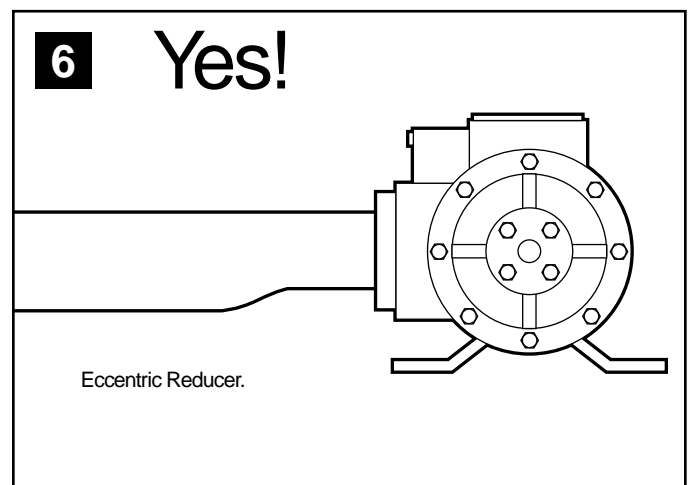
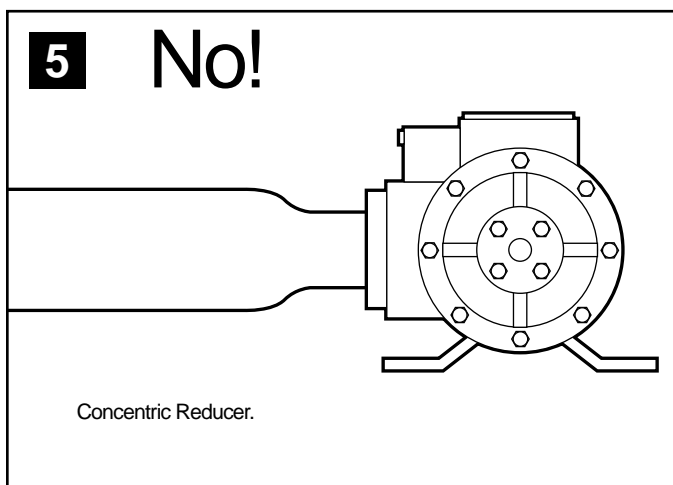

An eccentric reducer should always be used when reducing into any pump inlet where vapor might be encountered in the pumpage. The flat upper portion of the reducer prevents an accumulation of vapor that could interfere with pumping action.

System Recommendations

PIPING

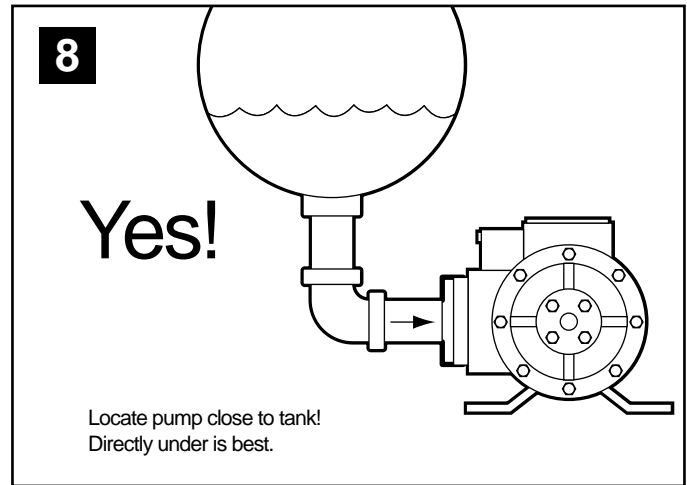
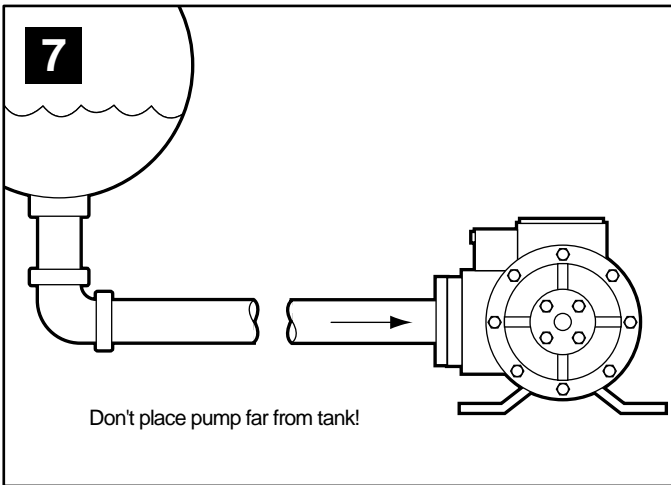

When possible, it is best to allow the pump to be fed by gravity flow to give stable, trouble-free operation.

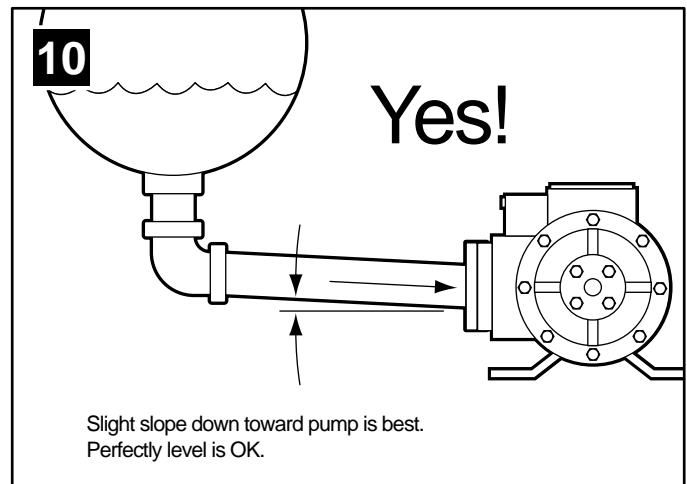
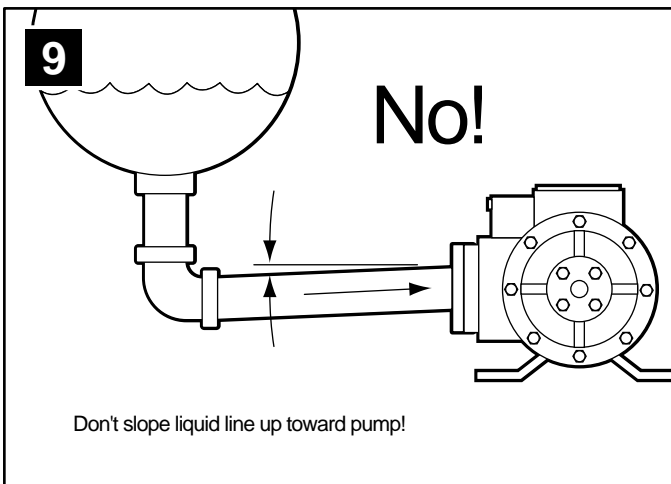

Vaporization in the pump inlet line can displace liquid in the pump so that pump may start up in a dry condition. A slope back toward the tank of only an inch or two in a 10 foot run will allow vapor to gravitate back into the tank and be replaced with liquid.

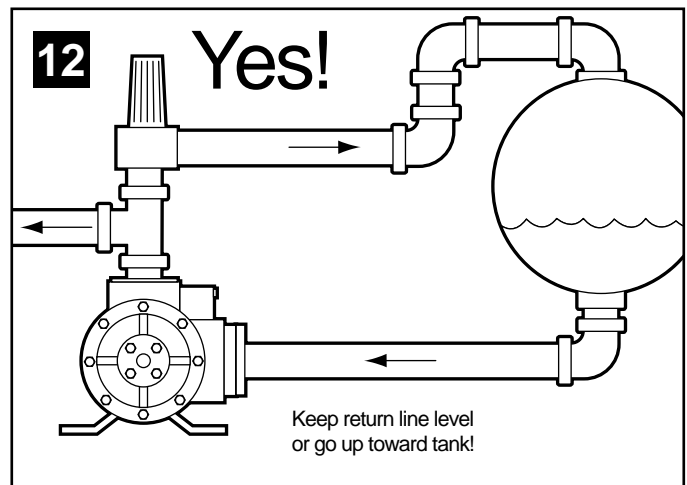
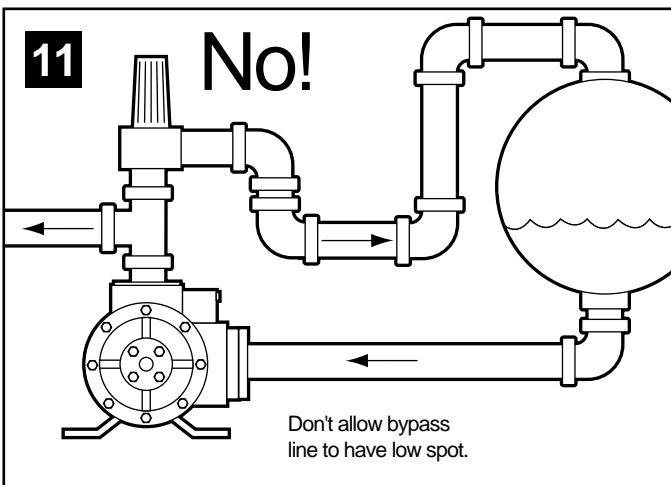

52 Low spots in bypass line can collect liquid which prevents normal vapor passage for priming purposes just like the P trap in the drain of a kitchen sink. This is not a problem for bypass lines where vapor elimination is not required.

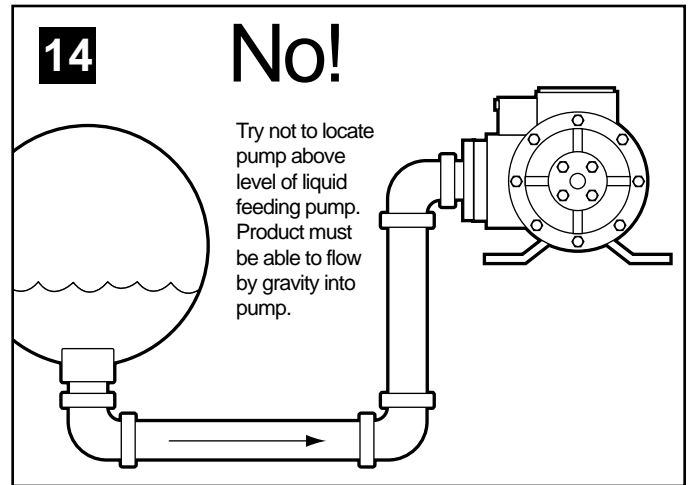
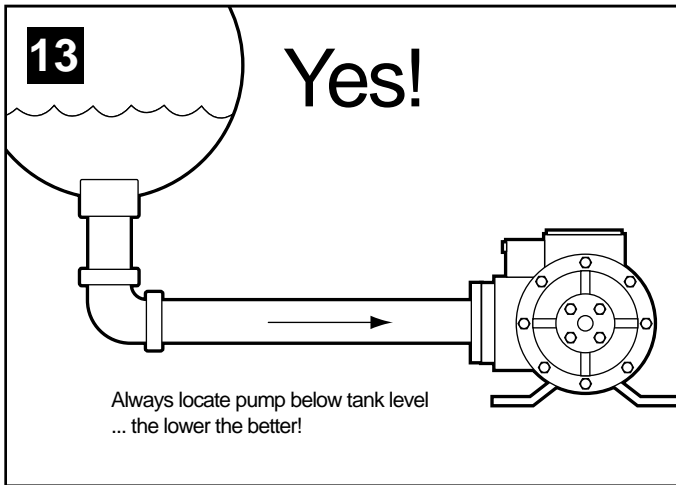

Since liquefied gases boil when drawn into a pump by its own suction, the pump must be fed by gravity flow to give stable, trouble-free operation.

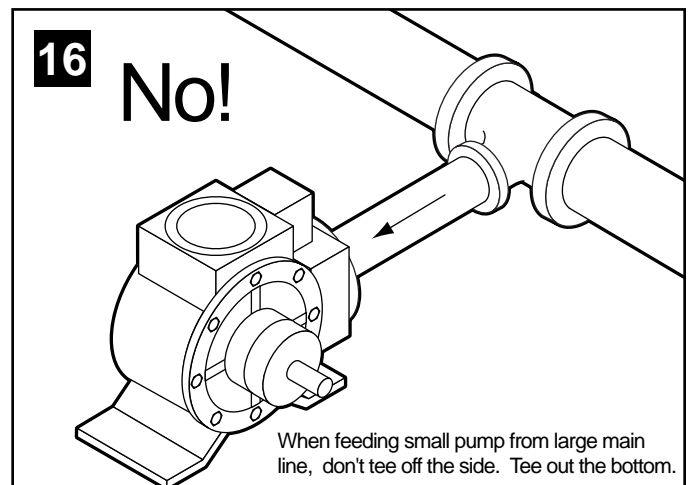
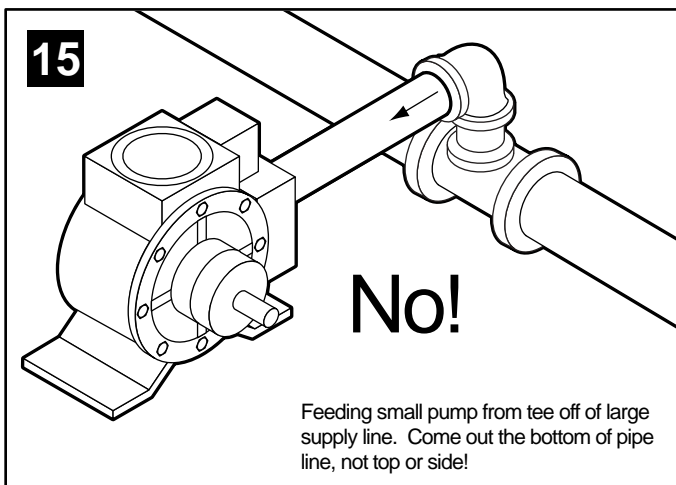

Low capacity flow through large lines often does not sweep out vapor. Flow occurs like liquid in a flume. Drawings 15 and 16 would allow vapor slugs to be drawn into the small pump causing erratic performance. Drawing 17 shows the best chance for stable feed into a small pump from a large line.

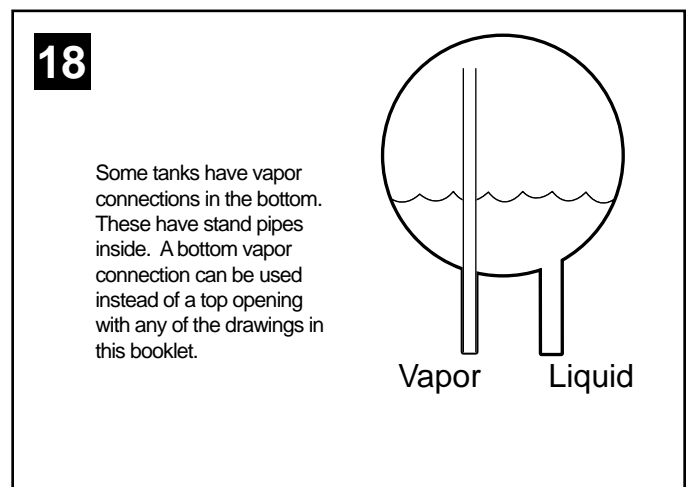
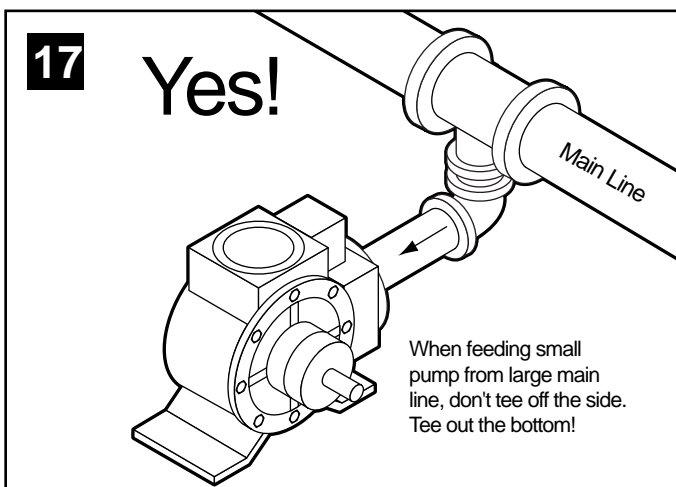

System Recommendations

PIPING

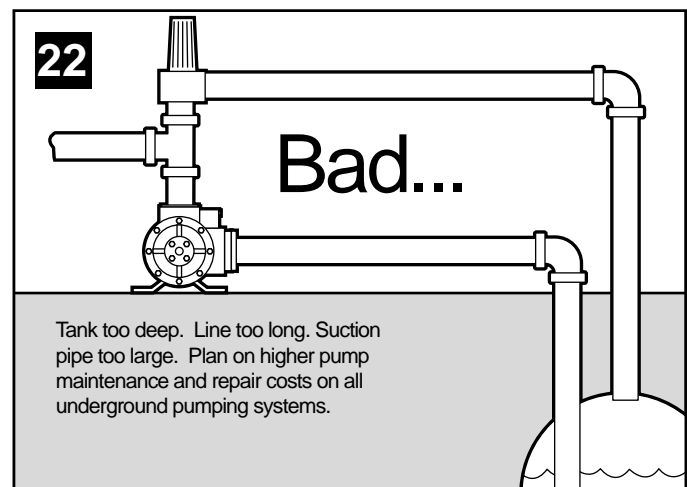
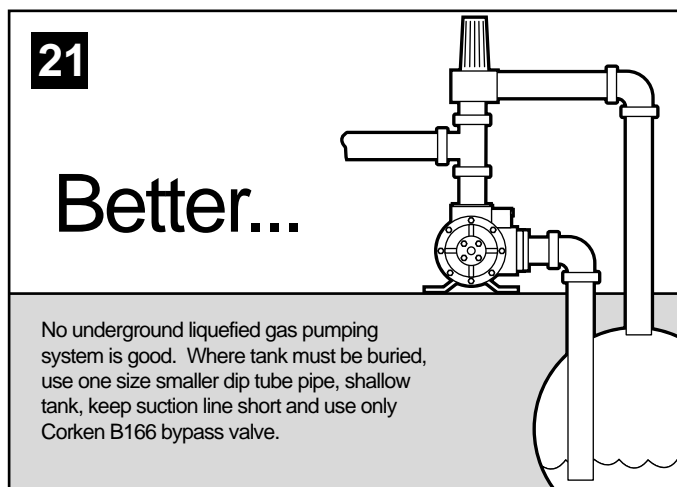
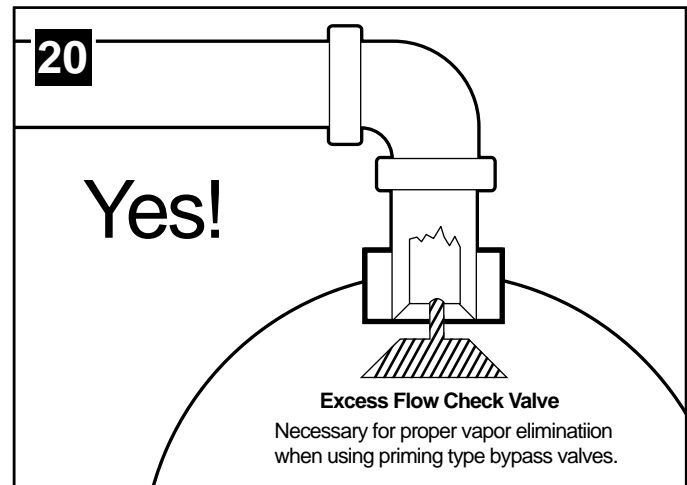
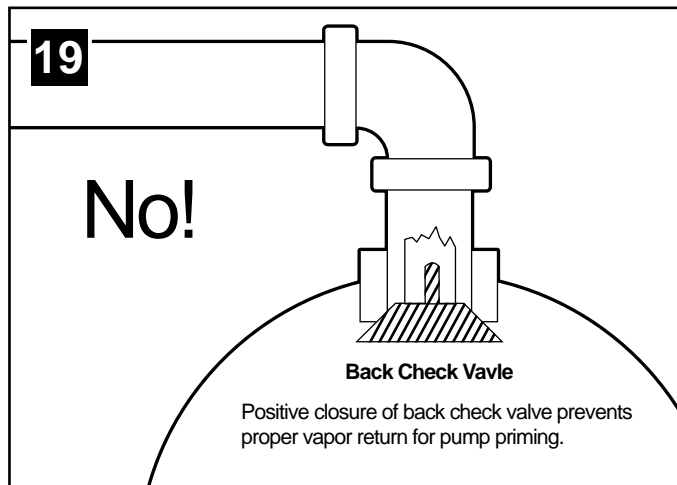

Where pumping from underground storage must be done, consult Engineer Data Page Z402.

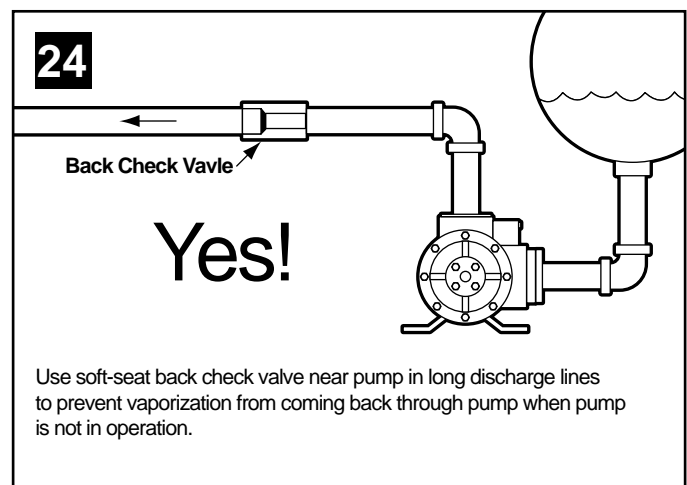
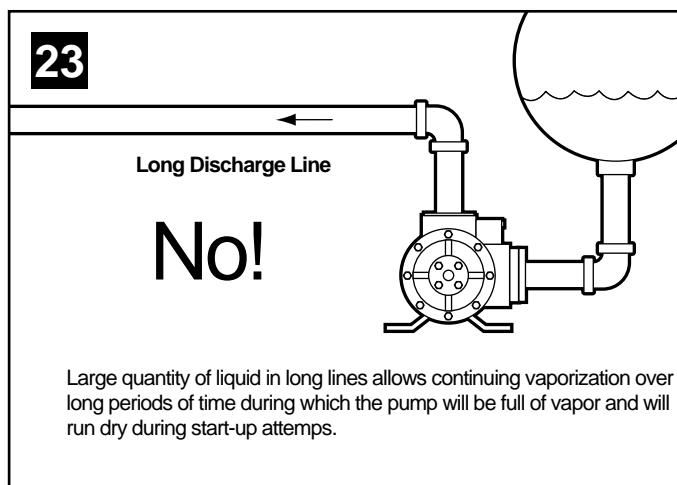

25

Good...

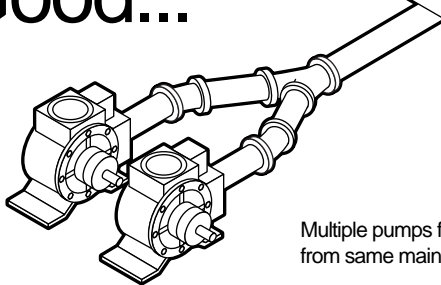

Multiple pumps fed from same main line.

26

OK...

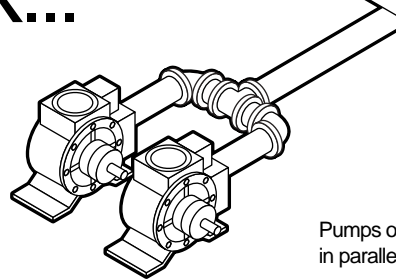

Pumps operating in parallel.

27

Best...

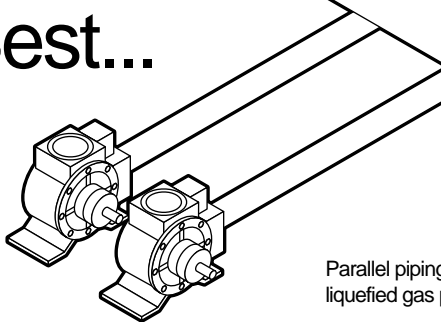

Parallel piping of liquefied gas pumps.

28

Bad...

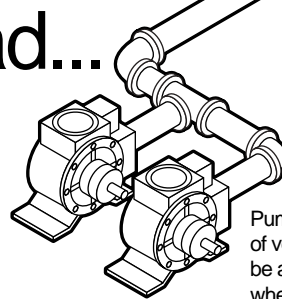

Pump No. 1 is starved because of venturi action at tee. This would be acceptable for installations where both pumps would never operate at the same time.

Inquire about Corken's Duplex-Series Pump Set.

29 No!

Don't pipe bypass line back into suction piping! Heat Buildup in recirculated products causes flashing of liquid to vapor with immediate cavitation and ultimate dry-running. This is why the bypass relief valves which are built into many positive displacement pumps should not be used for normal bypass action when handling liquefied gases. The internal valve should be considered to be a back-up safety relief in addition to a back-to-tank bypass valve and should be set to relieve at a pressure 10 to 20 psi higher than the working bypass. Some built-in bypass valves have the capability of being piped back-to-tank so check with the pump manufacturer.

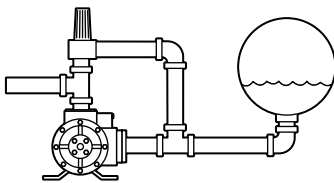

30

Yes!

Always pipe bypass back to tank! Make sure bypass line is large enough to handle full pump flow without excessive pressure build-up. Note that bypass line must be capable of bypassing full pump capacity without excessive pressure build-up. High pressure rise can cause bypass valve to chatter and vibrate.

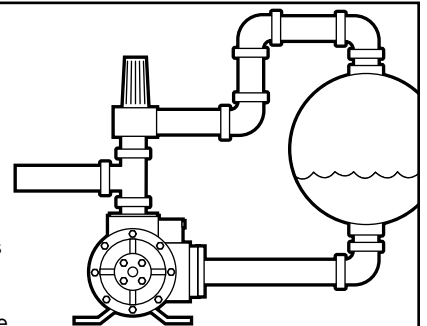

System Recommendations

PIPING

31 No!

To Vaporizer

Back check must be located to allow back-flow into tank from vaporizer.

32 No!

To Vaporizer

Back check must be located to allow back-flow into tank from vaporizer.

33 Better...

To Vaporizer

Back check valve protects pump but allows back flow through bypass valve into storage tank. Use back check without spring loaded valve to allow normal vapor elimination.

34 Best

Where A is a constant pressure bypass control valve and B is Corken B166 bypass and vapor elimination valve.

Valve A is a fixed pressure bypass like the Fisher 98H which limits the feed pressure into the vaporizer to a specific value regardless of system vapor pressure. A differential difference in pressure between the pump discharge and the tank. Differential valve B must be set to the maximum acceptable differential of the pump while fixed pressure valve A is set for the vaporizer pressure requirement.

35 Corken B166 Bypass Valve Functions.

Delivery line shut-off or pressure build up is so high that valve opens and relieves capacity back into supply tank.

No circulation - all pump capacity going to delivery.

Liquid from supply tank seeking its level in pump and bypass piping.

OUTLET INLET

FIG. 1 Relieving Operation OPEN

FIG. 2 Pumping Operation CLOSED

FIG. 3 Priming Operation OPEN

For pump capacities under 100 GPM, use a bypass valve with built-in vapor elimination where possible. Like Corken's B166 or T166 valves.

36

Some bypass valves, like the Corken B177, require tank pressure sensing lines. Check instructions for your valve.

Bypass Valve

THE CORKEN B166 VALVE

Your new CORKEN B166 Valve (Figure 1) is a patented, dual purpose automatic priming and differential bypass valve especially designed for high pressure volatile liquid service, but it is suitable also as a bypass valve for handling stable liquids. The B166 Valve was developed for use with the CORKEN Coro-Flo turbine regenerative pumps to keep the pump primed at all times and to act as a differential bypass when needed. The B166 is also ideal for centrifugal and other pumps.

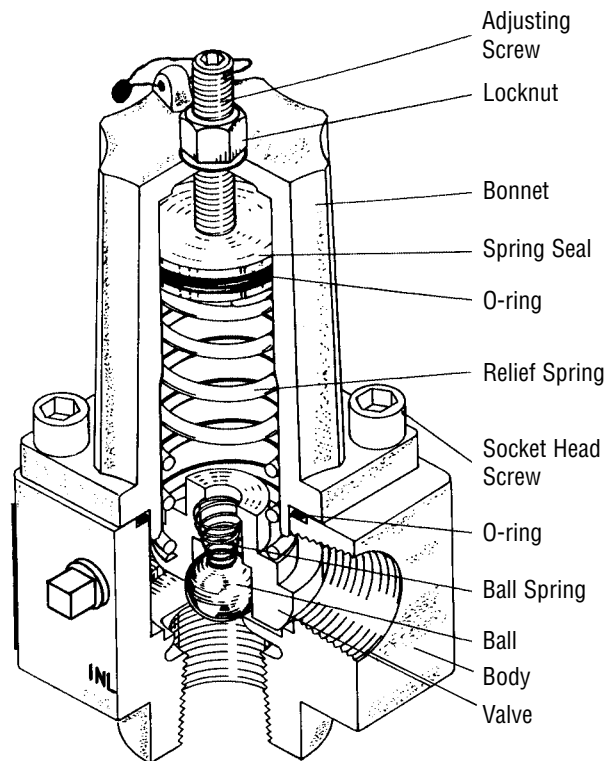

Figure 1

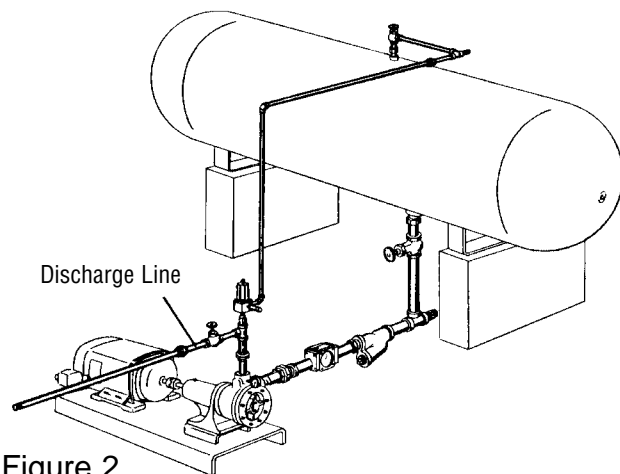

Figure 2

INSTALLATION OF B166 VALVE

Proper installation of the CORKEN B166 Valve will ensure optimum performance of the pump as well as the valve. Install your B166 Valve on the discharge side of the pump, either vertically or horizontally. All CORKEN Coro-Flo turbine pumps have a 3/4" NPT opening in the discharge nozzle for piping this valve. For other pumps a tee in the discharge line must be provided. The discharge piping from the valve must go to the vapor section of the supply tank into an excess flow valve, not a back check valve. The typical installation is shown in Figure 2. The recommended valve discharge pipe line sizes are given in the table below. For distances of 50 feet or more, the next larger pipe size should be used.

Recommended Valve Discharge Line Sizes

Flow Rate GPM	B166 Valve Size	
	3/4"	1"
Up to 20	3/4"	3/4"
Up to 40	1"	1"

ADJUSTMENT OF CORKEN B166 VALVE

The proper setting of the valve must be made at the time of installation. Start the pump and circulate liquid through the valve back to the tank. Turn the valve adjusting screw out (counterclockwise) to decrease the pressure and in (clockwise) to increase the pump discharge pressure.

Adjust the valve to open at the maximum pump pressure required to fill all containers.

Tighten the lock nut and permit the pump to circulate liquid through the valve. On stationary applications, if the motor overload protection device stops the motor, readjust the valve by turning the screw out another turn or two.

Once a satisfactory pressure adjustment has been made, attach the "tamper-proof" seal furnished with your valve to prevent unauthorized valve adjustment. On installations where the pump has an internal safety relief valve, the B166 bypass valve should be set at a pressure slightly lower than the pump internal safety relief valve.

NOTE:

On LP-gas installations, a maximum differential pressure of 125 psi is allowed by Underwriters' Laboratories, Inc. meeting the requirements of NFPA Pamphlet No. 58.

THE CORKEN T166 VALVE

Your new CORKEN T166 Valve (Figure 3) has been especially designed for use with delivery truck pumps to control the pump discharge pressure and to bypass excess liquid back to the truck tank. It is also quite satisfactory for service with any positive displacement pump within its capacity range and has been used in many stationary installations.

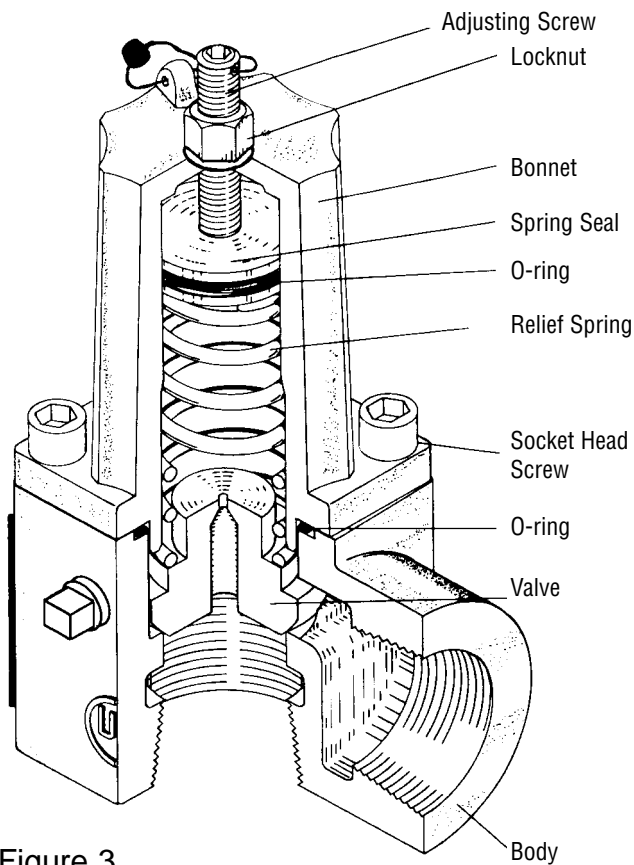

Figure 3

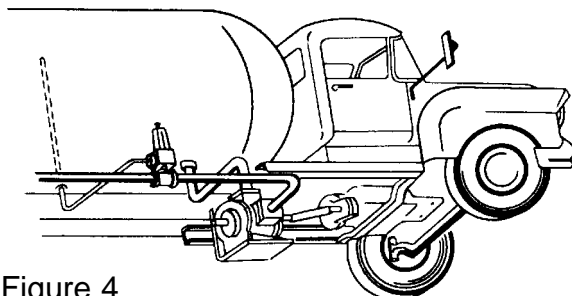

Figure 4

INSTALLATION OF T166 VALVE

Proper installation of the CORKEN T166 Valve will ensure optimum performance of the pump as well as the valve. Install your T166 Valve on the discharge side of the pump, either vertically or horizontally. The discharge piping from the valve should go to the vapor section of the truck tank into a filler type valve or a back check valve. A typical truck installation is shown in Figure 4. When the valve is being used for vapor venting on stationary applications using pumps with internal safety relief valves, the piping should be the same as that used for the CORKEN B166. The recommended valve discharge pipe line sizes are given in the table below. For distances of 50 feet or more, the next larger pipe size should be used.

Recommended Valve Discharge Line Sizes

Flow Rate GPM	T166 Valve Size	
	Up to 40	1-1/4"

ADJUSTMENT OF CORKEN T166 VALVE

The proper setting of the valve must be made at the time of installation. Start the pump and circulate liquid through the valve back to the tank. Turn the valve adjusting screw out (counterclockwise) to decrease the pressure and in (clockwise) to increase the pump discharge pressure.

Adjust the valve to open at the maximum pump pressure required to fill all containers. This is typically around 100 psi differential.

Tighten the lock nut and permit the pump to circulate liquid through the valve. On stationary applications, if the motor overload protection device stops the motor, readjust the valve by turning the screw out another turn or two.

Once a satisfactory pressure adjustment has been made, attach the "tamper-proof" seal furnished with your valve to prevent unauthorized valve adjustment. On installations where the pump has an internal safety relief valve, the T166 bypass valve should be set at a pressure slightly lower than the pump internal safety relief valve.

NOTE:

On LP-gas installations, a maximum differential pressure of 125 psi is allowed by Underwriters' Laboratories, Inc. meeting the requirements of NFPA Pamphlet No. 58.

Warranty Information

WARNING

Install, use and maintain this equipment according to CORKEN, INC. instructions and all applicable federal, state, local laws and codes, and NFPA Pamphlet 58 for LP-Gas or ANSI K61.1-1989 for Anhydrous Ammonia. Periodic inspection and maintenance is essential.
CORKEN ONE YEAR LIMITED WARRANTY

CORKEN, INC. warrants that its products will be free from defects in material and workmanship for a period of 12 months following date of purchase from CORKEN.

CORKEN products which fail within the warranty period due to defects in material or workmanship will be repaired or replaced, at CORKEN's option, when returned, freight prepaid, to CORKEN, INC., 3805 N.W. 36th Street, Oklahoma City, Oklahoma 73112.

Parts subject to wear or abuse, such as mechanical seals, blades, piston rings, and packing, and other parts showing signs of abuse are not covered by this limited warranty. Also, equipment, parts and accessories not manufactured by CORKEN but furnished with CORKEN products are not covered by this limited warranty and the purchaser must look to the original manufacturer's warranty, if any. This limited warranty is void if the CORKEN product has been altered or repaired without the consent of CORKEN.

All implied warranties, including any implied warranty of merchantability or fitness for a particular purpose, are expressly negated to the extent permitted by law and shall in no event extend beyond the expressed warranty period.

CORKEN DISCLAIMS ANY LIABILITY FOR CONSEQUENTIAL DAMAGES DUE TO BREACH OF ANY WRITTEN OR IMPLIED WARRANTY ON CORKEN PRODUCTS. Transfer of toxic, dangerous, flammable or explosive substances using CORKEN PRODUCTS is at the user's risk. Such substances should be handled by experienced, trained personnel in compliance with governmental and industrial safety standards.

WRITING THE FACTORY

For your convenience, the valve size and serial code are given on the valve nameplate. This serial code tells the month and year your valve was built. Space is provided below for you to keep a written record of this information. Always include the valve size and serial code when ordering parts.

Valve Model _____

Valve Size _____

Serial Code _____

Date Purchased _____

Date Installed _____

Purchased From _____

Installed By _____

ONE YEAR LIMITED WARRANTY

CORKEN, INC. warrants that its products will be free from defects in material and workmanship for a period of 12 months following date of purchase from CORKEN.

CORKEN products which fail within the warranty period due to defects in material or workmanship will be repaired or replaced at CORKEN's option, when returned, freight prepaid to CORKEN, INC., 3805 N.W. 36th St., Oklahoma City, Oklahoma 73112.

Parts subject to wear or abuse, such as mechanical seals, blades, piston rings, valves and packing, and other parts showing signs of abuse, neglect or failure to be properly maintained are not covered by this limited warranty. Also, equipment, parts and accessories not manufactured by CORKEN but furnished with CORKEN products are not covered by this limited warranty and the purchaser must look to the original manufacturer's warranty, if any. This limited warranty is void if the CORKEN product has been altered or repaired without the consent of CORKEN.

All implied warranties, including any implied warranty of merchantability or fitness for a particular purpose, are expressly negated to the extent permitted by law and shall in no event extend beyond the expressed warrantee period.

CORKEN DISCLAIMS ANY LIABILITY FOR CONSEQUENTIAL DAMAGES DUE TO BREACH OF ANY WRITTEN OR IMPLIED WARRANTY ON CORKEN PRODUCTS. Transfer of toxic, dangerous, flammable or explosive substances using CORKEN PRODUCTS is at the user's risk. Such substances should be handled by experienced, trained personnel in compliance with governmental and industrial safety standards

PRICES

All prices are f.o.b. factory at Oklahoma City U.S.A. Prices quoted are for acceptance within 30 days, but in the meantime may be changed upon proper notice. Prices of equipment for future delivery will be those in effect at time of shipment.

TERMS

Standard terms for all sales are net payment within thirty (30) days from the date of invoice unless it is the judgment of CORKEN that the financial condition of the purchaser warrants other terms. In the event the Purchaser fails to make payment in accordance with the conditions specified, the Purchaser shall pay interest on the amount due at the rate of 1.5% per month.

DESIGN

It is CORKEN's intention to continually improve the design and performance of its products as new ideas, new practices and new materials become available. Therefore, all published designs, specifications and prices are subject to minor modifications at the time of manufacture to coincide with this policy, without prior notice to the Purchaser. If the equipment purchased is to be used in an existing installation to match previously purchased equipment, material will be furnished to be interchangeable as near as may be feasible, but CORKEN reserves the right to substitute materials and designs.

SHIPMENTS

The prices shown include standard crating or packaging for normal rail or commercial truck shipments within the borders of the continental United States, Canada and Mexico. Consult Factory for Export Crating charges. All promises of shipment are estimates contingent upon strikes, fires, elements beyond our control or manufacturing difficulties, including the scheduled shipping dates of materials from our suppliers.

CANCELLATION CHARGES

There will be a minimum cancellation charge of 15% of the net price for any order which is canceled after having been accepted and officially acknowledged by CORKEN. In the event there is material involved that is manufactured by others, and is being purchased by CORKEN for the sole purpose of becoming part of this canceled order, the cancellation charges assessed CORKEN by these other manufacturers shall be borne by the Purchaser.

If shipment has already been made before notice of cancellation, the Purchaser will be charged all the freight costs involved in the handling of the order, including the charges necessary to get the equipment back to the respective warehouses of CORKEN and its suppliers, in addition to the cancellation charge described above.

RETURNED MATERIAL

Material may be returned to the factory ONLY if there is prior written authorization from CORKEN and accompanied by a Corken CSC number and the freight is paid by the shipper.

Material that is authorized for return will be inspected when received, and if it is of current design, unused, and in first-class resalable condition, credit will be allowed on the basis of the original invoice value less restocking charges. Returned material that is found to be worn, or in damaged condition, will not be accepted. The customer will be notified of this, and return shipping instructions, or permission to scrap such items will be requested. If no instructions are received within sixty (60) days after such notice, the material will be scrapped. Outside purchased materials and equipment may be returned for credit ONLY by CORKEN's prior written authorization, and must be in new and undamaged resalable condition, and of current design. Such returned materials are subject to a MINIMUM restocking charge of 25%.

LITERATURE

CORKEN will furnish, upon request and without charge to the Purchaser, six copies of paper prints of standard drawings, performance curves, and other current literature covering the pump or compressor and/or such other descriptive material that good judgment would consider necessary. Any additional material and/or special drawings will be charged for at appropriate rates determined by CORKEN. See Corken Optional Services in price pages for details.

FACTORY INSPECTION AND TESTS

Each article of CORKEN's manufacture passes a standard factory inspection and operating test prior to shipment. Special factory inspections, tests and/or certified test reports are all subject to a factory charge available upon request.

LIABILITY FROM USE OF PRODUCT

CORKEN has no control over the ultimate use of its products and specifically disclaims any liability damage, loss or fines which may arise from the use thereof. The user and purchaser shall hold CORKEN harmless from such damage, loss or fines. The user and purchaser shall determine the suitability of CORKEN products for the use intended and issue adequate safety instructions therefor.

Compliance with the Occupational Safety and Health Act and similar laws and regulations shall be the responsibility of the user of the product and not the responsibility of CORKEN.

Conversion Factors

English Measures - unless otherwise designated, are those used in the United States, and the units of weight and mass are avoirdupois units.

Gallon - designates to the U.S. gallon. To convert into the Imperial gallon, multiply the U.S. gallon by 0.83267. Likewise, the word ton designates a short ton, 2,000 pounds.

MULTIPLY	BY	TO OBTAIN
Bar	33.456	Feet H ₂ O @ 39°F
Bar	29.530	In. Hg @ 32°F
Bar	1.0197	kg/cm ²
Bar	14.504	Pounds/in ²
British Thermal Units	0.2520	Kilogram - calories
British Thermal Units	777.6	Foot - lbs.
British Thermal Units	3.927×10^4	Horsepower - hrs.
British Thermal Units	107.5	Kilogram - meters
British Thermal Units	2.928×10^4	Kilowatt - hrs.
Centimeters	0.3937	Inches
Centimeters	0.01	Meters
Centimeters	10	Millimeters
Centipoise	0.001	Pascal - second
Centipoise	0.01	Poises
Centistokes	0.01	Sq. cm / sec.
Centistokes	0.01	Stokes
Feet	30.48	Centimeters
Feet	0.166667	Fathoms
Feet	3.0480×10^{-4}	Kilometers
Feet	304.8	Millimeters
Feet	12	Inches
Feet	0.3048	Meters
Feet	1/3	Yards
Feet of water	0.0295	Atmospheres
Feet of water	0.8826	Inches of mercury
Feet of water	304.8	Kgs. / sq. meter
Feet of water	62.43	Lbs. / sq. ft.
Feet of water	0.4335	Lbs. / sq. inch
Gallons	3785	Cubic centimeters
Gallons	0.1337	Cubic feet
Gallons	231	Cubic inches
Gallons	3.785×10^{-3}	Cubic meters
Gallons	4.951×10^{-3}	Cubic yards
Gallons	3.785	Liters
Gallons	8	Pints (liq.)
Gallons	4	Quarts (liq.)
Gallons - Imperial	1.20095	U.S. gallons
Gallons - U.S.	0.83267	Imperial gallons
Gallons / min.	2.228×10^{-3}	Cubic feet / sec.

Solutions beyond products...

CORKEN[®]
IDEX

P.O. Box 12338, Oklahoma City, OK 73157
3805 N.W. 36th St., Oklahoma City, OK 73112
Phone (405) 946-5576 • Fax (405) 948-7343
E-mail corken@corken.com
Web address www.corken.com