

Installation, Operation & Maintenance Manual

PZ-Series Coro-Vane® Petroleum Pump For Refined Petroleum Products and Industrial Solvents

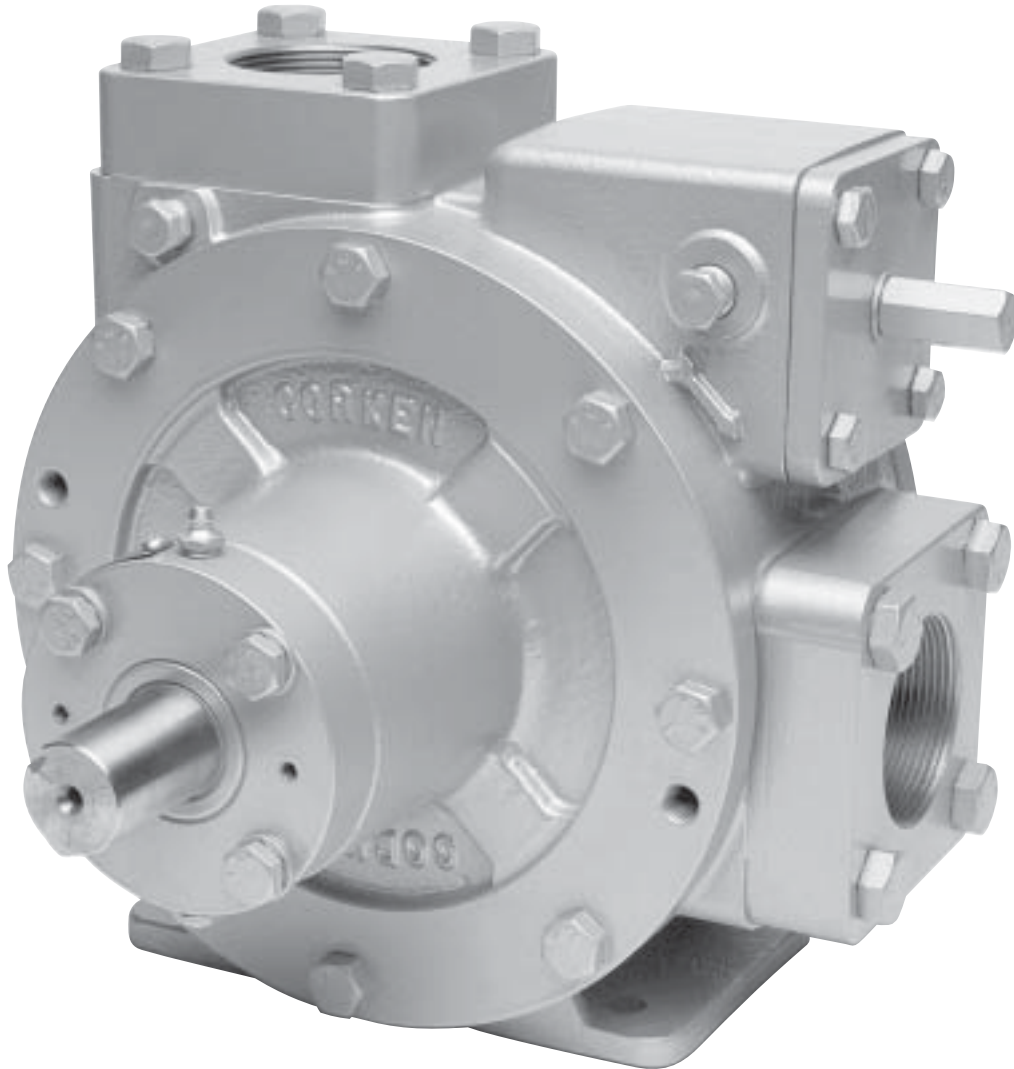

PZ7 Model with Standard Bypass Valve

Warning: (1) Periodic inspection and maintenance of Corken products is essential. (2) Inspection, maintenance and installation of Corken products must be made only by experienced, trained and qualified personnel. (3) Maintenance, use and installation of Corken products must comply with Corken instructions, applicable laws and safety standards (such as NFPA Pamphlet 58 for LP-Gas and ANSI K61.1-1972 for Anhydrous Ammonia). (4) Transfer of toxic, dangerous, flammable or explosive substances using Corken products is at user's risk and equipment should be operated only by qualified personnel according to applicable laws and safety standards.

Solutions beyond products...

 **CORKEN**[®]
IDEX

Warning

Install, use and maintain this equipment according to Corken's instructions and all applicable federal, state, local laws and codes. Periodic inspection and maintenance is essential.

Corken One Year Limited Warranty

Corken, Inc. warrants that its products will be free from defects in material and workmanship for a period of 12 months following date of purchase from Corken. Corken products which fail within the warranty period due to defects in material or workmanship will be repaired or replaced at Corken's option, when returned, freight prepaid to CORKEN, INC., 3805 N.W. 36th Street, Oklahoma City, Oklahoma 73112.

Parts subject to wear or abuse, such as mechanical seals, vanes, piston rings, packing and other parts showing signs of abuse are not covered by this limited warranty. Also, equipment, parts and accessories not manufactured by Corken but furnished with Corken products are not covered by this limited warranty and purchaser must look to the original manufacturer's warranty, if any. This limited warranty is void if the Corken product has been altered or repaired without the consent of Corken.

All implied warranties, including any implied warranty of merchantability or fitness for a particular purpose, are expressly negated to the extent permitted by law and shall in no event extend beyond the expressed warranty period.

Corken disclaims any liability for consequential damages due to breach of any written or implied warranty on Corken products. Transfer of toxic, dangerous, flammable or explosive substances using Corken products is at the user's risk. Such substances should be handled by experienced, trained personnel in compliance with governmental and industrial safety standards.

Contacting the Factory

Before you contact the factory, note the model number and serial number of your pump. The serial number directs us to a file containing all information on material specifications and test data applying to your specific pump. When ordering parts, the Corken service manual or IOM (Installation, Operations and Maintenance) manual should be consulted for the proper part numbers. ALWAYS INCLUDE THE MODEL NUMBER AND SERIAL NUMBER WHEN ORDERING PARTS.

The model and serial numbers are shown on the nameplate of the unit. Record this information for future reference.

Model no. _____

Serial no. _____

Date purchased _____

Date installed _____

Purchased from _____

Installed by _____

Table of Contents

Principles of the PZ-Series Pump	4
Exclusive Features of PZ-Series Pump	4
Installation of the PZ-Series Pump	4
Operation of the PZ-Series Truck Pump	5
Maintenance of Your Pump System	6
Pump Maintenance Schedule	6
Disassembly and Assembly Instructions for the PZ-Series Pump	6
Disassembly Instructions	6
Assembly Instructions	7
Mechanical Seal and Vane Replacement Instructions	8
Cleanliness and Workmanship	8
Lubrication	9
Repair Kits for the PZ-Series	10
Appendix A—Model Number and Identification Code	11
Appendix B—Technical Specifications	12
Appendix C—Performance Curves	13
Appendix D—Outline Dimensions for the PZ7	15
Appendix D—Outline Dimensions for the PZ10	16
Appendix D—Outline Dimensions for the Air Operated Valve (AOV) and Strainer	17
Appendix E—Parts Details for the PZ7 with the Standard Bypass Valve	18
Appendix E—Parts Details for the PZ10 with the Standard Bypass Valve	19
Appendix E—Parts Details for the PZ7 Air Operated Valve (AOV)	20
Appendix E—Parts Details for the PZ10 Air Operated Valve (AOV)	21
Appendix E—Parts Details for the Strainer	22
Appendix F—Trouble Shooting Guide for the PZ-Series Pump	23
Appendix G—Flush and Storage Instructions for the PZ-Series Pump	24

Principles of the PZ-Series Pump

The PZ-Series pump is a special type of rotary positive displacement pump, known as a sliding vane pump.

The sliding vane pump has many of the positive displacement advantages of the gear pump, plus the ability to compensate for wear, and operate at a lower noise level.

The sliding vane pump consists of a rotor turning in a cam machined eccentrically in relation to the rotor; thereby displacing the liquid trapped between the rotor, cam and vanes. The PZ-Series pumps are made with vanes produced from advanced polymers which exhibit extremely low coefficients of friction. The vanes are self-adjusting for wear which gives the pump long life.

Exclusive Features of the PZ-Series Pump

The pumping of volatile liquids is one of the most difficult of all pumping jobs, and pumping from a delivery truck makes it even more difficult, so more attention must be given to the design and manufacturing of the pump and to its installation and operation.

In addition to being especially suited for handling volatile liquids, your PZ-Series pump has a number of features to help make it more easily operated and maintained.

The CASE and HEADS are made of Ductile Iron, not Cast Iron, for extra strength and toughness.

The VANES are manufactured of advanced polymers to provide excellent life and quiet operation. After long service, the vanes are simply and inexpensively replaced.

SIDEPLATES may be reversed for extended service life. The sideplates are easily replaced should the need arise.

THE MECHANICAL SEAL is designed for longer life under greater loads and may be inspected or replaced without disturbing the piping of the pump. No special tools are needed.

BEARINGS are heavy-duty roller type for long bearing life.

THRUST BEARINGS are heavy-duty needle roller type rated for 4,000 lbs.

NONMETALLIC VANE DRIVERS do not penetrate the vanes like the conventional steel vane drivers.

Available with adjustable internal BYPASS VALVE or optional AIR OPERATED VALVE (AOV) for high and low flow control.

Installation of the PZ-Series Pump

The mechanical installation of the PZ-Series pump is a simple matter. A rotation arrow is located on the side of the pump so check the PTO to determine its direction of rotation. The PZ-Series pump will match either PTO rotation. Connect the drive shaft to the pump shaft that turns the pump in the direction of the arrow.

The PTO SELECTION is important. The pump requires a PTO with an average output speed of 500 to 700 RPM for maximum performance when the truck engine is operating at the proper speed to maintain oil pressure and water circulation.

THE DRIVESHAFT connecting the pump to the PTO should be of the "splined" or slip type. This type driveshaft permits the shaft to adjust for PTO movement and twisting of the truck frame. A fixed driveshaft transfers the forces directly into the pump and PTO and will shorten the life of both considerably. The yokes of the driveshaft universal joints must be positioned as shown on page 5, Figure 1. Improper positioning will soon wear them out and potentially destroy the bearings in the pump and PTO.

INLET PIPING should be as short as possible and at least the minimum diameter specified for the model with minimum restrictions so that the pressure drop is limited.

The outlet piping should include the following:

1. A pressure gauge should be installed in the pump outlet or near it. A pressure gauge is necessary to determine the efficiency of your pumping system.
2. If a meter with an air eliminator is installed, never pipe the eliminator directly into the pump inlet piping or into the liquid part of the system at any point (refer to the meter installation manual).
3. The discharge piping should be at least the same size as the meter piping.

Power Take-Off Drive Systems

Proper pump operation and long life is directly dependent upon a good drive system. Many truck pumps utilize a power train consisting of shafts and universal joints from a power take-off shaft on the truck engine to the pump.

There are several basic principles that should be followed in laying out a PTO drive. These principles should not be violated to produce a workable power train that results in long pump life and reduced drive wear.

First, the driver shaft and the driven shaft must be parallel to one another within plus or minus one degree. Improper alignment will cause jerking and back and forth "whip" to the pump shaft, thereby imparting a surging pulsation to the liquid flow, which results in noise, vibration and abnormal wear.

Second, the angle of the "floating" shaft should be within the limits for the particular equipment being used (usually a maximum of 15° at pump speeds up to 800 RPM). To ensure that shaft expansion or contraction does not distort the drive system, a splined slip joint should be placed between the two universal joints. The drive shaft should be of the "splined" or slip type to permit the shaft to adjust for PTO movement and twisting of the truck frame. A fixed drive shaft transmits the forces directly to the pump and PTO which will shorten the life of both considerably.

Third, the yokes of the drive shaft universal joints must be in a parallel position. Figure 1 on page 5 illustrates the proper arrangement of the yokes.

Improper installation of the U-joints will soon destroy them along with the bearings in the pump and PTO. Properly mounted, the second universal gives uniform motion to the drive shaft by compensating for the rotational error introduced by the first U-joint. An even number of universal joints (2, 4, 6 etc.) should always be used. An odd number of U-joints will cause unbalanced pump shaft rotation. This problem becomes greater with increased angularity.

Other points to consider include the proper sizing of the shaft components with a maximum horsepower load to be expected, good alignment of hanger bearings and proper pump coupling alignment.

Improper PTO systems account for a high percentage of truck pump failures. Always remember to disengage the clutch before shifting the PTO into gear. Shifting the PTO into gear without disengaging the clutch imparts an enormous shock on the PTO, drive shaft, pump and meter and will soon damage one or all of them.

For proper installation of pump drives, follow the rules listed below:

1. Driver shaft and pump shaft must be parallel, plus or minus one degree.
2. Operating angle of the "floating" shaft must be 15° maximum.
3. Universal yokes must be in line and parallel.
4. Splined slip joints must be used where needed.
5. Use an even number of universal joints.
6. Always use the least practical number of shafts.

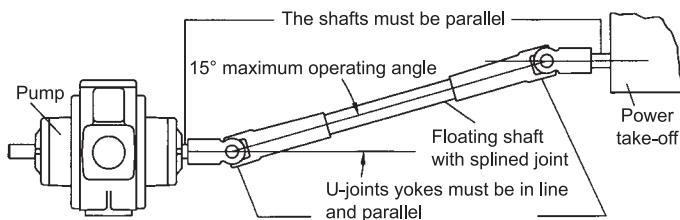

Figure 1, Shaft alignment

PTO selection and drive system design is extremely important. The PTO should have an average output speed up to 800 RPM to maximize the performance of the PZ-Series pump when the truck engine is operating at the recommended speed.

The designer of the drive system must select a PTO drive shaft capable of meeting the torque requirements of the pumping system.

Operation of the PZ-Series Pump Truck Pump

The following steps should be performed for the initial pumping operation:

1. Close the shutoff valve on the end of the delivery hose.
2. Start the pump and cycle the nozzle open and closed to clear all air from the system.

3. Check the discharge pressure on the outlet of the pump. This pressure is typically set at 80 to 95 psi.

4. Standard Bypass Valve

For a standard bypass valve, locate the adjustment set screw under the adjustment set screw cap (see parts details on pages 18 and 19). Turn adjustment screw clockwise to increase pressure and flow. Turn counter clockwise to decrease pressure and flow.

Close nozzle and check bypass pressure. If too high, turn adjustment screw counter clockwise until desired pressure is reached.

With the hose nozzle open, adjust the pump bypass valve setting to the desired flow rate. Close the nozzle slowly and check the system pressure. CAUTION: DO NOT EXCEED A CLOSED NOZZLE PRESSURE OF 125 PSI.

Replace adjustment set screw cap with seal washer and tighten.

5. Air Operated Valve (AOV) assembly

For pumps equipped with an Air Operated Valve (AOV) assembly, air must be supplied from the truck air system via a flow sensing valve. Approximately 70 psi (4.8 bar) minimum air pressure is required to properly operate the air operated valve. THE AIR PRESSURE MUST NOT EXCEED 125 psi (8.6 bar). The sensing valve should be installed in accordance with the diagram shown in Figure 2. This system depicts the additional use of a throttle control which is optional. All adjustments must be made at normal operating speeds.

- 5.1 Set the low pressure adjustment first by slowly closing the nozzle to relieve the air pressure in the AOV assembly.
- 5.2 Remove the adjustment stem cap and O-ring (see parts details on pages 20 and 21).

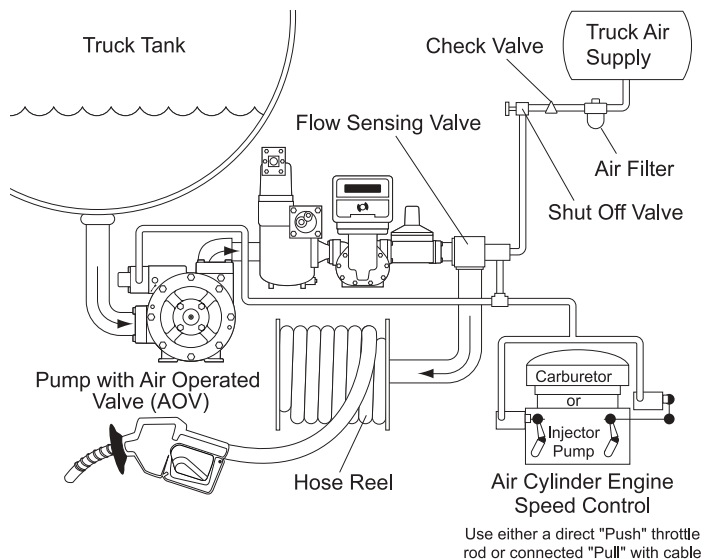

Figure 2, Typical truck delivery system using an AOV.

- 5.3 Turn the low pressure adjustment bushing counter-clockwise to decrease the bypass pressure and vice versa to increase the pressure (see parts details on pages 20 and 21).
 - 5.4 Re-install the O-ring and adjustment stem cap and tighten securely.
 - 5.5 Open and close the nozzle several times to ensure proper setting and repeatability.
 - 5.6 Slowly close the delivery nozzle again to relieve the air pressure in the AOV assembly.
 - 5.7 Remove the adjustment stem cap and O-ring.
 - 5.8 Adjust the locknuts clockwise to *decrease* delivery flow rate and/or pressure and vice versa to *increase* the flow rate. **NOTE: Make sure the locknuts are securely locked against each other before re-installing the adjustment stem cap and O-ring.**
 - 5.9 Slowly open the delivery nozzle and note delivery flow rate and/or pressure.
 - 5.10 Repeat steps 5.7 through 5.9 until desired flow rate and/or pressure are achieved.
6. You may increase the speed of the pump as long as it increases the flow through the delivery nozzle. It is recommended to turn the pump at approximately 575 RPM for optimum performance. However, the pump can be safely turned to 800 RPM if system conditions permit.

NOTE: IF PUMP SPEED IS INCREASED, BE CERTAIN THE METER AND PIPING SYSTEM WILL HANDLE THE INCREASED FLOW AND PRESSURE!

Maintenance of Your Pump System

Your PZ-Series pump requires regular maintenance and care like all mechanical equipment. A neglected or improperly repaired pump will result in premature failure and cause unsafe conditions. To promote product longevity and safety, maintenance must be performed by properly trained technicians. Make sure all safety systems are in place and the system pressure has been relieved before attempting ANY maintenance.

Pump Maintenance Schedule

Make sure the transfer hoses are not "kinked". A kinked hose can cause excessive pump discharge pressure. Always make sure your hoses are not out of date.

	Daily	Monthly	3 Months
Lubricate bearings		•	
Inspect drive coupling			•
Clean Inlet Strainer		•	
Check for leaks	•		
Inspect hose and fittings	•		

Bearing Lubrication

There are two lubrication points in which to grease the pump bearings; one zerk per bearing cap located at opposite ends of the pump. Four grease relief and seal ventilation fittings have been provided, two at each end of the pump, to help prevent over greasing the bearings. Over greasing can cause seal failure if grease passageways are blocked in some way. Remove relief fittings or confirm free movement of relief prior to greasing bearings. Clean each fitting before lubricating the bearings. This practice helps to prevent foreign material contamination of the bearings and accidental over-pressurization of the mechanical seals. Use only Ball Bearing Grease (MIL-G-10924C) with a temperature rating of -70°F.

Normal wear parts are the mechanical shaft seals, bearings, vanes, vane drivers and sideplates. All of these parts plus O-rings and grease seals are offered in the "repair kit." Use only genuine Corken replacement parts when repairing your PZ-Series pump. Follow the instructions provided with the parts.

When it becomes necessary to repair your pump or remove it from the system, you must be absolutely certain that all product being pumped is bled from the pump and connected piping. Once all the product has safely been bled from the pump and connected piping, make certain no pressure is left in the system. **SPECIAL CARE MUST BE TAKEN DURING THE BLEED DOWN PROCESS TO AVOID DANGER TO PERSONNEL AND PROPERTY IN THE AREA.** Take your time in bleeding your system and make proper provisions to vent or capture the product in accordance with local regulations. **ONLY A PROPERLY TRAINED INDIVIDUAL SHOULD BE ALLOWED TO BLEED A PUMPING SYSTEM.**

Disassembly and Assembly Instructions for the PZ-Series Pump

Disassembly Instructions

1. Truck engine must be turned off and PTO disengaged.
2. Bleed all product from the system as described above. **NOTE:** There is a 1/4" NPT connection in the bottom of the pump case that allows you to easily drain the pump.
3. Remove the PTO shaft or hydraulic drive motor, adapter, and coupling.
4. Remove the eight 7/16" head bolts from one head.
5. Slide head assembly off pump shaft ensuring the pump rotor-shaft remains in the pump.
6. Inspect the mechanical seal carbon face for scoring or pitting and discard if damaged. Ensure the rotor-shaft remains inside pump. **NOTE:** If rotor is pulled with head, it will disengage the seal assembly on the opposite side.
7. If the mechanical seal requires replacement, slide a screwdriver through the head assembly from the bearing cap and tap the stationary seal face out.

-
8. Remove the four 3/8" bolts from the bearing cap to gain access to the thrust bearing. Retain the bearing cap shims independently for each side of the pump. Inspect the thrust washers and needle roller assembly for scoring or pitting. Discard if damage found. Retain mounting ring for future use.
 9. Remove the spiral snap ring in the pump head to facilitate removal of the main bearing. Inspect the bearing rollers and inner race for scoring or pitting. Replace if damage is found. Retain the snap ring for future use. The main bearing can be easily removed by inserting a screwdriver through the head from the mechanical seal side and lightly tapping. Work the screwdriver around the inside perimeter of the bearing as the bearing is lightly pressed into the head.
 10. Inspect inner grease seal and head O-ring for cuts or abrasions and remove and change if necessary.
 11. Inspect the outer grease seal in the bearing cap for cuts or abrasions and remove if necessary.
 12. Repeat steps 3 through 10 for remaining head assembly.
 13. Using a bearing cap or flange bolt (3/8"), slide the sideplate off of the rotor-shaft while holding other end of rotor-shaft in place. Once removed, the rotor-shaft can be pulled slightly toward the remaining sideplate and allowed to rest within the pump case. Inspect the sideplates for wear. If sideplates are worn on both sides, discard for replacement.
 14. Carefully remove the rotor-shaft assembly with the vanes and drivers by cupping the lower vanes in place. Inspect vanes and drivers for wear or abrasions. Replace if damage is found.
 15. Inspect the rotor O.D. and cam inner surface for scoring or pitting. Should the condition arise, the pump should be completely replaced if severe scoring of the cam inner surface is discovered.
 16. If you have the standard bypass valve, remove the bypass valve adjustment screw cap and turn the adjustment screw counterclockwise to relieve the spring tension. Remove the four 3/8" bolts from the bypass valve cap. **Use caution as a small amount of spring tension will remain on the bypass valve spring before complete bolt removal.** Inspect bypass valve, spring, and bypass valve cap O-ring for wear, abrasions, etc. Replace if damage is found.
 17. If you have an Air Operated Valve (AOV), ensure the air supply pressure has been relieved and the supply line disconnected from the valve housing. Remove the outer cap and discard the O-ring from underneath. Remove the retainer ring and locknuts from the adjustment stem. Remove the four 3/8" bolts and lock washers from the bypass valve housing. **Use caution as a small amount of spring tension may remain on the bypass valve spring.** Carefully remove the AOV assembly from the pump along with the spring and valve.

Remove and discard the gasket and clean the gasket areas. Remove the two recessed-head machine screws and the diaphragm cover plate. Slide the diaphragm assembly out from the housing. Remove the vent plate from between the two diaphragms. Inspect the diaphragms, spring, and valve for abrasions and replace if necessary.

Assembly Instructions

1. Place three vanes into the upper three rotor-shaft slots. Ensure the curved tip of each blade faces radially outward and all in the same direction of rotation.
2. While cupping these vanes in place, rotate the rotor-shaft over 180° and install the three blade drivers.
3. Place rotor-shaft and blade assembly into pump case with the three vanes on the bottom. Ensure the ribs in the vanes face into the direction of rotation of the pump (see parts details on pages 18 and 19).
4. Place the remaining three vanes into the upper rotor-shaft slots facing the same direction as the first three vanes.
5. Install both sideplates into the pump simultaneously to keep the rotor-shaft level and centered in the pump case. Rotate each sideplate until the square notch is in the twelve o'clock position. Rotate the rotor-shaft to expose the seal drive pins.
6. Install the mechanical seal assemblies onto each end of the rotor-shaft. Ensure the seal drive pin properly engages the mechanical seal retainer detent. Lightly oil each carbon seal face.
7. Press the inner grease seals into each head with the cup opening toward the mechanical seal.
8. Press the main bearings into each head and install the spiral retainer ring.
9. Install the stationary seal face by applying a light oil—DO NOT use WATER based penetrants—and pressing into place with the protective cardboard disc and your fingers. Apply another coat of light oil to the face to remove any debris from installation.
10. Install the head O-ring and lubricate with light oil.
11. Carefully slide the first head assembly over the rotor-shaft ensuring the rotor-shaft remains within the pump case. Install the eight 5/8" hex head bolts and torque in a crossing pattern to 45 ft•lb. Repeat for remaining head assembly.
12. Install thrust bearing assemblies onto each mounting ring and place over each end of the rotor-shaft. Ensure the needle roller assemblies are sandwiched between the thrust washers and their orientation is facing outward from the pump.
13. Press each outer grease seal into each bearing cap.

14. Place one bearing cap over the end of the rotor-shaft and bolt in place finger tight. Grasp the rotor-shaft and ensure it does not turn by hand. Measure the gap between the head and bearing cap. Remove the bearing cap and install the measured amount of shims plus .006" (yellow shims are .020", brown shims are .010", and red shims are .002"). Round up if necessary. Install bearing cap with four 3/8" x 1 1/2" bolts and lock washers and torque to 25 ft•lb.

15. Place the remaining bearing cap over the other end and again tighten the four bolts finger tight. Again, measure the gap between the head and the bearing cap and remove the bearing cap. Install the measured amount of shims plus .002" and install bearing cap as described above.

16. Ensure the pump rotates smoothly without binding. If binding occurs repeat steps 14 and 15.

17. If you have a standard bypass valve, install the O-ring into the O-ring groove in the bypass valve cap and lubricate using light oil. Install the valve, spring, guide, and cap on the pump with the four 3/8" bolts and torque to 15 ft•lbs.

18. If you have an Air Operated Valve (AOV) assembly, install the vent plate between the two diaphragms ensuring proper orientation with the screw holes in the housing. Slide the diaphragm assembly into the housing and install the diaphragm cover plate and recessed-head machine screws and tighten securely. Install this assembly with the valve, spring, and gasket to the pump using the four 3/8" bolts and lock washers and torque to 15 ft•lbs. Install both locknuts all the way down the adjustment stem and replace the retainer ring. Install the new O-ring and outer adjustment stem cap. Refer to *Operation of the PZ Series Truck Pump* on page 5 for adjustment procedure.

19. Grease bearings per the instructions listed on page 6 under Pump Maintenance Schedule.

20. Install the pump according to the installation guidelines mentioned previously on page 4.

2. Remove the PTO shaft or hydraulic drive motor, adapter, and coupling.
3. Remove the eight 5/8" hex head bolts from one head.

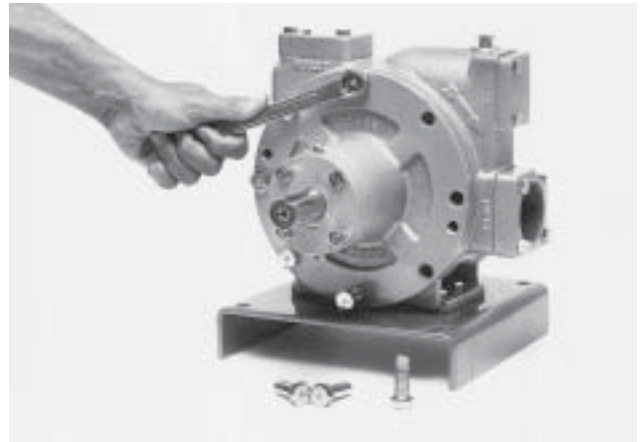

4. Slide one head assembly off the pump shaft ensuring the pump rotor-shaft remains in the pump.
5. Remove the mechanical seal carbon face assembly while pressing against the sideplate ensuring the rotor-shaft remains within the pump case.

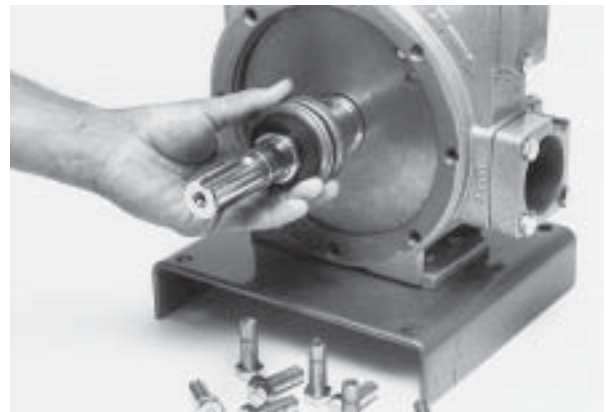

6. Remove the inner grease seal and stationary face by inserting a screwdriver through the head assembly from the bearing cap and tapping the grease seal and stationary face out.

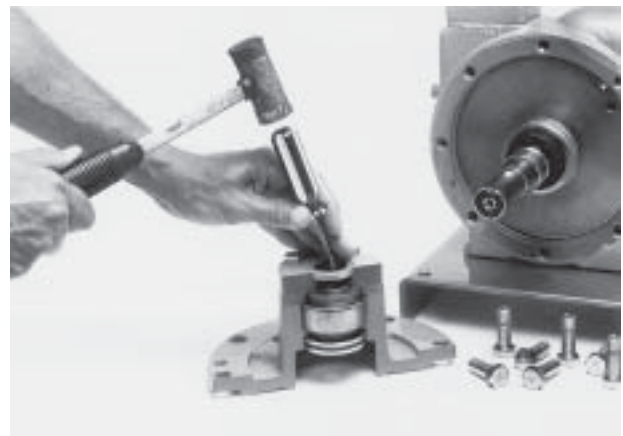

Mechanical Seal and Vane Replacement Instructions

Cleanliness and Workmanship

Even the smallest amount of dirt on your new seal can cause early failure. Keep all parts, tools and your hands clean while installing the seal. Never touch the smooth lapped faces of the carbon rotor or seal seat.

Lastly, your Corken pump is a precision piece of equipment with very close clearances. Treat it as such. Never use force during assembly or disassembly.

1. CAUTION: Bleed all pressure and product from the pump and piping before installing your new seal assembly.

7. Using the old seal stationary face, press a new inner grease seal in place ensuring the seal cup faces toward the mechanical seal. This can be accomplished with a hammer and drift.
8. Apply a light oil to the new stationary seal face O-ring and press in with your fingers ensuring the grooved side faces the main bearing.



9. Repeat steps 3 through 8 for the remaining head assembly.
If vane replacement is necessary follow steps 10 through 16. If not proceed to step 17.

10. Using a bearing cap or flange bolt (3/8"), slide one sideplate off of the rotor-shaft while holding other end of rotor-shaft in place. Once removed, the rotor-shaft can be pulled slightly toward the remaining sideplate and allowed to rest within the pump case. Inspect the sideplates for wear. If sideplates are worn on both sides, discard for replacement.

11. Remove the rotor-shaft assembly from the pump case by cupping the bottom three vanes with your hand. This will not allow the vanes and drivers to fall from the rotor-shaft slots.

12. Place three vanes into the upper three rotor-shaft slots. Ensure the curved tip of each vane faces radially outward.

13. While cupping these vanes in place, rotate the rotor-shaft over 180° and install the vane drivers.

14. Place rotor-shaft and blade assembly into pump case with the three vanes on the bottom. Ensure the ribs in the vanes face into the direction of rotation of the pump.

15. Place the remaining three vanes into the upper rotor-shaft slots facing the same direction as the first three vanes.

16. Install both sideplates into the pump simultaneously to keep the rotor-shaft level and centered in the pump case. Rotate each sideplate until the square notch is in the twelve o'clock position. Rotate the rotor-shaft to expose the seal drive pins.

17. Install the mechanical seal assemblies onto each end of the rotor-shaft. Ensure the seal drive pin properly engages the mechanical seal retainer detent. Lightly oil each carbon seal face.

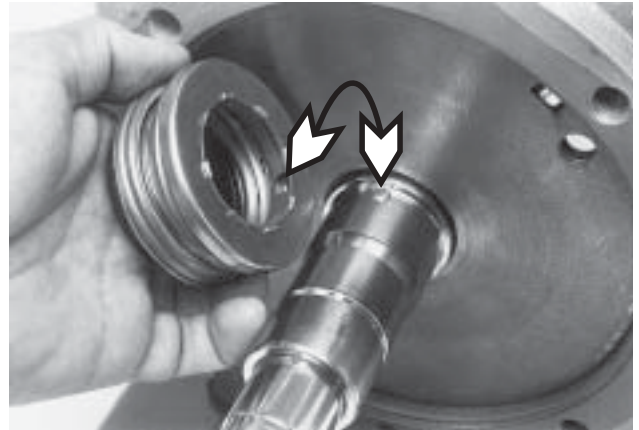

18. Lubricate the head O-ring and roll into place on the head.

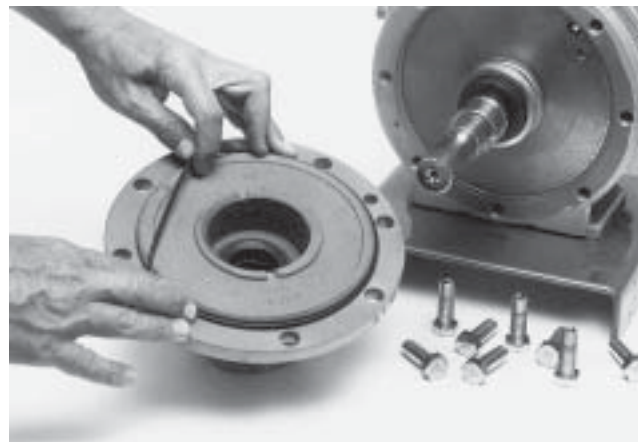

19. Install each head by supporting the back end of the rotor-shaft and working the head into place over the rotor-shaft.

20. Install the head bolts and torque to 45 ft•lb.

21. Grease bearings per instructions listed on page 6 under Pump Maintenance Schedule and the instructions listed below.

Lubrication

Regrease the bearing after thoroughly cleaning the grease opening and fittings. If dirt is forced into the bearings, early failure will result.

Special relief fittings have been provided to help prevent over-greasing the bearings. Excessive grease may drip out after lubrication. Over-greasing can damage the pump bearings and cause seal leaks.

Use only recommended ball bearing grease. If you use a hand grease gun, put the grease in slowly and stop as soon as the relief fitting opens.

Grease the U-joints and the spline of the drive shaft when greasing the pump.

Repair Kits for the PZ-Series

PZ7 Repair Kit 5497-X1A (Buna-N)

Part Number	Description	Qty.
1480	Gasket	1
2-142A	O-ring, Buna-N	1
2-234A	O-ring, Buna-N	2
2270	Shaft key	1
2754-X	Roller bearing	2
4262-X	Vane driver	3
4431-XA2	Seal assembly, Buna-N	2
4432	Thrust bearing	2
4435	Thrust bearing mounting ring	2
4439	Bearing cap shim (0.002")	8
4439-1	Bearing cap shim (0.010")	2
4439-2	Bearing cap shim (0.020")	2
4441	Grease seal	2
5372	Vane	6

PZ7 Repair Kit 5497-X1D (Viton®¹)

Part Number	Description	Qty.
1480	Gasket	1
2-142D	O-ring, Viton® ¹	1
2-234D	O-ring, Viton® ¹	2
2270	Shaft key	1
2754-X	Roller bearing	2
4262-X	Vane driver	3
4431-XD2	Seal assembly, Viton® ¹	2
4432	Thrust bearing	2
4435	Thrust bearing mounting ring	2
4439	Bearing cap shim (0.002")	8
4439-1	Bearing cap shim (0.010")	2
4439-2	Bearing cap shim (0.020")	2
4441	Grease seal	2
5372	Vane	6

PZ10 Repair Kit 5498-X1A (Buna-N)

Part Number	Description	Qty.
1480	Gasket	1
2-234A	O-ring, Buna-N	3
2270	Shaft key	1
2754-X	Roller bearing	2
4262-X	Vane driver	5
4431-XA2	Seal assembly, Buna-N	2
4432	Thrust bearing	2
4435	Thrust bearing mounting ring	2
4439	Bearing cap shim (0.002")	8
4439-1	Bearing cap shim (0.010")	2
4439-2	Bearing cap shim (0.020")	2
4441	Grease seal	2
5365	Vane	6

PZ10 Repair Kit 5498-X1D (Viton®¹)

Part Number	Description	Qty.
1480	Gasket	1
2-234D	O-ring, Viton® ¹	3
2270	Shaft key	1
2754-X	Roller bearing	2
4262-X	Vane driver	5
4431-XD2	Seal assembly, Viton® ¹	2
4432	Thrust bearing	2
4435	Thrust bearing mounting ring	2
4439	Bearing cap shim (0.002")	8
4439-1	Bearing cap shim (0.010")	2
4439-2	Bearing cap shim (0.020")	2
4441	Grease seal	2
5365	Vane	6

¹Viton® is a registered trademark of the Dupont company.

Appendix A—Model Number and Identification Code for PZ-Series

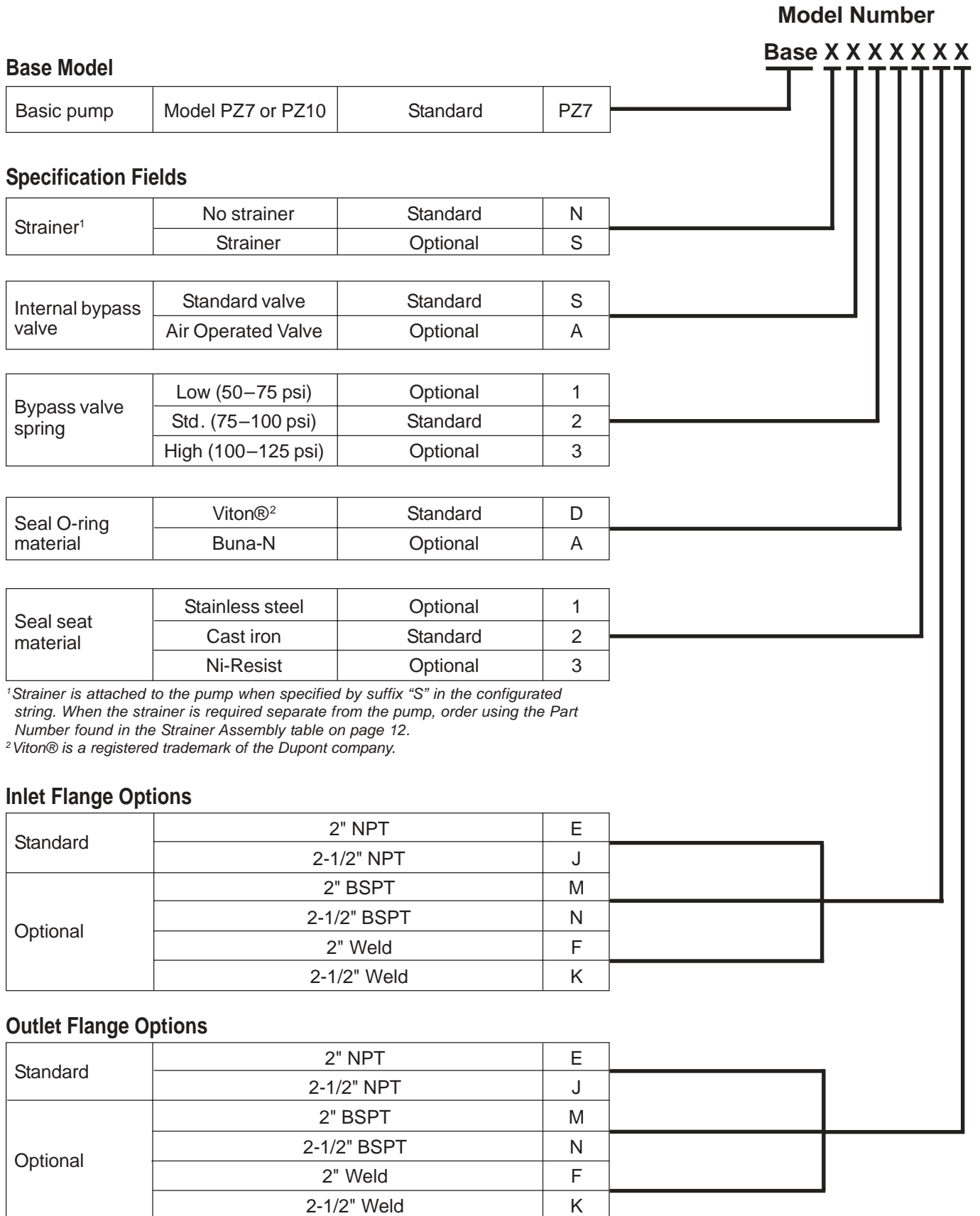

Appendix A—Model Number and Identification Code for Strainer and Air Operated Valve (AOV)

Strainer Assembly¹

Strainer assembly	Seal Material	Strainer Assy. Part Number
	Viton® ² (standard)	5422-XD
	Buna-N (optional)	5422-XA

¹Strainer Assembly ordered by Part Number when not assembled to the pump.

²Viton® is a registered trademark of the Dupont company.

Air Operated Valve Assembly (AOV)

Air Operated Valve (AOV)	For Pump Models	AOV Part Number
	PZ7	5470-X
	PZ10	5462-X

Appendix B—Technical Specifications for PZ7 and PZ10

Operating Specifications

Standard connections:	2" or 2-1/2" NPT
Optional connections:	2" or 2-1/2" Slip-on weld, BSPT
Maximum differential pressure:	125 psid (8.6 bar)
Operating temperature range:	Up to 300°F (149°C)
Maximum working pressure:	200 psi (13.8 bar)
Maximum speed:	800 RPM
Fluids:	For refined petroleum products and industrial solvents

Material Specifications

Part	Model	Material
Case	All	Ductile iron ASTM A536
Head	All	Ductile iron ASTM A536
Flanges	All	Ductile iron ASTM A536
Rotor	All	Ductile iron ASTM A536
Bearing cap	All	Ductile iron ASTM A536
Sideplates	All	Cast iron Class 30
Vanes & vane drivers	All	Advanced polymer
By-pass valve	All	17-4 PH Stainless steel
By-pass spring	All	Steel
Seal seat	All	Cast iron (standard), Stainless steel and Ni-Resist (optional)
Seal metal parts	All	Steel
Shaft	All	8620 steel
Thrust bearing	All	Steel
O-rings	All	Viton® ¹ (standard), Buna-N (optional)

¹Viton® is a registered trademark of the Dupont Company

Appendix C—Performance Curves¹

PZ7 Truck Pump

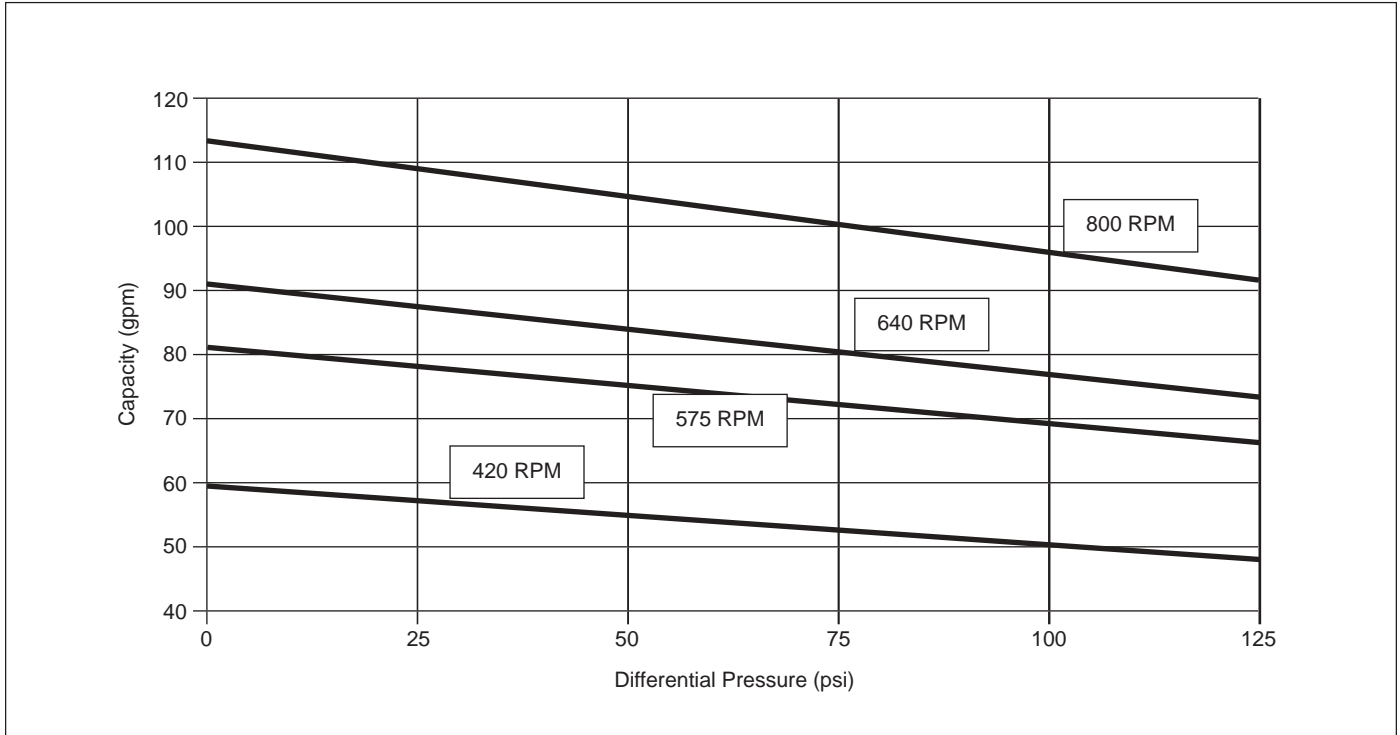

Pump Speed RPM	Differential Pressure		Nominal Flowrate		Brake HP Required		Torque Required	
	psi	bar	gpm	L/min	bhp	kW	in•lbs	N•m
800	90	6.2	98	371	6.8	5.0	536	60.5
800	50	3.4	105	397	3.8	2.2	299	33.8
640	90	6.2	78	295	5.5	4.1	542	61.2
640	50	3.4	84	318	3.1	2.3	305	34.5
575	90	6.2	70	273	4.9	3.7	537	60.7
575	50	3.4	75	284	2.7	2.0	296	33.4
420	90	6.2	51	182	3.6	2.7	540	61.0
420	50	3.4	55	197	2.0	1.5	300	33.9

¹These curves depict performance of the PUMP ONLY. Performance will vary in applications due to system design and variables. Approximate capacities and horsepowers are based on 38 SSU (3 cP) fluid.

Appendix C—Performance Curves¹

PZ10 Truck Pump

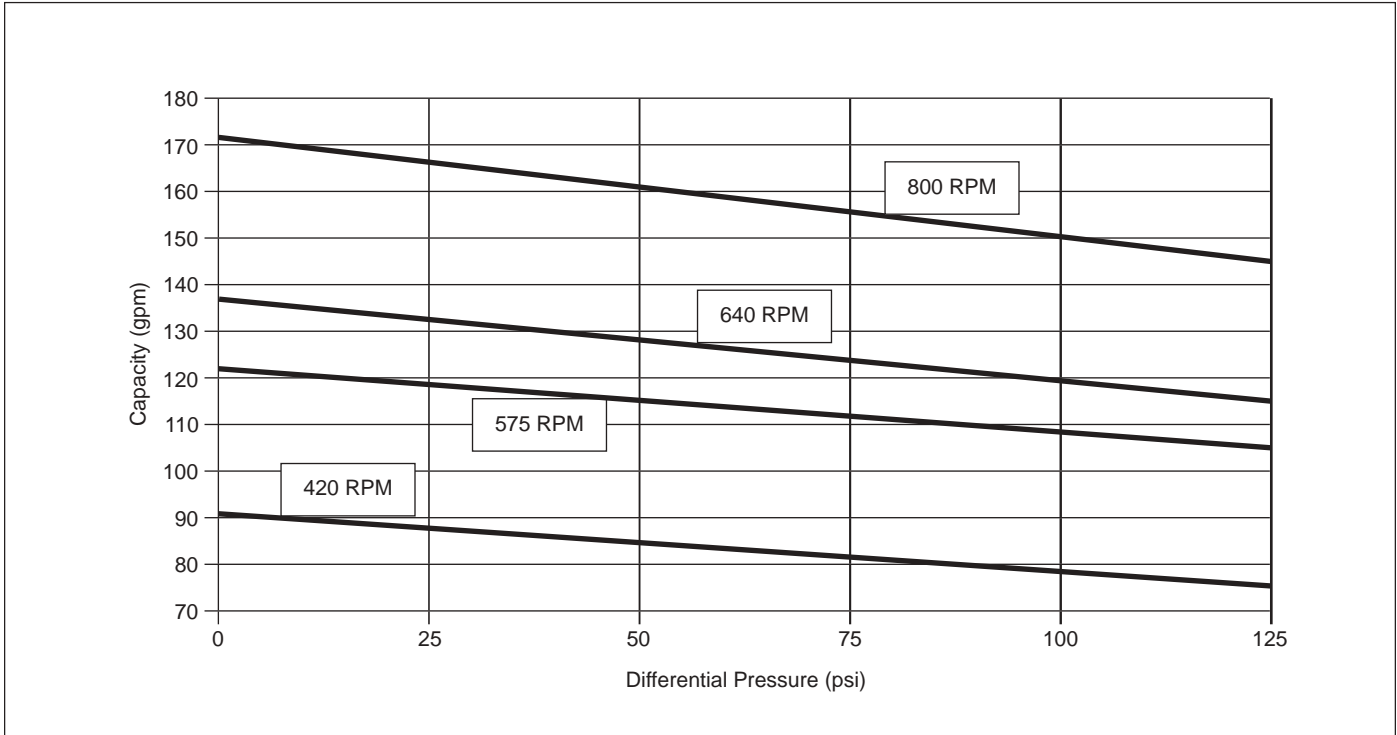

Pump Speed	Differential Pressure		Nominal Flowrate		Brake HP Required		Torque Required		
	RPM	psi	bar	gpm	L/min	bhp	kW	in•lbs	N•m
800	800	90	6.2	152	575	10.3	7.7	811	91.7
800	800	50	3.4	161	609	5.7	4.3	449	50.7
640	640	90	6.2	121	458	8.2	6.1	808	91.2
640	640	50	3.4	128	485	4.6	3.4	453	51.2
575	575	90	6.2	109	413	7.3	5.4	800	90.4
575	575	50	3.4	115	435	4.1	3.1	449	50.8
420	420	90	6.2	80	303	5.4	4.0	810	91.6
420	420	50	3.4	85	321	3.0	2.2	450	50.9

¹These curves depict performance of the PUMP ONLY. Performance will vary in applications due to system design and variables. Approximate capacities and horsepowers are based on 38 SSU (3 cP) fluid.

Appendix D—Outline Dimensions for the PZ10

PZ10 with Standard Bypass Valve

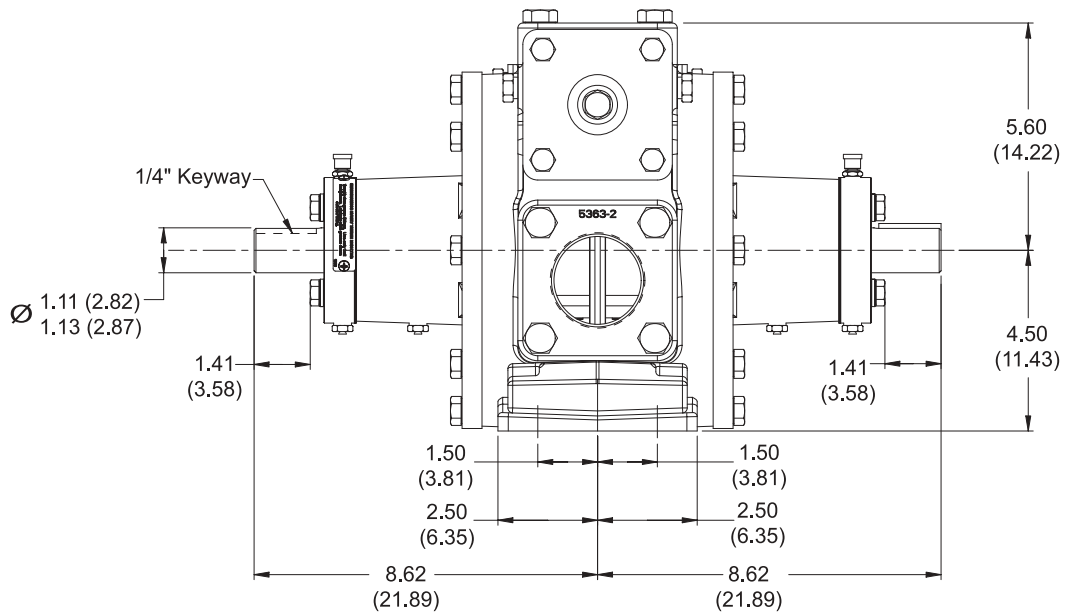

Inches (centimeters)

PZ10 with Standard Bypass Valve

PZ10 with Air Operated Valve (AOV)

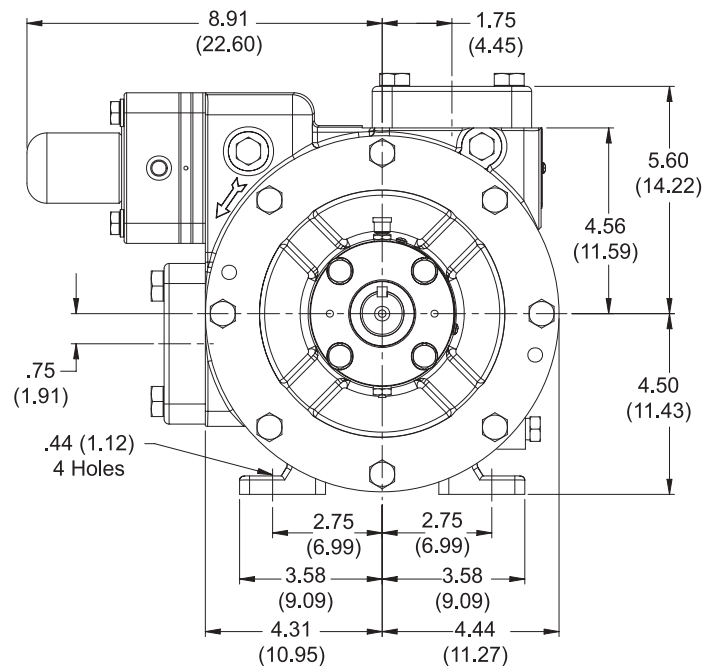
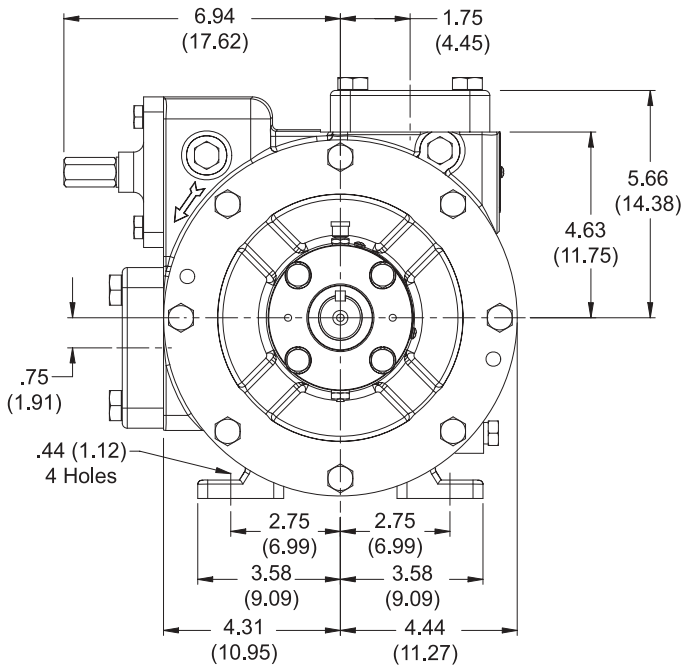

Inches (centimeters)

Appendix D—Outline Dimensions for Air Operated Valve and Strainer

5470-X Air Operated Valve (AOV) for PZ7 Pump

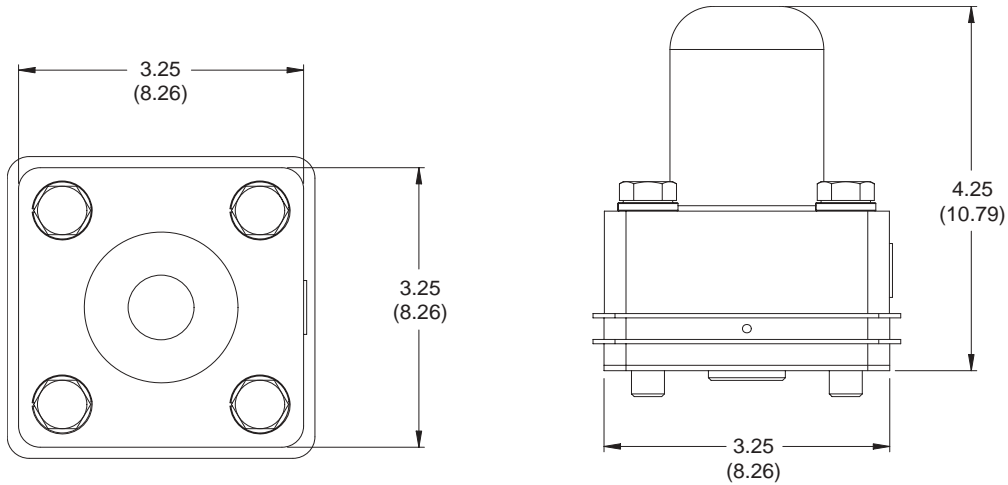

Inches (centimeters)

5462-X Air Operated Valve (AOV) for the PZ10 Pump

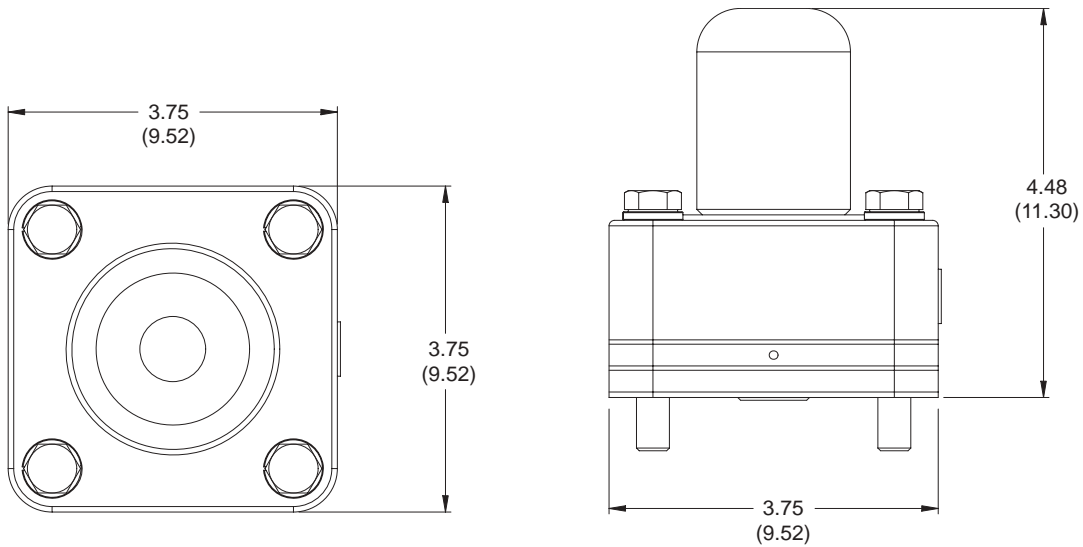

Inches (centimeters)

5422-X Strainer Assembly for the PZ7 and PZ10 Pump

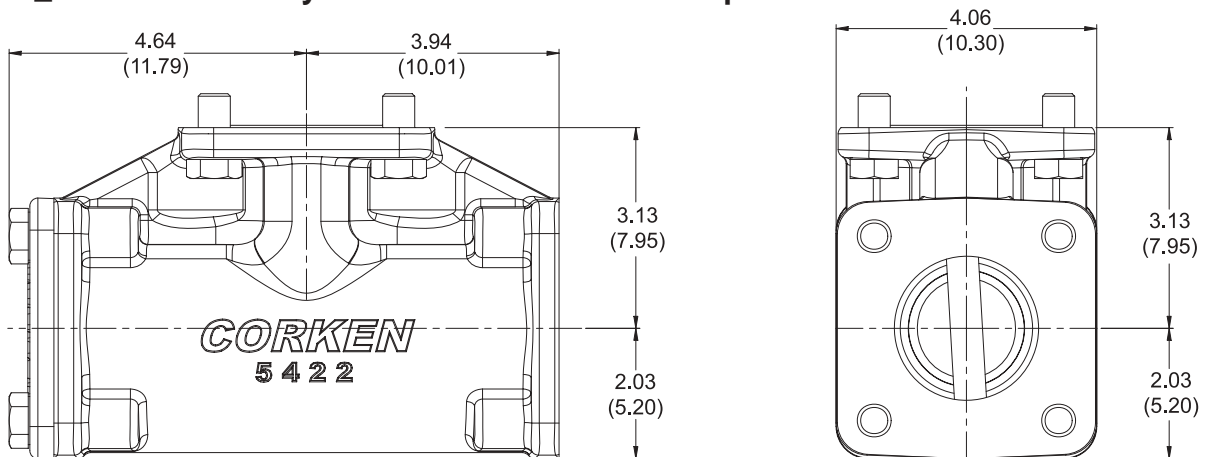

Inches (centimeters)

Appendix E—Part Details for the PZ7 with Standard Bypass Valve

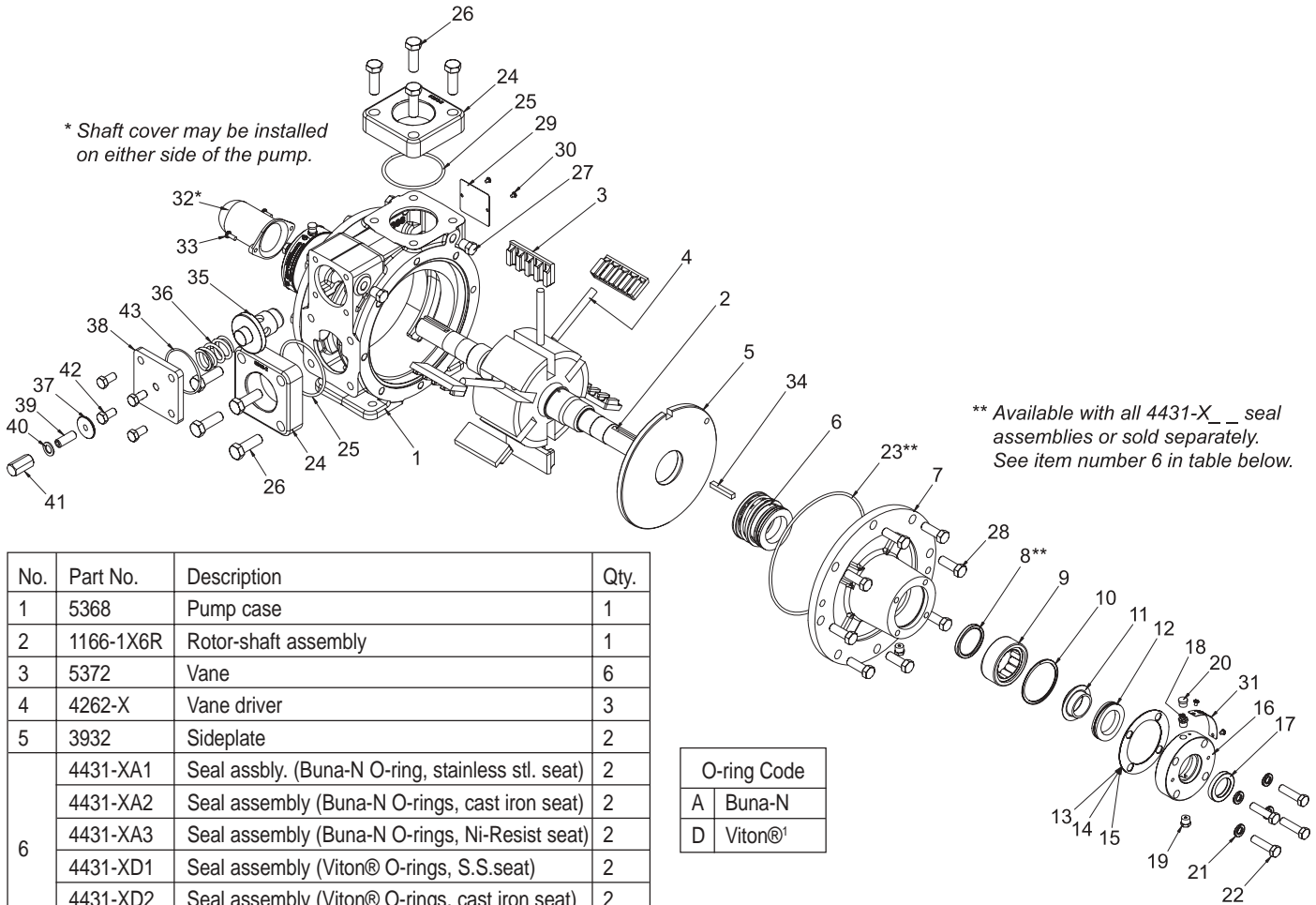

No.	Part No.	Description	Qty.
1	5368	Pump case	1
2	1166-1X6R	Rotor-shaft assembly	1
3	5372	Vane	6
4	4262-X	Vane driver	3
5	3932	Sideplate	2
6	4431-XA1	Seal assbly. (Buna-N O-ring, stainless stl. seat)	2
	4431-XA2	Seal assembly (Buna-N O-rings, cast iron seat)	2
	4431-XA3	Seal assembly (Buna-N O-rings, Ni-Resist seat)	2
	4431-XD1	Seal assembly (Viton® O-rings, S.S.seat)	2
	4431-XD2	Seal assembly (Viton® O-rings, cast iron seat)	2
	4431-XD3	Seal assembly (Viton® O-rings, Ni-Resist seat)	2
7	4416	Head	2
8	4438 ²	Grease seal/oil seal	2
9	2754-X	Roller bearing	2
10	2760-244	Retainer ring	2
11	4435	Thrust bearing mounting ring	2
12	4432	Thrust bearing assembly	2
13	4439-2	Bearing cap shim (0.020")	2
14	4439-1	Bearing cap shim (0.010")	2
15	4439	Bearing cap shim (0.002")	8
16	4417	Bearing cap	2
17	4441	Grease seal	2
18	2158	Grease zerk	2
19	1343	Grease relief fitting	4
20	2159	Lubricap	2
21	7206-037A	Lock washer (3/8")	8
22	7001-037NC150A	Hex head bolt	8
23	2-260_ ^{2,3}	O-ring	2
24	5363-2	Flange (2" NPT)	2
	5363-2.5	Flange (2-1/2" NPT)	2
	5367-2	Flange (2" BSPT)	2
	5367-2.5	Flange (2-1/2" BSPT)	2
	5363-2S	Flange (2" Weld)	2
	5363-2.5S	Flange (2-1/2" Weld)	2

No.	Part Number	Description	Qty.
25	2-234_ ³	O-ring	2
26	7001-050NC175A	Hex head bolt	8
27	3442	Pipe plug (1/4" NPT)	5
28	7001-043NC125A	Hex head bolt	16
29	2397	Name plate	1
30	7012-006SF019E	Pan head Phillip (6-32 x 3/16")	6
31	1359	Lubrication plate	2
32*	4985	Shaft cover	1
33	7012-010SF050E	Pan head Phillip (10-24 x 1/2")	2
34	2270	Shaft key	1
35	5454	Bypass valve	1
36	5477	Bypass valve spring (50–75 psi)	1
	5407	Bypass valve spring (75–100 psi)	1
	5480	Bypass valve spring (100–125 psi)	1
37	5447	Bypass valve spring guide	1
38	5446	Bypass valve cap	1
39	7006-043NC125A	Adjustment set screw	1
40	1480	Gasket	1
41	2458	Adjustment set screw cap	1
42	7001-037NC075A	Hex head bolt	4
43	2-142_ ³	O-ring	1

¹ Registered trademark of the DuPont company.

² Available with all 4431-X__ seal assemblies or sold separately.

³ _ denotes O-ring code listed above.

Appendix E—Part Details for the PZ10 with Standard Bypass Valve

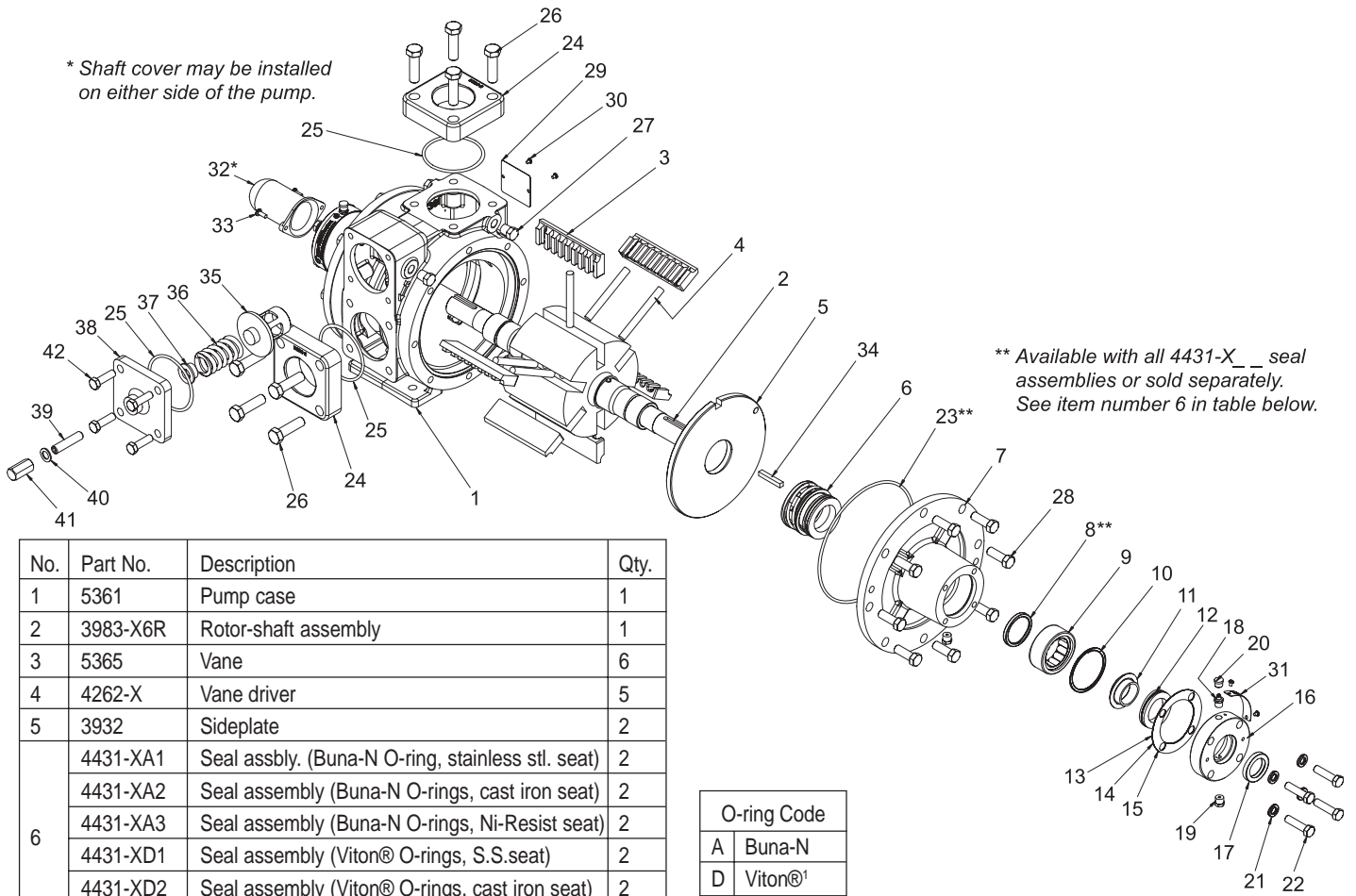

No.	Part No.	Description	Qty.
1	5361	Pump case	1
2	3983-X6R	Rotor-shaft assembly	1
3	5365	Vane	6
4	4262-X	Vane driver	5
5	3932	Sideplate	2
6	4431-XA1	Seal assbly. (Buna-N O-ring, stainless stl. seat)	2
	4431-XA2	Seal assembly (Buna-N O-rings, cast iron seat)	2
	4431-XA3	Seal assembly (Buna-N O-rings, Ni-Resist seat)	2
	4431-XD1	Seal assembly (Viton® O-rings, S.S.seat)	2
	4431-XD2	Seal assembly (Viton® O-rings, cast iron seat)	2
6	4431-XD3	Seal assembly (Viton® O-rings, Ni-Resist seat)	2
	4416	Head	2
8	4438 ²	Grease seal/oil seat	2
9	2754-X	Roller bearing	2
10	2760-244	Retainer ring	2
11	4435	Thrust bearing mounting ring	2
12	4432	Thrust bearing assembly	2
13	4439-2	Bearing cap shim (0.020")	2
14	4439-1	Bearing cap shim (0.010")	2
15	4439	Bearing cap shim (0.002")	8
16	4417	Bearing cap	2
17	4441	Grease seal	2
18	2158	Grease zerk	2
19	1343	Grease relief fitting	4
20	2159	Lubricap	2
21	7206-037A	Lock washer (3/8")	8
22	7001-037 NC150A	Hex head bolt	8
23	2-260 ^{2,3}	O-ring	2
24	5363-2	Flange (2" NPT)	2
	5363-2.5	Flange (2-1/2" NPT)	2
	5367-2	Flange (2" BSPT)	2
	5367-2.5	Flange (2-1/2" BSPT)	2
	5363-2S	Flange (2" Weld)	2
	5363-2.5S	Flange (2-1/2" Weld)	2

No.	Part Number	Description	Qty.
25	2-234 ³	O-ring	3
26	7001-050NC175A	Hex head bolt	8
27	3442	Pipe plug (1/4" NPT)	5
28	7001-043NC125A	Hex head bolt	16
29	2397	Name plate	1
30	7012-006SF019E	Pan head Phillip (6-32 x 3/16")	6
31	1359	Lubrication plate	2
32	4985	Shaft cover	1
33	7012-010SF050E	Pan head Phillip (10-24 x 1/2")	2
34	2270	Shaft key	1
35	5373	Bypass valve	1
36	5481	Bypass valve spring (50–75 psi)	1
	5360	Bypass valve spring (75–100 psi)	1
	5482	Bypass valve spring (100–125 psi)	1
37	5364	Bypass valve spring guide	1
38	5409	Bypass valve cap	1
39	7006-043NC200A	Adjustment set screw	1
40	1480	Gasket	1
41	2458	Adjustment set screw cap	1
42	7001-037NC075A	Hex head bolt	4

¹ Registered trademark of the DuPont company.

² Available with all 4431-X__ seal assemblies or sold separately.

³ _ denotes O-ring code listed above.

Appendix E—Part Details for the PZ7 Air Operated Valve (AOV)

5470-X Air Operated Valve (AOV) Assembly for a PZ7

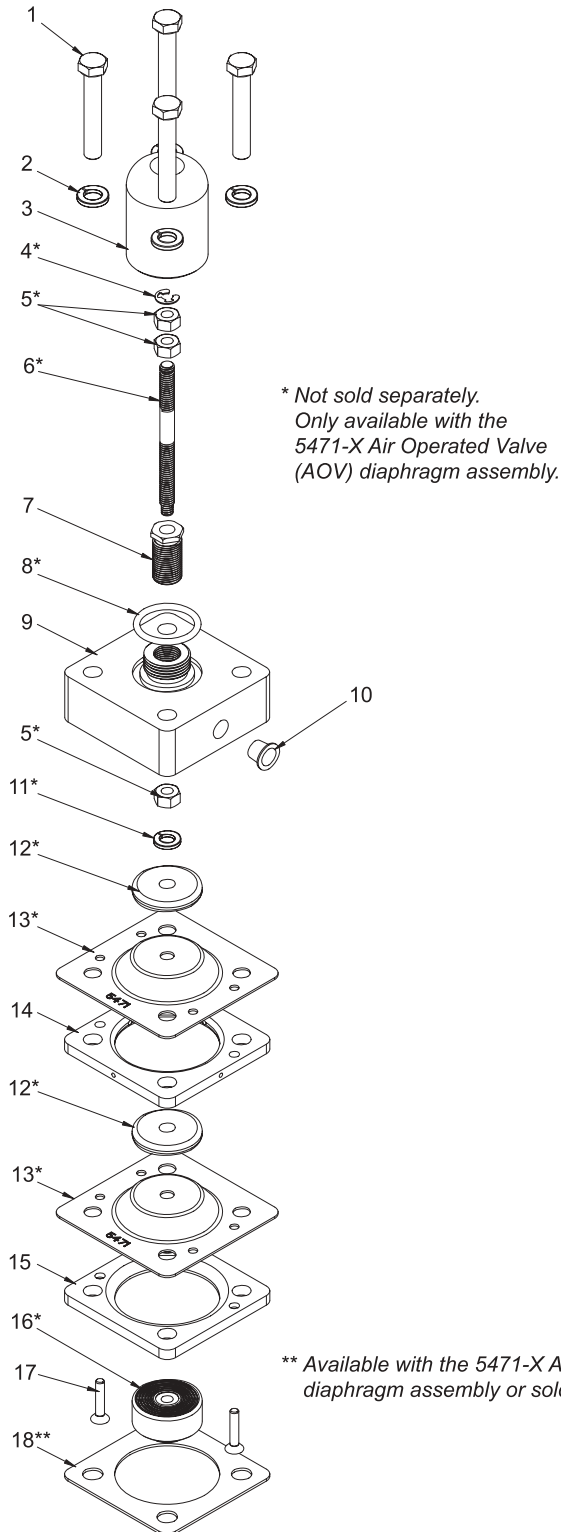

No.	Part Number	Description	Qty.
1	7001-037NC225A	Hex head bolt	4
2	7206-037A	Lock washer 0.375"	4
3	5457	AOV adjustment stem cap	1
4	5471-X ¹	AOV adjustment stem retainer ring	1
5	5471-X ¹	Hex nut	3
6	5471-X ¹	Air operated valve adjustment stem	1
7	5459	AOV low flow adjustment bushing	1
8	5471-X ¹	O-ring	1
9	5470	Air operated valve housing	1
10	2854	Threaded pipe plug	1
11	5471-X ¹	Lock washer 0.3125"	1
12	5471-X ¹	Air operated valve disc	2
13	5471-X ¹	Air operated valve diaphragm	2
14	5464	Air operated valve intermediate plate	1
15	5465	Air operated valve diaphragm cover	1
16	5471-X ¹	Diaphragm valve disc	1
17	5460	#10-24 x 1 flat head cap screw	2
18	5472 ²	Air operated valve gasket	1

¹ Not sold separately. Only available with the 5471-X Air Operated Valve (AOV) diaphragm assembly.

² Available with the 5471-X AOV diaphragm assembly or sold separately.

Appendix E—Part Details for the PZ10 Air Operated Valve (AOV)

5462-X Air Operated Valve (AOV) Assembly for a PZ10

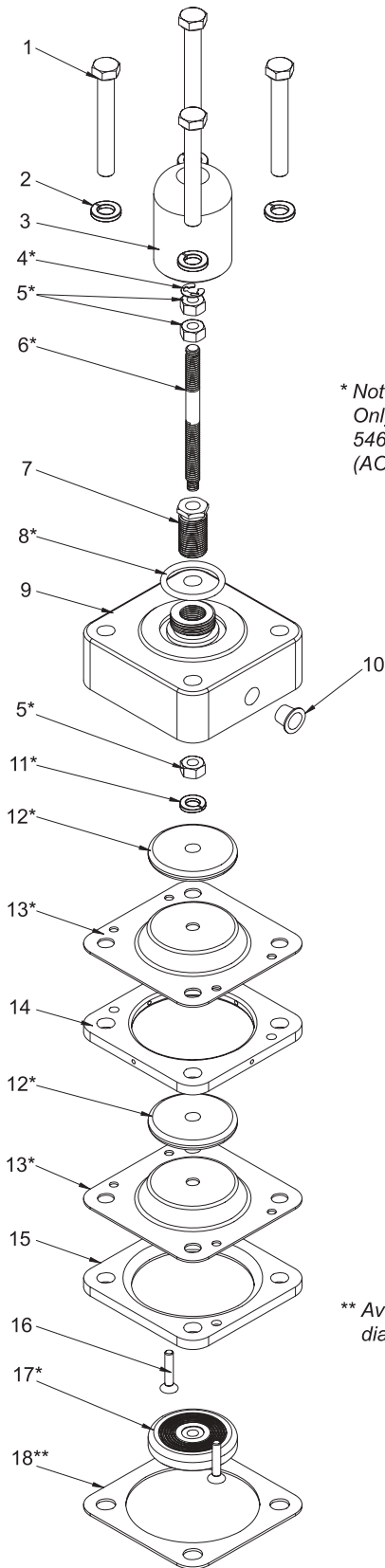

* Not sold separately.
Only available with the
5466-X Air Operated Valve
(AOV) diaphragm assembly.

** Available with the 5466-X AOV
diaphragm assembly or sold separately.

No.	Part Number	Description	Qty.
1	7001-037NC275A	Hex head bolt	4
2	7206-037A	Lock washer 0.375"	4
3	5457	AOV adjustment stem cap	1
4	5466-X ¹	AOV adjustment stem retainer ring	1
5	5466-X ¹	Hex nut	3
6	5466-X ¹	Air operated valve adjustment stem	1
7	5459	AOV low flow adjustment bushing	1
8	5466-X ¹	O-ring	1
9	5462	Air operated valve housing	1
10	2854	Threaded pipe plug	1
11	5466-X ¹	Lock washer 0.3125"	1
12	5466-X ¹	Air operated valve disc	2
13	5466-X ¹	Air operated valve diaphragm	2
14	5461	Air operated valve intermediate plate	1
15	5463	Air operated valve diaphragm cover	1
16	5460	#10-24 x 1 flat head cap screw	2
17	5466-X ¹	Diaphragm valve disc	1
18	5467 ²	Air operated valve gasket	1

¹ Not sold separately. Only available with the 5466-X Air Operated Valve (AOV) diaphragm assembly.

² Available with the 5466-X AOV diaphragm assembly or sold separately.

Appendix E—Part Details for Strainer

5422-X_1 Strainer Assembly for a PZ7 and PZ10

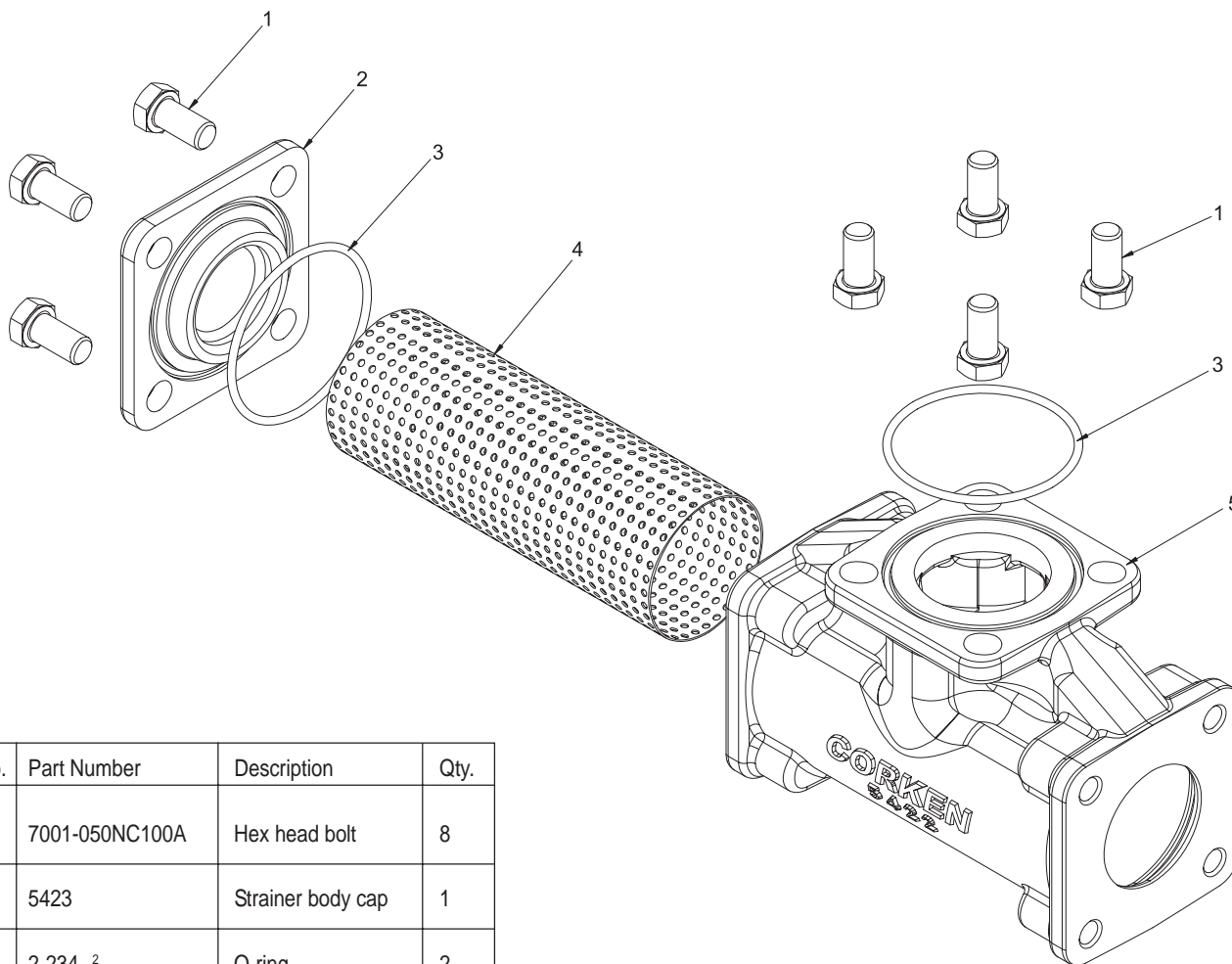

No.	Part Number	Description	Qty.
1	7001-050NC100A	Hex head bolt	8
2	5423	Strainer body cap	1
3	2-234_2	O-ring	2
4	5433	Strainer basket	1
5	5422	Strainer body	1

O-ring Code	
A	Buna-N
D	Viton® ³

¹ _ denotes O-ring code listed above. 5422-XA for Buna-N or 5422-XD for Viton®.

² _ denotes O-ring code listed above. 2-234A for Buna-N or 2-234D for Viton®.

³Registered trademark of the DuPont company.

Appendix F—Trouble Shooting Guide for the PZ-Series Pump

In diagnosing pump and system troubles, record the following data during product transfers:

1. Pressure at pump suction.
2. Pressure at pump discharge.
3. Pipe size and length of suction and discharge lines.
4. Pump speed if practical.

Problem	Cause	Solution
Low capacity	Pump speed too slow	Check engine speed and PTO ratio. Consult pump performance curve. Use tachometer on pump if speed is questionable.
	High differential pressure	Restriction in discharge piping or hose too small. Pump speed too high.
	Clogged strainer	Clean strainer.
	Suction pipe too small or restricted	Indicated by pump inlet pressure dropping several pounds when pump is started. Remove restriction or modify piping.
	Worn vanes	Replace.
	Worn sideplates	Reverse or replace sideplates. Check universal drive assembly to make sure angularity is within limits, yokes are parallel and slip-joint is greased. Check bearings.
	Vanes sticking	Remove vanes and clean out foreign material (check strainer). Replace vanes if swollen.
Pump runs but no flow	Valve closed	Check valves. Make sure tank valve is open! Refer to manufacturer's instructions.
	Broken shaft	Disassemble and inspect pump. Repair if necessary.
	Defective meter	Service meter.
Pump will not turn—locked up	Foreign matter in pump	Clean out the pump—check strainer in suction line.
	Vanes broken	Clean out pump carefully and replace vanes. Has pump been operated dry? Then, check for damage to cam and rotor shaft assembly.
	Bearing seized	Replace pump bearings. Grease monthly. Use ball bearing grease manufactured for intended service.
	Moisture frozen in pump	Let thaw and break loose carefully.
Will not build pressure	Poor suction conditions	Clean inlet strainer. Increase pipe size.
	Internal bypass valve set too low or stuck open	Check valve or set valve for higher pressure (see instructions).
	Worn vanes and/or sideplates	Disassemble, inspect and repair as necessary. Has pump been run dry? If so check for damage to vanes & rotor-shaft assembly.
Pump is noisy	Cavitation from poor suction conditions	Clean inlet strainer. Increase pipe size.
	Vanes sticking	Remove vanes and clean out foreign material (check strainer). Replace vanes if swollen.
	Bearings worn	Replace if necessary—grease monthly.
	Very high differential pressure	Check for restriction in discharge line. Delivery hose too small and too long? Slow down pump!
		Check vapor release float assembly on meter air eliminator and meter differential valve.
PTO shaft vibration	Inspect and repair driveline component.	
Pump leaks around shaft	Seal or O-rings failed	Inspect seal assembly and replace if necessary. Keep new seal very clean when replacing seal. Recommend a light oil film on O-rings. Has pump been run dry? If so check for damage to vanes & rotor-shaft assembly.

Appendix G—Flush and Storage Instructions for the PZ-Series Pump

If the PZ-Series pump is to be removed from service for some time, the pump must be protected. Piping and tanks not in service should also be protected, as the rust particles can destroy the pump's seals almost immediately after start-up.

1. Fill or thoroughly flush the pump with a light rust inhibiting oil. If the pump is flushed with oil, place some desiccant packets inside the pump for added protection.
2. Plug all pump openings.
3. Store in a dry location.
4. Before placing the pump back into service, drain the oil and remove any desiccant packets.
5. Refer to the Operation of the PZ-Series Truck Pump on page 5 of this Installation, Operation & Maintenance (IOM) manual.



Corken, Inc. • A Unit of IDEX Corporation

P.O. Box 12338, Oklahoma City, OK 73157 U.S.A.

Phone (405) 946-5576 or 1-800-631-4929

Fax (405) 948-7343

Visit our website at <http://www.corken.com>

E-mail us at info.corken@idexcorp.com